

Coaxial

# Voltage Controlled Oscillator

## ZX95-310+

Linear Tuning 240 to 305 MHz

### Features

- Low phase noise
- Low pulling
- Low pushing
- Protected by US patent 6,790,049

### Applications

- R&D
- LAB
- Instrumentation
- Wireless communications
- Cable TV



CASE STYLE: GB956

Connectors	Model	Price	Qty.
SMA	ZX95-310-S+	\$ 40.95 ea.	(1-9)

**+ RoHS compliant in accordance with EU Directive (2002/95/EC)**

*The +Suffix has been added in order to identify RoHS Compliance. See our web site for RoHS Compliance methodologies and qualifications.*

### Electrical Specifications

MODEL NO.	FREQ. (MHz)		POWER OUTPUT (dBm)	PHASE NOISE dBc/Hz SSB at offset frequencies, kHz				TUNING					NON HARMONIC SPURIOUS (dBc)	HARMONICS (dBc)		PULLING pk-pk @ 12 dB (MHz)	PUSHING (MHz/V)	DC OPERATING POWER	
	Min.	Max.		Typ.	1	10	100	1000	VOLTAGE RANGE (V)	SENSITIVITY (MHz/V)	PORT CAP (pF)	3 dB MODULATION BANDWIDTH (MHz)		Typ.	Typ.			Max.	Typ.
ZX95-310+	240	305	+6	-89	-112	-133	-153	0.5	17	5 - 7	80	40	-90	-24	-14	0.5	0.7	5	30

### Maximum Ratings

Operating Temperature	-55°C to 85°C
Storage Temperature	-55°C to 100°C
Absolute Max. Supply Voltage (Vcc)	7V
Absolute Max. Tuning Voltage (Vtune)	19V
All specifications	50 ohm system

Permanent damage may occur if any of these limits are exceeded.

### Outline Drawing

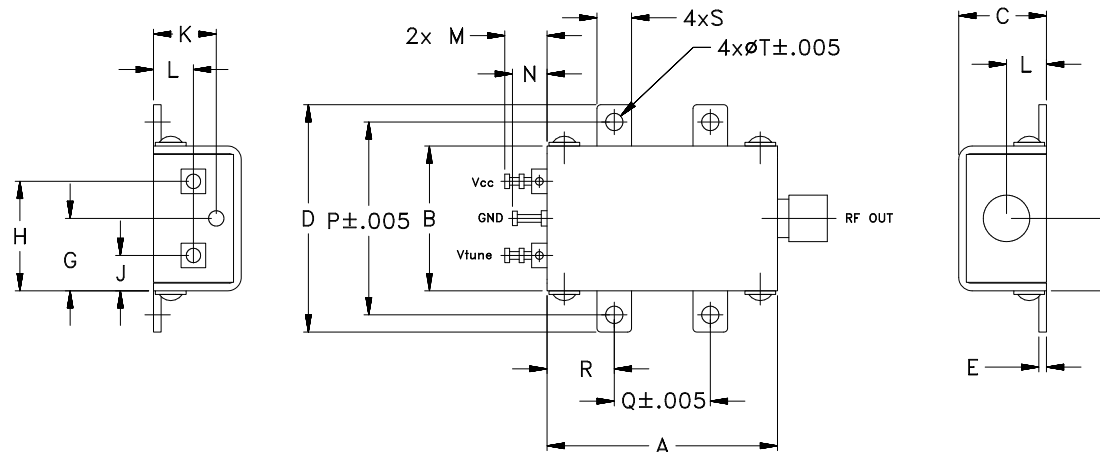

### Outline Dimensions (inch/mm)

A	B	C	D	E	F	G	H	J	K	L	M	N	P	Q	R	S	T	WT.
1.20	.75	.46	1.18	.04	.38	.45	.57	.18	.33	.21	.22	.18	1.00	.50	.35	.18	.106	GRAM
30.48	19.05	11.68	29.97	1.02	9.65	11.43	14.48	4.57	8.38	5.33	5.59	4.57	25.40	12.70	8.89	4.57	2.69	35.0

**Mini-Circuits®**

ISO 9001 ISO 14001 AS 9100 CERTIFIED

P.O. Box 350166, Brooklyn, New York 11235-0003 (718) 934-4500 Fax (718) 332-4661 The Design Engineers Search Engine Provides ACTUAL Data Instantly at [minicircuits.com](http://minicircuits.com)

RF/IRF MICROWAVE COMPONENTS

For detailed performance specs & shopping online see web site

**Notes:** 1. Performance and quality attributes and conditions not expressly stated in this specification sheet are intended to be excluded and do not form a part of this specification sheet. 2. Electrical specifications and performance data contained herein are based on Mini-Circuit's applicable established test performance criteria and measurement instructions. 3. The parts covered by this specification sheet are subject to Mini-Circuits standard limited warranty and terms and conditions (collectively, "Standard Terms"); Purchasers of this part are entitled to the rights and benefits contained therein. For a full statement of the Standard Terms and the exclusive rights and remedies thereunder, please visit Mini-Circuits' website at [www.minicircuits.com/MCLStore/terms.jsp](http://www.minicircuits.com/MCLStore/terms.jsp).

REV. OR  
M120937  
EDR-8302F2  
ZX95-310+  
RAV  
090902  
Page 1 of 2

# Performance Data & Curves\*

# ZX95-310+

V TUNE	TUNE SENS (MHz/V)	FREQUENCY (MHz)			POWER OUTPUT (dBm)			Icc (mA)	HARMONICS (dBc)			FREQ. PUSH (MHz/V)	FREQ. PULL (MHz)	PHASE NOISE (dBc/Hz) at offsets				FREQ OFFSET (KHz)	PHASE NOISE at 273 MHz (dBc/Hz)
		-55°C	+25°C	+85°C	-55°C	+25°C	+85°C		F2	F3	F4			1kHz	10kHz	100kHz	1MHz		
0.00	7.39	226.3	225.6	224.9	6.33	6.15	5.89	23.49	-18.2	-26.3	-32.2	0.05	0.15	-90.9	-113.5	-133.9	-153.8	1.0	-89.86
0.50	7.22	230.0	229.3	228.6	5.95	5.81	5.62	23.82	-18.4	-25.2	-31.8	0.65	0.36	-92.0	-114.3	-135.1	-155.1	2.0	-97.50
1.00	6.15	233.6	232.9	232.2	5.90	5.77	5.58	23.84	-18.9	-25.3	-31.6	0.59	0.37	-91.5	-114.7	-135.0	-155.1	3.5	-102.82
2.00	5.44	239.5	238.8	238.1	5.85	5.71	5.52	23.91	-20.0	-25.4	-32.3	0.43	0.42	-92.2	-115.4	-136.2	-156.2	6.0	-108.50
3.00	5.24	244.9	244.2	243.4	5.81	5.67	5.49	24.02	-21.0	-25.5	-33.2	0.35	0.44	-91.8	-115.1	-136.1	-156.1	8.5	-111.97
4.00	5.31	250.3	249.4	248.5	5.78	5.65	5.47	24.07	-21.7	-25.6	-33.5	0.32	0.45	-89.8	-114.0	-134.4	-154.5	10.0	-113.35
4.90	5.57	255.3	254.2	253.3	5.78	5.65	5.45	24.04	-22.3	-25.7	-33.6	0.30	0.47	-88.2	-112.5	-133.2	-153.1	20.8	-120.09
6.00	6.03	261.7	260.5	259.6	5.81	5.65	5.44	23.96	-23.0	-25.9	-33.9	0.33	0.48	-89.2	-112.2	-133.0	-152.9	35.5	-124.87
7.00	6.42	267.8	266.6	265.7	5.87	5.64	5.43	23.89	-23.8	-26.1	-34.5	0.44	0.38	-89.6	-113.4	-134.0	-153.9	60.7	-129.30
8.00	6.60	274.1	273.1	272.2	5.95	5.62	5.42	23.85	-24.5	-26.7	-35.1	0.61	0.18	-89.4	-113.4	-134.1	-153.9	86.7	-132.62
9.00	6.51	280.5	279.7	278.7	6.03	5.62	5.42	23.85	-24.9	-27.0	-35.4	0.81	0.03	-89.4	-112.1	-133.1	-153.1	100.0	-133.95
10.00	6.18	287.1	286.1	285.0	6.07	5.64	5.41	23.89	-25.1	-27.3	-35.3	1.01	0.22	-87.3	-110.7	-131.6	-151.6	148.1	-137.27
11.00	5.62	293.4	292.2	291.0	6.13	5.67	5.40	23.97	-25.1	-27.5	-34.9	1.15	0.42	-86.9	-110.0	-130.7	-150.6	177.0	-138.84
12.00	5.17	299.0	297.7	296.5	6.20	5.71	5.40	24.07	-25.1	-27.7	-34.5	1.27	0.58	-85.5	-109.3	-130.0	-150.0	211.6	-140.45
13.00	4.78	304.0	302.7	301.6	6.25	5.74	5.39	24.19	-25.2	-28.0	-34.4	1.36	0.69	-85.5	-108.9	-129.6	-149.5	302.4	-143.59
14.00	4.32	308.7	307.4	306.2	6.30	5.75	5.38	24.30	-25.7	-28.3	-34.4	1.33	0.74	-84.9	-108.1	-128.9	-148.9	361.5	-145.13
15.00	3.87	312.9	311.6	310.2	6.33	5.76	5.37	24.40	-25.7	-28.7	-34.3	1.24	0.76	-83.4	-106.9	-128.1	-148.0	507.5	-148.08
16.00	3.47	316.8	315.4	313.9	6.32	5.75	5.37	24.48	-25.7	-29.2	-34.0	1.13	0.77	-83.1	-106.7	-127.4	-147.3	606.7	-149.64
16.50	3.29	318.7	317.1	315.6	6.32	5.75	5.36	24.51	-25.7	-29.4	-34.0	1.09	0.77	-82.8	-106.2	-127.1	-147.1	851.6	-152.62
17.00	3.13	320.4	318.8	317.2	6.31	5.75	5.36	24.54	-25.7	-29.7	-34.0	1.04	0.76	-82.1	-105.9	-126.7	-146.8	1000.0	-153.76

\*at 25°C unless mentioned otherwise

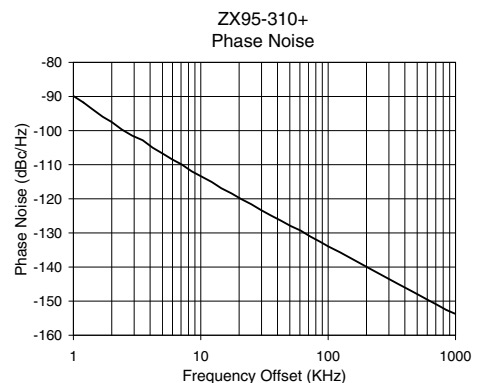
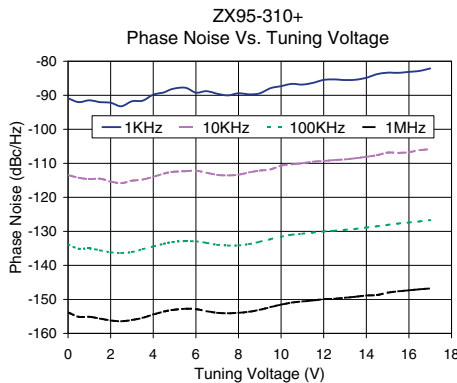
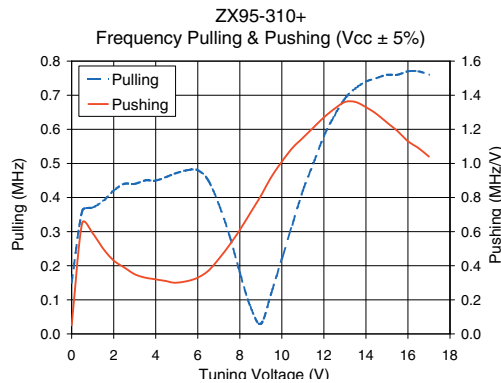
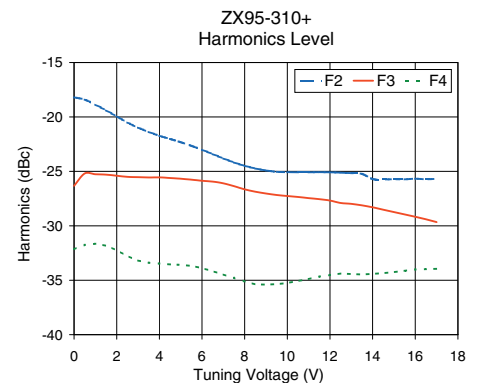
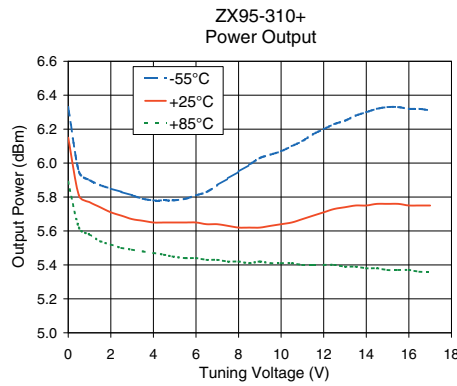
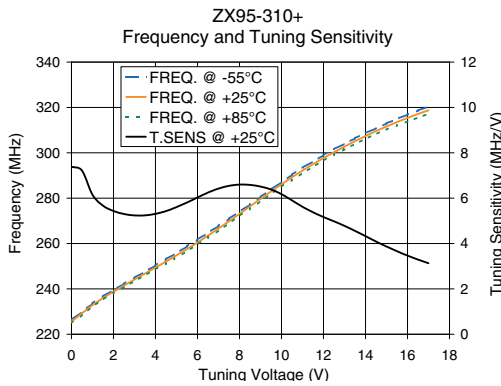

For detailed performance specs & shopping online see web site

P.O. Box 350166, Brooklyn, New York 11235-0003 (718) 934-4500 Fax (718) 332-4661 The Design Engineers Search Engine Provides ACTUAL Data Instantly at [minicircuits.com](http://minicircuits.com)

IF/RF MICROWAVE COMPONENTS

Notes: 1. Performance and quality attributes and conditions not expressly stated in this specification sheet are intended to be excluded and do not form a part of this specification sheet. 2. Electrical specifications and performance data contained herein are based on Mini-Circuit's applicable established test performance criteria and measurement instructions. 3. The parts covered by this specification sheet are subject to Mini-Circuits standard limited warranty and terms and conditions (collectively, "Standard Terms"); Purchasers of this part are entitled to the rights and benefits contained therein. For a full statement of the Standard Terms and the exclusive rights and remedies thereunder, please visit Mini-Circuits' website at [www.minicircuits.com/MCLStore/terms.jsp](http://www.minicircuits.com/MCLStore/terms.jsp).