

Coaxial

# Voltage Controlled Oscillator

## ZX95-2490C+

Linear Tuning 2020 to 2490 MHz

### Features

- Linear tuning characteristics
- Low phase noise
- Low pushing
- Low pulling
- Protected by US patent 6,790,049



CASE STYLE: GB956

### Applications

- R&D
- LAB
- Instrumentation
- Wireless communications
- Wire-line broadband access

Connectors	Model	Price	Qty.
SMA	ZX95-2490C-S+	\$ 40.95 ea.	(1-9)

**+ RoHS compliant in accordance with EU Directive (2002/95/EC)**

*The +Suffix has been added in order to identify RoHS Compliance. See our web site for RoHS Compliance methodologies and qualifications.*

### Electrical Specifications

MODEL NO.	FREQ. (MHz)		POWER OUTPUT (dBm)	PHASE NOISE dBc/Hz SSB at offset frequencies, kHz				TUNING				NON HARMONIC SPURIOUS (dBc)	HARMONICS (dBc)		PULLING pk-pk @ 12 dB (MHz)	PUSHING (MHz/V)	DC OPERATING POWER			
	Min.	Max.		Typ.	1	10	100	1000	VOLTAGE RANGE (V)	SENSITIVITY (MHz/V)	PORT CAP (pF)		3 dB MODULATION BANDWIDTH (MHz)	Typ.			Typ.	Max.	Typ.	Typ.
ZX95-2490C+	2020	2490	+7.2	-79	-107	-128	-149	0.25	16	30	-40	30	45	-90	-32	-15	2.5	0.4	8	40

### Maximum Ratings

Operating Temperature	-55°C to 85°C
Storage Temperature	-55°C to 100°C
Absolute Max. Supply Voltage (Vcc)	10V
Absolute Max. Tuning Voltage (Vtune)	18V
All specifications	50 ohm system

Permanent damage may occur if any of these limits are exceeded.

### Outline Drawing

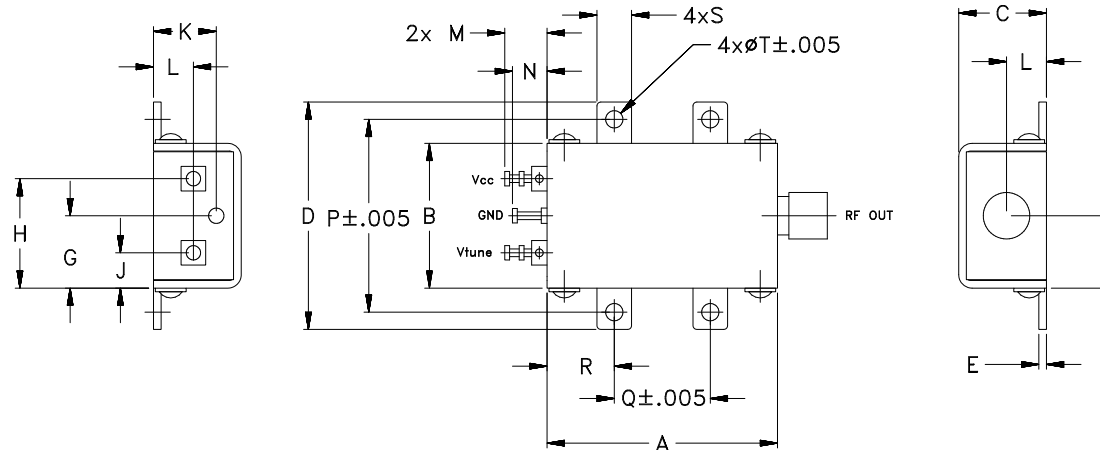

### Outline Dimensions (inch/mm)

A	B	C	D	E	F	G	H	J	K	L	M	N	P	Q	R	S	T	WT.
1.20	.75	.46	1.18	.04	.38	.45	.57	.18	.33	.21	.22	.18	1.00	.50	.35	.18	.106	GRAM
30.48	19.05	11.68	29.97	1.02	9.65	11.43	14.48	4.57	8.38	5.33	5.59	4.57	25.40	12.70	8.89	4.57	2.69	35.0



For detailed performance specs & shopping online see web site

P.O. Box 350166, Brooklyn, New York 11235-0003 (718) 934-4500 Fax (718) 332-4661 The Design Engineers Search Engine Provides ACTUAL Data Instantly at [minicircuits.com](http://minicircuits.com)

**Notes:** 1. Performance and quality attributes and conditions not expressly stated in this specification sheet are intended to be excluded and do not form a part of this specification sheet. 2. Electrical specifications and performance data contained herein are based on Mini-Circuit's applicable established test performance criteria and measurement instructions. 3. The parts covered by this specification sheet are subject to Mini-Circuits standard limited warranty and terms and conditions (collectively, "Standard Terms"); Purchasers of this part are entitled to the rights and benefits contained therein. For a full statement of the Standard Terms and the exclusive rights and remedies thereunder, please visit Mini-Circuits' website at [www.minicircuits.com/MCLStore/terms.jsp](http://www.minicircuits.com/MCLStore/terms.jsp).

REV. OR  
M120336  
EDR-82707F2  
ZX95-2490C+  
RAV  
090831  
Page 1 of 2

# Performance Data & Curves\*

# ZX95-2490C+

V TUNE	TUNE SENS (MHz/V)	FREQUENCY (MHz)			POWER OUTPUT (dBm)			Icc (mA)	HARMONICS (dBc)			FREQ. PUSH (MHz/V)	FREQ. PULL (MHz)	PHASE NOISE (dBc/Hz) at offsets				FREQ OFFSET (KHz)	PHASE NOISE at 2255 MHz (dBc/Hz)
		-55°C	+25°C	+85°C	-55°C	+25°C	+85°C		F2	F3	F4			1kHz	10kHz	100kHz	1MHz		
0.00	31.29	1999.8	1994.3	1990.3	7.31	7.05	6.71	32.93	-36.9	-31.3	-60.1	1.12	1.57	-82.1	-110.0	-131.2	-151.6	1.0	-78.81
0.25	30.12	2007.4	2002.2	1998.3	7.29	7.10	6.79	32.90	-37.2	-30.3	-60.3	1.05	1.53	-82.5	-110.0	-131.4	-151.6	2.0	-88.29
1.00	28.65	2029.5	2024.5	2020.7	7.19	7.09	6.82	32.75	-38.3	-29.3	-62.2	0.88	1.94	-80.6	-109.7	-131.2	-151.1	3.5	-95.57
2.00	30.19	2058.5	2053.4	2049.5	7.24	7.11	6.80	32.53	-34.8	-27.9	-64.7	0.82	2.49	-81.7	-108.7	-130.1	-150.5	6.0	-101.55
3.00	33.01	2089.8	2084.2	2080.1	7.37	7.28	6.97	32.30	-32.1	-26.8	-67.5	0.79	1.47	-79.4	-107.7	-129.7	-149.7	8.5	-105.54
4.00	36.15	2124.2	2118.1	2113.5	7.27	7.24	6.97	32.07	-30.2	-25.4	-69.8	0.73	2.79	-78.5	-107.2	-129.3	-149.1	10.0	-107.09
5.00	38.04	2161.1	2154.7	2149.8	7.27	7.14	6.77	31.91	-29.5	-24.8	-75.5	0.64	1.65	-79.2	-107.1	-129.2	-149.3	20.8	-114.46
6.00	39.84	2200.3	2193.3	2187.9	7.36	7.22	6.79	31.78	-29.4	-26.2	-66.2	0.52	2.82	-80.6	-107.2	-129.0	-149.3	35.5	-119.46
7.00	40.53	2240.9	2233.4	2227.6	7.28	7.14	6.68	31.67	-31.1	-28.7	-67.0	0.37	1.96	-79.0	-107.0	-128.8	-148.8	60.7	-123.68
7.50	40.09	2261.3	2253.7	2247.7	7.29	7.06	6.55	31.65	-31.8	-29.6	-62.4	0.30	3.00	-79.9	-107.1	-128.7	-148.8	86.7	-127.52
8.00	40.03	2281.5	2273.7	2267.6	7.41	7.16	6.58	31.63	-32.3	-31.5	-63.1	0.24	3.14	-78.6	-107.3	-129.0	-148.9	100.0	-128.74
9.00	40.15	2322.0	2313.8	2307.3	7.48	7.28	6.68	31.59	-34.3	-33.5	-51.0	0.14	3.11	-79.6	-106.9	-128.6	-148.7	148.1	-132.19
10.00	38.72	2362.2	2353.8	2347.1	7.45	7.20	6.56	31.58	-34.9	-35.9	-50.5	0.06	2.79	-78.2	-106.7	-128.4	-148.8	177.0	-133.78
11.00	37.66	2400.6	2392.0	2385.3	7.73	7.51	6.83	31.58	-35.3	-38.5	-50.2	0.01	2.96	-78.9	-106.8	-128.5	-149.0	211.6	-135.22
12.00	35.88	2438.2	2429.5	2422.4	7.65	7.45	6.82	31.57	-35.0	-40.3	-49.7	0.00	2.14	-79.6	-106.6	-128.1	-147.9	302.4	-138.17
13.00	32.57	2473.0	2464.5	2457.7	7.86	7.56	6.90	31.61	-34.8	-41.5	-51.1	0.07	3.58	-78.1	-106.9	-128.4	-148.4	361.5	-139.84
13.50	31.31	2489.3	2480.8	2474.0	7.95	7.69	7.05	31.61	-34.3	-43.0	-50.8	0.12	2.82	-79.9	-106.9	-128.4	-148.4	507.5	-142.57
14.00	29.98	2505.1	2496.5	2489.5	7.99	7.78	7.14	31.60	-33.9	-43.6	-50.4	0.18	2.40	-78.7	-106.6	-128.2	-148.1	606.7	-144.40
15.00	25.77	2534.0	2525.5	2518.6	7.96	7.75	7.15	31.61	-33.0	-43.9	-51.1	0.28	3.25	-80.9	-107.0	-128.2	-147.8	851.6	-147.31
16.00	21.04	2558.2	2550.1	2543.3	8.14	7.84	7.23	31.63	-31.6	-45.7	-50.5	0.31	2.99	-81.0	-107.2	-128.4	-148.4	1000.0	-148.44

\*at 25°C unless mentioned otherwise

