

Coaxial

# Voltage Controlled Oscillator

## ZX95-1480+

Wide Band 670 to 1480 MHz

### Features

- Low phase noise
- Low pushing
- Protected by US patent 6,790,049



CASE STYLE: GB956

### Applications

- R&D
- LAB
- Instrumentation
- Wireless communications
- Radio link

Connectors	Model	Price	Qty.
SMA	ZX95-1480-S+	\$ 49.95 ea.	(1-9)

**+ RoHS compliant in accordance with EU Directive (2002/95/EC)**

*The +Suffix has been added in order to identify RoHS Compliance. See our web site for RoHS Compliance methodologies and qualifications.*

### Electrical Specifications

MODEL NO.	FREQ. (MHz)		POWER OUTPUT (dBm)	PHASE NOISE dBc/Hz SSB at offset frequencies, kHz				TUNING					NON HARMONIC SPURIOUS (dBc)	HARMONICS (dBc)		PULLING pk-pk @12 dB (MHz)	PUSHING (MHz/V)	DC OPERATING POWER	
	Min.	Max.		Typ.	1	10	100	1000	VOLTAGE RANGE (V)	SENSITIVITY (MHz/V)	PORT CAP (pF)	3 dB MODULATION BANDWIDTH (MHz)		Typ.	Typ.			Max.	Typ.
ZX95-1480+	670	1480	+6	-66	-97	-119	-140	0.5	12.5	72-100	84	40	-90	-14	-	3.5	2.5	5	40

### Maximum Ratings

Operating Temperature	-55°C to 85°C
Storage Temperature	-55°C to 100°C
Absolute Max. Supply Voltage (Vcc)	7.0V
Absolute Max. Tuning Voltage (Vtune)	14.5V
All specifications	50 ohm system

Permanent damage may occur if any of these limits are exceeded.

### Outline Drawing

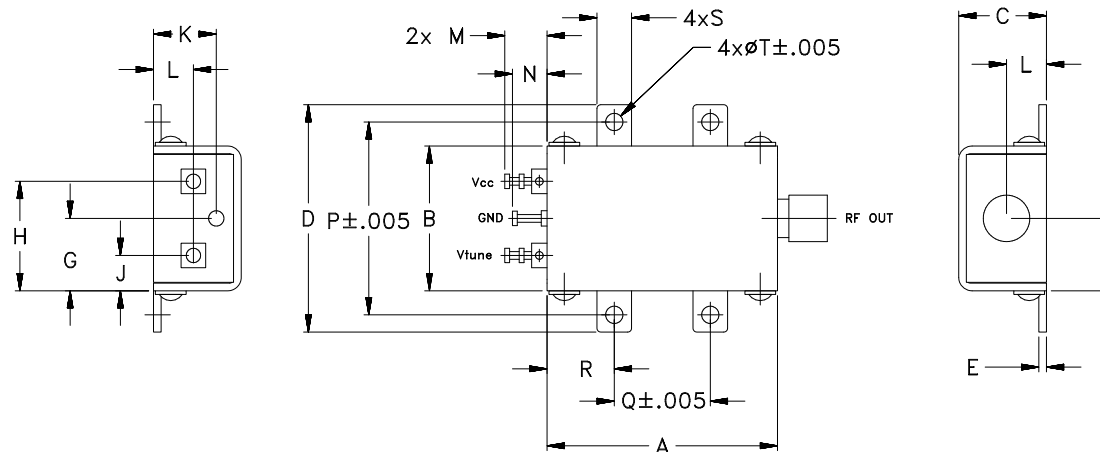

### Outline Dimensions (inch/mm)

A	B	C	D	E	F	G	H	J	K	L	M	N	P	Q	R	S	T	WT.
1.20	.75	.46	1.18	.04	.38	.45	.57	.18	.33	.21	.22	.18	1.00	.50	.35	.18	.106	GRAM
30.48	19.05	11.68	29.97	1.02	9.65	11.43	14.48	4.57	8.38	5.33	5.59	4.57	25.40	12.70	8.89	4.57	2.69	35.0



For detailed performance specs & shopping online see web site

P.O. Box 350166, Brooklyn, New York 11235-0003 (718) 934-4500 Fax (718) 332-4661 The Design Engineers Search Engine Provides ACTUAL Data Instantly at [minicircuits.com](http://minicircuits.com)

**Notes:** 1. Performance and quality attributes and conditions not expressly stated in this specification sheet are intended to be excluded and do not form a part of this specification sheet. 2. Electrical specifications and performance data contained herein are based on Mini-Circuit's applicable established test performance criteria and measurement instructions. 3. The parts covered by this specification sheet are subject to Mini-Circuits standard limited warranty and terms and conditions (collectively, "Standard Terms"); Purchasers of this part are entitled to the rights and benefits contained therein. For a full statement of the Standard Terms and the exclusive rights and remedies thereunder, please visit Mini-Circuits' website at [www.minicircuits.com/MCLStore/terms.jsp](http://www.minicircuits.com/MCLStore/terms.jsp).

REV. OR  
M120402  
EDR-8024F3  
ZX95-1480+  
RAV  
090830  
Page 1 of 2

# Performance Data & Curves\*

# ZX95-1480+

V TUNE	TUNE SENS (MHz/V)	FREQUENCY (MHz)			POWER OUTPUT (dBm)			Icc (mA)	HARMONICS (dBc)			FREQ. PUSH (MHz/V)	FREQ. PULL (MHz)	PHASE NOISE (dBc/Hz) at offsets				FREQ OFFSET (KHz)	PHASE NOISE at 1075 MHz (dBc/Hz)
		-55°C	+25°C	+85°C	-55°C	+25°C	+85°C		F2	F3	F4			1kHz	10kHz	100kHz	1MHz		
0.00	117.97	579.3	564.3	548.9	4.54	5.24	3.84	30.92	-16.5	-19.8	-25.9	1.53	2.30	-68.2	-95.4	-117.0	-137.1	1.0	-63.65
0.50	97.12	638.9	623.3	605.9	4.91	5.70	5.38	31.32	-15.9	-17.0	-23.5	1.44	2.20	-68.4	-97.8	-119.2	-139.3	2.0	-72.14
1.00	86.86	688.4	671.9	653.2	5.31	5.98	5.63	31.60	-16.1	-15.6	-22.8	1.39	2.27	-68.7	-98.0	-120.0	-140.2	3.5	-80.83
2.00	79.85	774.9	756.1	735.2	5.88	6.40	5.98	32.00	-17.2	-14.1	-23.9	1.30	2.79	-67.4	-97.6	-120.1	-140.2	6.0	-88.18
3.00	80.37	859.2	836.4	812.7	6.39	6.73	6.19	32.27	-17.6	-13.6	-25.9	1.26	3.57	-66.8	-96.2	-119.2	-139.4	8.5	-92.60
4.00	80.30	943.7	916.6	891.0	6.78	6.86	6.27	32.65	-16.7	-13.5	-28.5	1.09	3.90	-64.4	-94.9	-118.5	-138.7	10.0	-94.60
4.50	81.28	985.4	956.8	931.0	6.82	6.77	6.35	32.75	-15.9	-13.7	-30.4	1.08	3.57	-64.9	-94.3	-117.8	-137.9	20.8	-101.50
5.00	82.66	1027.2	997.4	972.1	6.96	6.79	6.24	32.79	-15.3	-14.4	-32.4	1.11	4.23	-64.9	-94.2	-117.3	-137.4	35.5	-108.14
5.50	83.65	1069.1	1038.8	1013.9	6.82	6.70	6.20	32.74	-14.6	-15.5	-30.5	1.24	3.78	-63.4	-94.8	-117.7	-137.8	60.7	-113.39
6.00	84.35	1110.9	1080.6	1057.1	6.93	6.50	6.08	32.62	-13.8	-16.7	-27.4	1.46	3.91	-65.0	-94.3	-117.7	-137.9	86.7	-116.43
6.50	85.09	1152.4	1122.8	1100.6	6.78	6.51	5.91	32.45	-13.5	-18.1	-25.4	1.81	4.43	-63.0	-94.8	-118.0	-138.1	100.0	-117.77
7.00	84.14	1193.4	1165.3	1144.5	6.68	6.31	5.75	32.26	-13.0	-19.6	-23.2	2.25	1.98	-62.8	-94.6	-118.3	-138.5	148.1	-121.21
8.00	82.38	1274.1	1249.5	1231.7	6.37	5.89	5.31	31.81	-12.0	-23.6	-21.4	3.20	1.76	-65.7	-96.7	-119.7	-139.9	177.0	-122.76
8.50	81.69	1313.9	1290.7	1274.4	6.15	5.80	5.00	31.59	-11.7	-26.4	-20.9	3.64	5.04	-66.5	-97.8	-120.4	-140.4	211.6	-124.37
9.00	79.84	1353.0	1331.5	1316.6	6.06	5.53	4.80	31.40	-11.4	-29.3	-20.8	3.98	1.85	-64.6	-98.5	-121.0	-141.1	302.4	-127.49
9.50	78.08	1391.6	1371.4	1357.9	5.90	5.40	4.52	31.23	-11.0	-31.0	-20.8	4.31	4.54	-66.9	-100.0	-121.7	-142.0	355.1	-128.81
10.00	76.42	1429.2	1410.5	1398.3	5.76	5.16	4.27	31.07	-10.7	-29.7	-20.9	4.53	2.44	-67.2	-99.5	-121.8	-142.1	498.5	-131.85
11.00	71.74	1502.2	1485.7	1475.8	5.27	4.58	3.64	30.83	-10.1	-25.5	-21.1	4.78	2.81	-68.3	-99.8	-122.6	-142.7	595.9	-133.42
12.00	67.05	1571.7	1556.5	1548.7	5.05	4.25	3.07	30.67	-9.9	-22.8	-22.6	4.70	2.48	-69.8	-100.6	-122.4	-142.8	982.3	-137.65
12.50	65.91	1604.4	1590.1	1582.9	4.78	4.02	2.80	30.61	-10.2	-21.5	-23.0	4.62	4.49	-69.3	-100.2	-122.4	-142.8	1000.0	-137.81

\*at 25°C unless mentioned otherwise

