

SPDT RF SWITCH

50Ω DC-3000 MHz

Absorptive RF Switch with internal driver.
Single Supply Voltage

Product Features

- Low Insertion loss over entire frequency range
- Super High Isolation over entire frequency range
- High Input IP3, +55 dBm typ.
- Single positive supply voltage, +2.7V to +5V
- Unique design-simultaneous switch off of RF1&RF2
- Rigid unibody case

Typical Applications

- Lab
- Instrumentation
- Test equipment



ZX80-DR230+

CASE STYLE: HL1162

Connectors	Order P/N	Price	Qty.
SMA	ZX80-DR230-S+	\$59.95 ea.	(1-9)

+ RoHS compliant in accordance with EU Directive (2002/95/EC)

The +Suffix has been added in order to identify RoHS Compliance. See our web site for RoHS Compliance methodologies and qualifications.

General Description

The ZX80-DR230+ is a 50Ω high isolation SPDT RF switch designed for wireless applications, covering a broad frequency range from DC up to 3GHz with low insertion loss. The ZX80-DR230+ operates on a single supply voltage from +2.7V to +5V. This unit includes an internal CMOS control driver with two-pins control. The ZX80-DR230+ is produced using a unique case package for ruggedness and operation in tough environments.

Functional Diagram

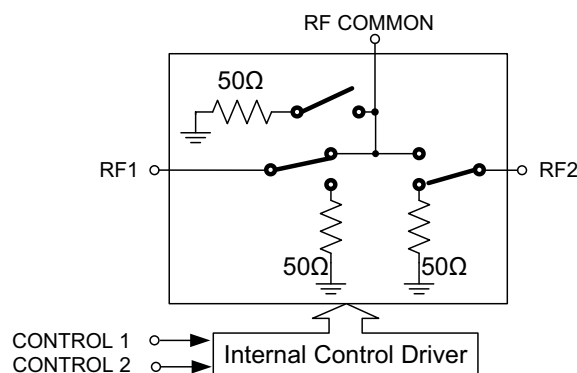

Mini-Circuits®
ISO 9001 ISO 14001 CERTIFIED

P.O. Box 350166, Brooklyn, New York 11235-0003 (718) 934-4500 Fax (718) 332-4661 For detailed performance specs & shopping online see Mini-Circuits web site



The Design Engineers Search Engine Provides ACTUAL Data Instantly From MINI-CIRCUITS At: www.minicircuits.com

RF/IF MICROWAVE COMPONENTS

ALL NEW
minicircuits.com

Rev. OR
M109521
EDR-7744
ZX80-DR230+
070225
Page 1 of 7

RF Electrical Specifications, DC-3000 MHz, T_{AMB}=25°C, V_{DD} = +3V / +5V

Parameter	Condition	Min.	Typ.	Max.	Units
Operating Frequency		DC (note 3)		3000	MHz
Insertion Loss	1 GHz		0.7	1.3	dB
	2 GHz		0.9	1.6	
	3 GHz		1.2	1.8	
Isolation between Common port and RF1/RF2 ports	1 GHz	55	64		dB
	2 GHz	46	50		
	3 GHz	35	44		
Isolation between RF1 and RF2 ports	1 GHz	60	63		dB
	2 GHz	54	60		
	3 GHz	37	48		
Return Loss @ Common port	1 GHz		20		dB
	2 GHz		17		
	3 GHz		15		
Return Loss @ RF1/RF2 ports	1 GHz		17		dB
	2 GHz		15		
	3 GHz		15		
Input IP ₂ (note 1)	5 MHz - 1000 MHz		+80		dBm
Input IP ₃ (note 1)	10 MHz - 3000MHz		+55		dBm
Input 1dB Compression (note 1,2)	1000 MHz	+28	+31		dBm

Notes:

1. Device linearity degrades below 1 MHz.
2. Note absolute maximum ratings for input power.
3. Lowest Freq. determined by value of coupling capacitors at RF ports.

DC Electrical Specifications

Parameter	Min.	Typ.	Max.	Units
V _{DD} , Supply Voltage	2.7	-	5.0	V
Supply Current (V _{DD} = 5V)	—	0.5	1.0	mA
Control Voltage Low	0	—	0.4	V
Control Voltage High	2.4	—	V _{DD}	V

Switching Specifications

Parameter	Min.	Typ.	Max.	Units
Switching Time, 50% CTRL to 90/10% RF	—	2.0	—	μSec
Video Feedthrough, 5 MHz - 1000 MHz (note 4)	—	—	15	mV _{P-P}

Note 4: Measured with a 1 nSec risetime, 0/3V pulse and 500 MHz bandwidth.

Absolute Maximum Ratings

Parameter	Ratings
Operating Temperature	-40°C to 85°C
Storage Temperature	-55°C to 100°C
V _{DD} , Supply Voltage	-0.3V Min., 6V Max.
Voltage control	-0.3V Min., 6V Max.
ESD, HBM	1000V
RF input power: (note 5)	
When the common port is connected to the RF port (RF1 or RF2)	+33dBm
When the RF port (RF1 or RF2) is not connected to the common port	+24dBm
When the common port is not connected to either RF1 or RF2	+24dBm

Note 5: See Truth Table on page 3.



P.O. Box 350166, Brooklyn, New York 11235-0003 (718) 934-4500 Fax (718) 332-4661 For detailed performance specs & shopping online see Mini-Circuits web site



The Design Engineers Search Engine Provides ACTUAL Data Instantly From MINI-CIRCUITS At: www.minicircuits.com

RF/IF MICROWAVE COMPONENTS

The RF switch control bits select the desired switch-state, as shown in **Table 1**: Truth Table.

Table 1: Truth Table.

STATE	Control Input		RF Input / Output	
	Control 1	Control 2	RF1 to RF COMMON	RF2 to RF COMMON
1	Low	Low	OFF	OFF
2	Low	High	OFF	ON
3	High	Low	ON	OFF
4	High	High	N/A	N/A

General notes:

1. When either of the RF1 or RF2 ports is closed (**ON** state), the closed port is connected to the RF Common port.
2. When either of the RF1 or RF2 ports is open (**OFF** state), the open port is connected to an internal 50Ω termination.
3. When both RF1 and RF2 ports are open (**OFF** state), the all three RF ports are connected to an internal 50Ω termination.

EXAMPLE OF STATE 3

Functional Diagram

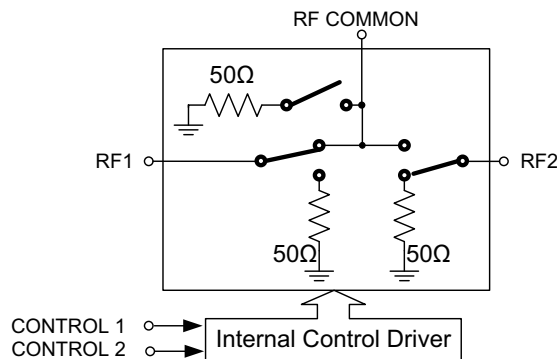

Pin Description

Function	Connection Number	Description
RF2	J1	RF I/O (note 1)
RF COM	J2	RF Common (note 1)
RF1	J3	RF I/O (note 1)
Control 1	P1	Control 1
GND	P2	Ground
Control 2	P3	Control 2
GND	P4	Ground
VDD	P5	Supply voltage

Pin Configuration

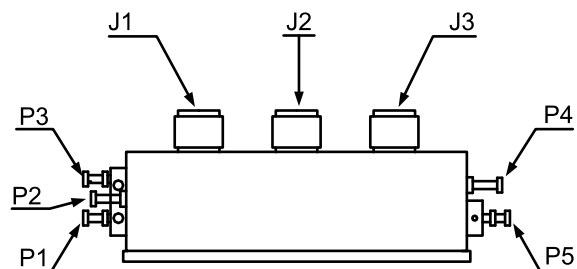

Note 1: RF ports J1, J2 and J3 must be at 0 VDC. The RF ports do not require DC blocking capacitors for proper operation if the 0 VDC requirement is met.



P.O. Box 350166, Brooklyn, New York 11235-0003 (718) 934-4500 Fax (718) 332-4661 For detailed performance specs & shopping online see Mini-Circuits web site



The Design Engineers Search Engine Provides ACTUAL Data Instantly From MINI-CIRCUITS At: www.minicircuits.com

RF/IF MICROWAVE COMPONENTS

SPDT RF SWITCH

ZX80-DR230+

Typical Performance Curves over various states. For switch state see Truth Table 1 on page 3.

INSERTION LOSS Vs. FREQUENCY @ +25°C

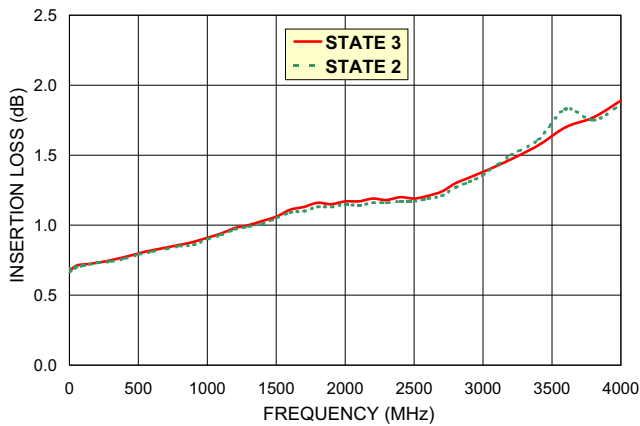

INSERTION LOSS Vs. FREQUENCY

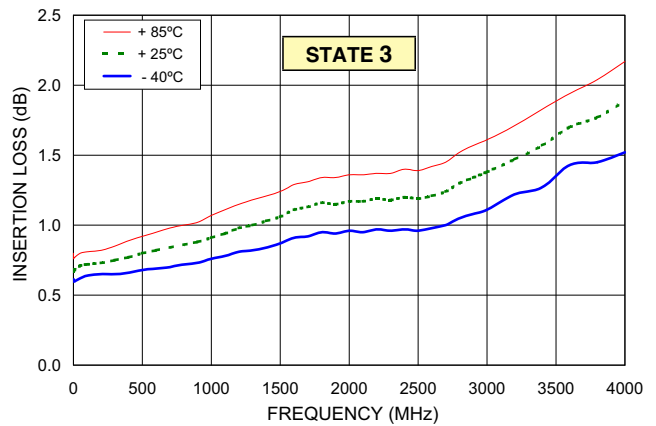

ISOLATION BETWEEN RF1 TO RF COM Vs. FREQUENCY

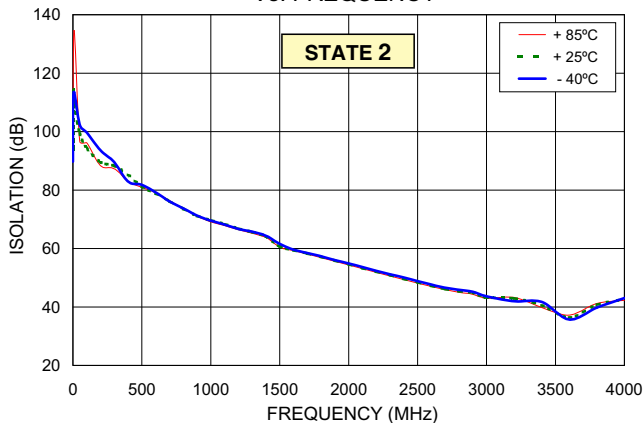

ISOLATION BETWEEN RF2 TO RF COM Vs. FREQUENCY

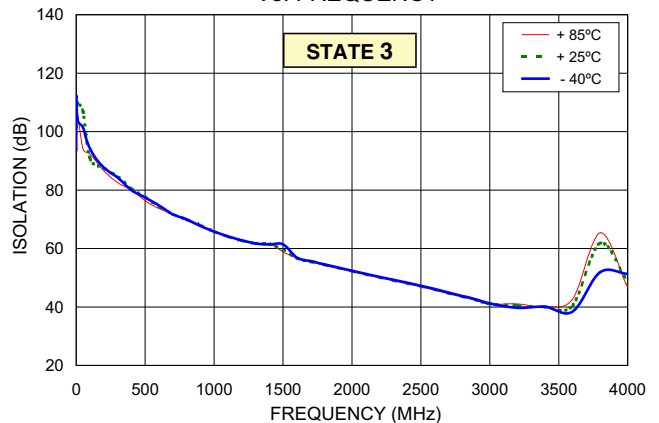

ISOLATION BETWEEN RF1 TO RF2 Vs. FREQUENCY

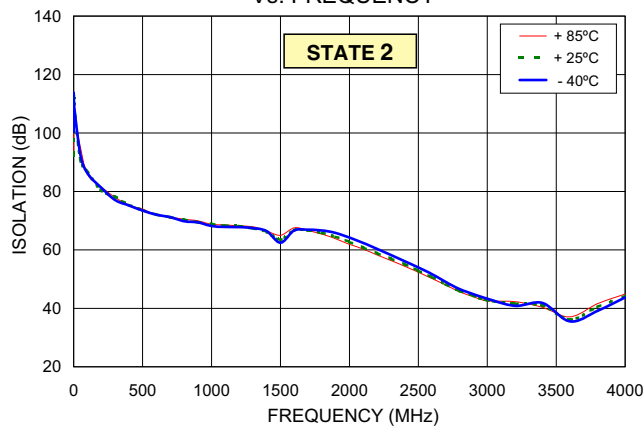

ISOLATION BETWEEN RF1 TO RF2 Vs. FREQUENCY

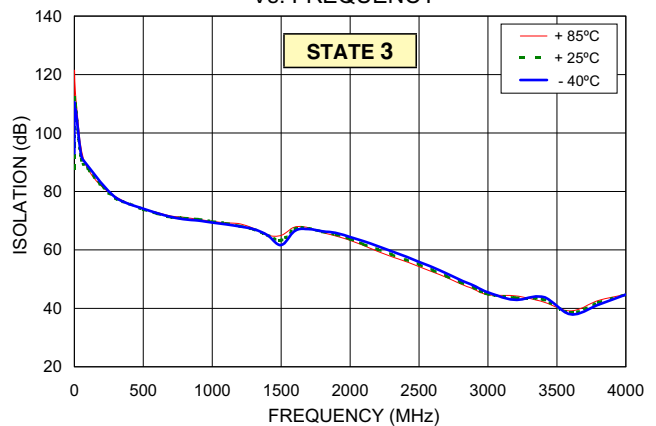

P.O. Box 350166, Brooklyn, New York 11235-0003 (718) 934-4500 Fax (718) 332-4661 For detailed performance specs & shopping online see Mini-Circuits web site



The Design Engineers Search Engine Provides ACTUAL Data Instantly From MINI-CIRCUITS At: www.minicircuits.com

RF/IF MICROWAVE COMPONENTS

SPDT RF SWITCH

ZX80-DR230+

Typical Performance Curves over various states. For switch state see Truth Table 1 on page 3.

ISOLATION BETWEEN RF1/RF2 TO RF COM
Vs. FREQUENCY

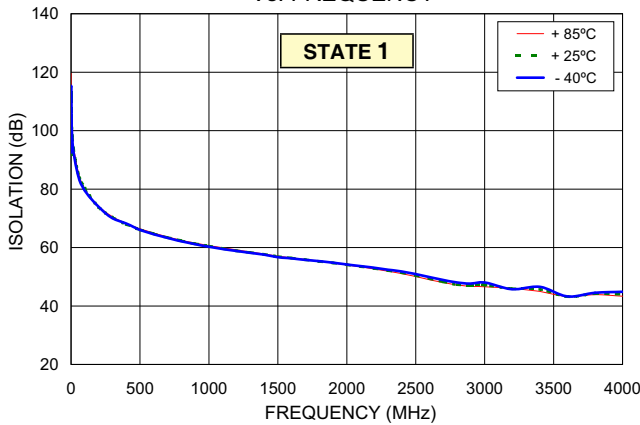

ISOLATION BETWEEN RF1 TO RF2
Vs. FREQUENCY

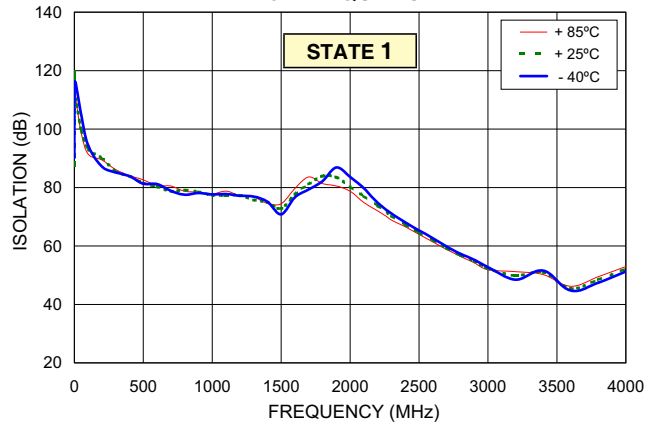

RF RETURN LOSS Vs. FREQUENCY @ +25°C

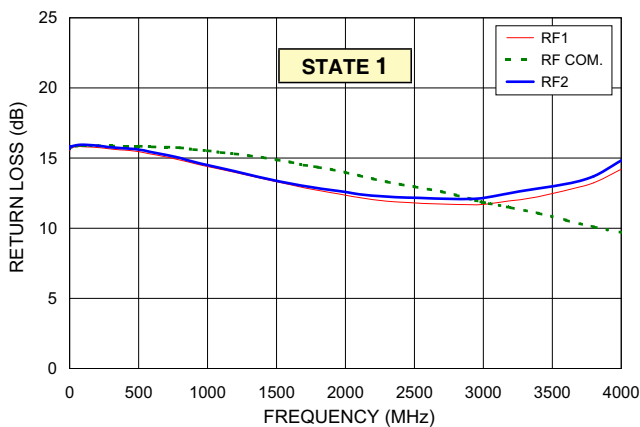

RF COM RETURN LOSS Vs. FREQUENCY @ +25°C

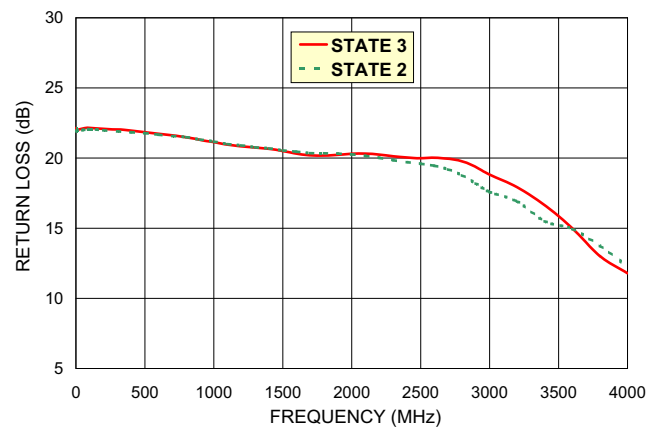

RF1 RETURN LOSS Vs. FREQUENCY

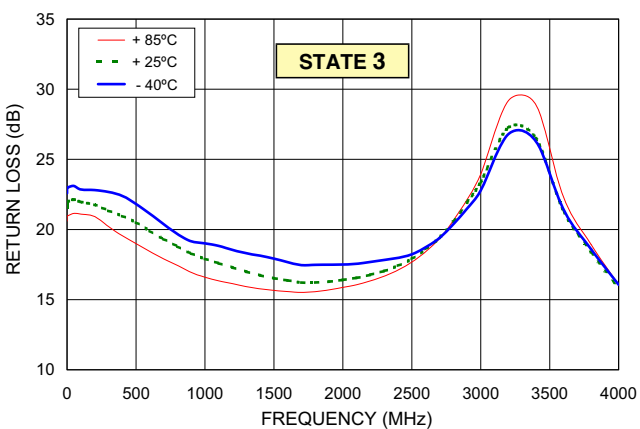

RF COM RETURN LOSS Vs. FREQUENCY

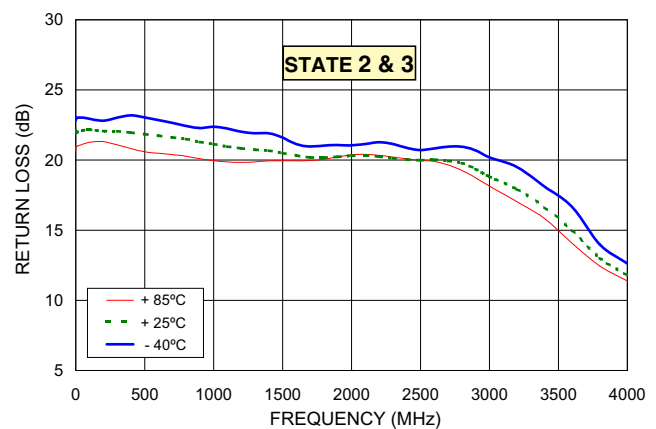

ISO 9001 ISO 14001 CERTIFIED



P.O. Box 350166, Brooklyn, New York 11235-0003 (718) 934-4500 Fax (718) 332-4661 For detailed performance specs & shopping online see Mini-Circuits web site



The Design Engineers Search Engine Provides ACTUAL Data Instantly From MINI-CIRCUITS At: www.minicircuits.com

RF/IF MICROWAVE COMPONENTS

SPDT RF SWITCH

ZX80-DR230+

Typical Performance Curves over various states. For switch state see Truth Table 1 on page 3.

RF1 RETURN LOSS Vs. FREQUENCY

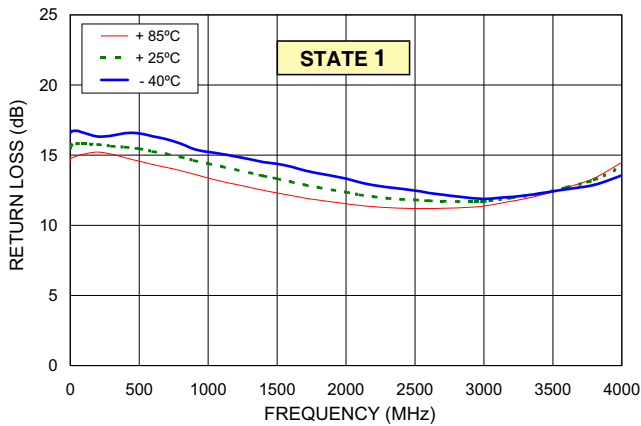

RF COM RETURN LOSS Vs. FREQUENCY

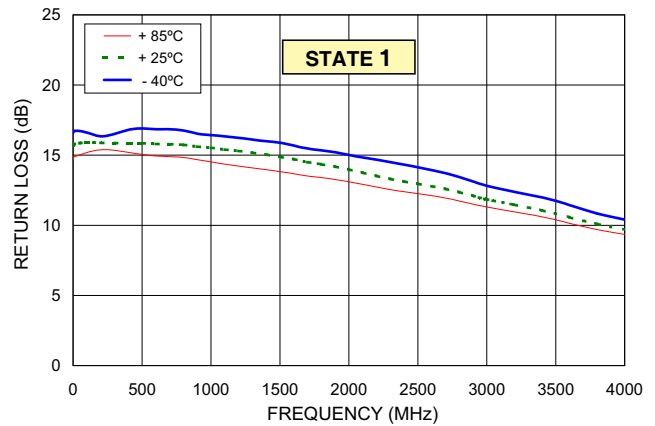

RF2 RETURN LOSS Vs. FREQUENCY

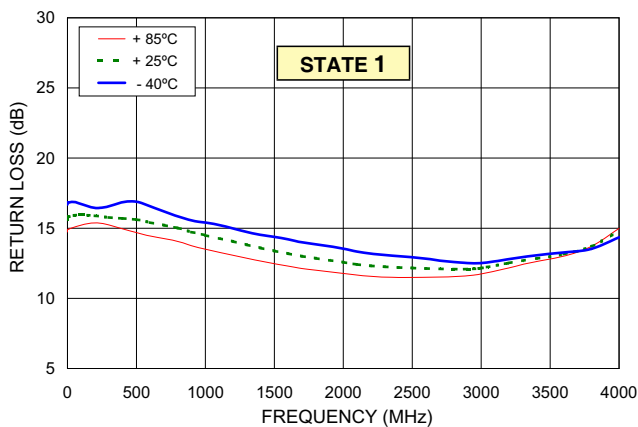

RF2 RETURN LOSS Vs. FREQUENCY

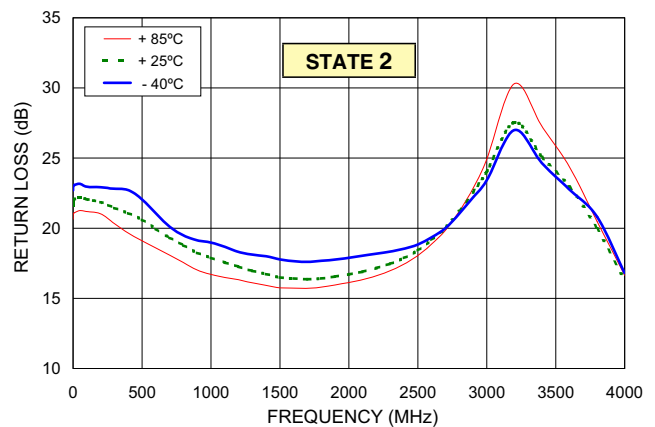

INPUT IP3 Vs. FREQUENCY

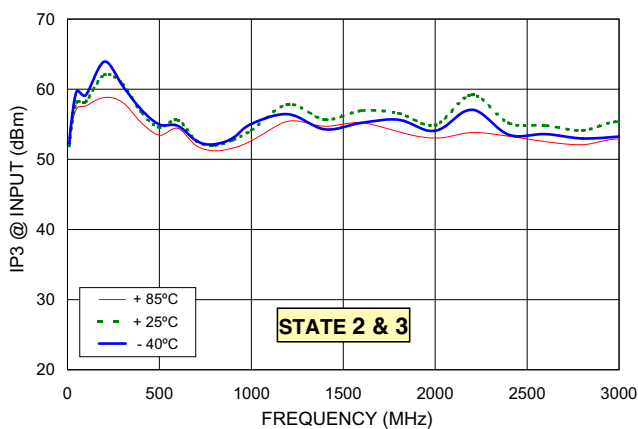

POWER IN @ 1dB COMPRESSION Vs. FREQUENCY

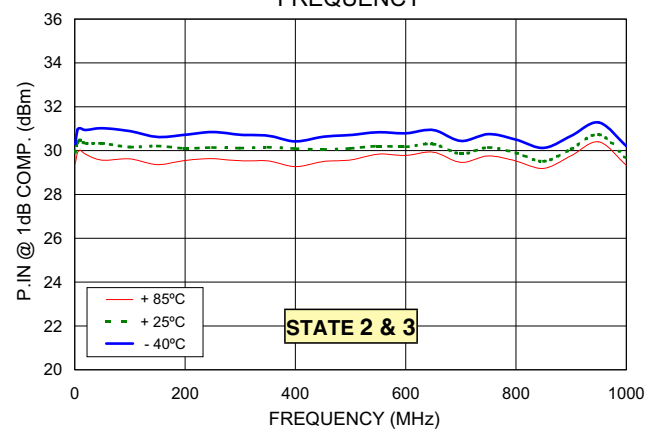

ISO 9001 ISO 14001 CERTIFIED



P.O. Box 350166, Brooklyn, New York 11235-0003 (718) 934-4500 Fax (718) 332-4661 For detailed performance specs & shopping online see Mini-Circuits web site



The Design Engineers Search Engine Provides ACTUAL Data Instantly From MINI-CIRCUITS At: www.minicircuits.com

RF/IF MICROWAVE COMPONENTS

SPDT RF SWITCH

ZX80-DR230+

Outline Drawing (HL1162)

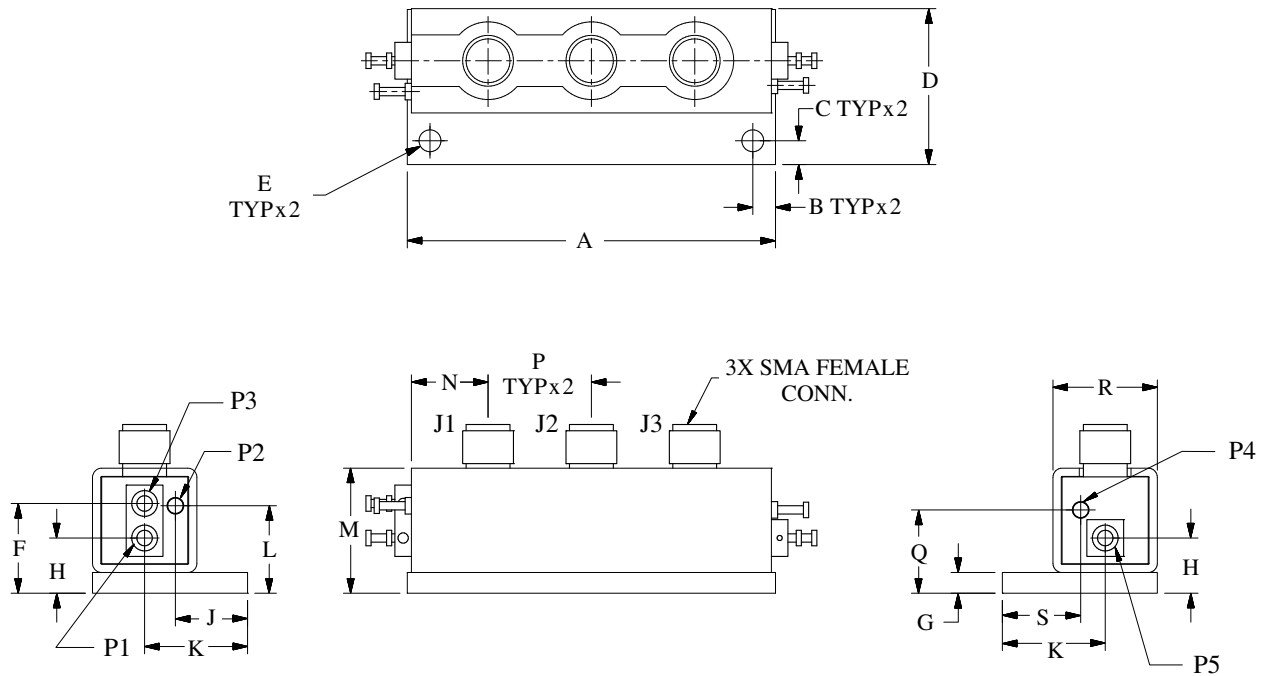

Outline Dimensions (inch mm)

A	B	C	D	E	F	G	H	J	K	L	M	N	P	Q	R	S	WT. GRAMS
1.780	.110	.115	.750	.106	.430	.100	.270	.350	.500	.420	.610	.370	.500	.400	.500	.380	56.0
45.21	2.79	2.92	19.05	2.69	10.92	2.54	6.86	8.89	12.70	10.67	15.49	9.39	12.70	10.16	12.70	9.65	



ISO 9001 ISO 14001 CERTIFIED



P.O. Box 350166, Brooklyn, New York 11235-0003 (718) 934-4500 Fax (718) 332-4661 For detailed performance specs & shopping online see Mini-Circuits web site



The Design Engineers Search Engine Provides ACTUAL Data Instantly From MINI-CIRCUITS At: www.minicircuits.com

RF/IF MICROWAVE COMPONENTS