

Coaxial

# Low Noise Amplifier

## ZQLSC-2400

50Ω 1400 to 2400 MHz

### Features

- high reliability balanced design
- noise figure, 0.9 dB typ.
- built-in alarm monitoring
- TTL alarm output, green/red alarm status LED
- voltage regulated/protected DC input

### Applications

- low noise receiver
- digital cellular base stations
- DCS, PCS, UMTS



CASE STYLE: GZ1067

Connectors	Model	Price	Qty.
SMA	ZQLSC-2400	\$295.00 ea.	(1-9)

### Low Noise Amplifier Electrical Specifications (T<sub>AMB</sub>= 25°C)

MODEL NO.	FREQUENCY (MHz)		GAIN (dB)				NOISE FIGURE (dB)		MAXIMUM POWER (dBm)			INTERCEPT POINT (dBm) IP3	VSWR (:1) Max.		DC POWER	
	f <sub>l</sub>	f <sub>u</sub>	Flatness		Typ.	Max.	Typ.	Max.	Output (1 dB Compr.)		Typ.		In	Out	Volt (V) Nom.	Current (mA) Max.
			Typ.	Max.					Typ.	Min.						
ZQLSC-2400	1400	1850	17	13.5	±1.0	±2.5	0.8	1.15	19	17	+10	37	1.7	1.6	24	185
	1850	2000	15.6	12.5	±0.5	±1.0	0.9	1.25	20.5	17	+10	35	1.5	1.6	24	185
	2000	2400	13.2	10.5	±1.5	±2.0	1.1	1.65	20	17	+10	34	1.6	1.9	24	185

### Maximum Ratings

Operating Temperature	-40°C to 80°C case
	-40°C to 60°C ambient
Storage Temperature	-55°C to 100°C
DC Voltage	+18Vmin., 36V max.

<sup>1</sup> Other voltages available in the 6.5 to 60V range, please contact factory. Permanent damage may occur if any of these limits are exceeded.

### Pin Connections

RF input	J1
RF output	J2
DC power input	5
TTL alarm output	1
Ground to test alarm, normally open	7*, 9*
No connection	3, 6, 8
Ground	2, 4
Case Ground	2, 4

\*Grounding Pin 7 will sink 75mA of current through Pin 7 creating a high-current alarm condition inside the amplifiers. A red LED and TTL high output will occur. Pin 7 floats at +4.3V typ. when open.

\*Grounding Pin 9 will sink 2mA of current through pin 9 and creating a low-current alarm condition inside the amplifier. A red LED and TTL high output will occur. Pin 9 floats at about +0.6V typ. when open.

### Outline Drawing

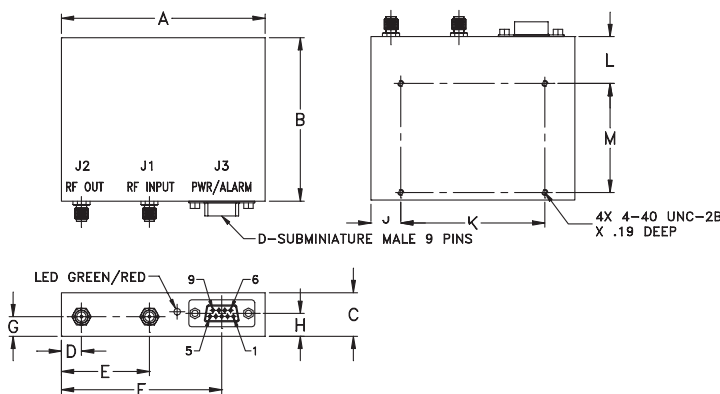

### Alarm Functions

Normal:	TTL low output (0 to 0.8V), green LED
Alarm:	TTL high output (4 to 5V), red LED
DC & alarm connector:	9-pin male D-sub

### Outline Dimensions (inch/mm)

A	B	C	D	E	F	G	H	J	K	L	M	wt
3.75	3.00	.80	.37	1.62	2.95	.36	.42	.55	2.650	.86	2.000	grams
95.25	76.20	20.32	9.40	41.15	74.93	9.14	10.67	13.97	67.31	21.84	50.80	280.0

**Mini-Circuits**  
ISO 9001 ISO 14001 AS 9100 CERTIFIED

For detailed performance specs & shopping online see web site

P.O. Box 350166, Brooklyn, New York 11235-0003 (718) 934-4500 Fax (718) 332-4661 The Design Engineers Search Engine Provides ACTUAL Data Instantly at [minicircuits.com](http://minicircuits.com)

IF/RF MICROWAVE COMPONENTS

Notes: 1. Performance and quality attributes and conditions not expressly stated in this specification sheet are intended to be excluded and do not form a part of this specification sheet. 2. Electrical specifications and performance data contained herein are based on Mini-Circuit's applicable established test performance criteria and measurement instructions. 3. The parts covered by this specification sheet are subject to Mini-Circuits standard limited warranty and terms and conditions (collectively, "Standard Terms"); Purchasers of this part are entitled to the rights and benefits contained therein. For a full statement of the Standard Terms and the exclusive rights and remedies thereunder, please visit Mini-Circuits' website at [www.minicircuits.com/MCLStore/terms.jsp](http://www.minicircuits.com/MCLStore/terms.jsp).

REV. A  
M93728  
ZQLSC-2400  
EDB020910  
BLUE C/TD/CP  
090819  
Page 1 of 2

FREQUENCY (MHz)	GAIN (dB)	DIRECTIVITY (dB)	VSWR (:1) 24V		POUT at 1 dB COMPR. (dBm)	IP3 (dBm)	NOISE FIGURE (dB)
	24V		IN	OUT			
1400.00	18.49	7.71	1.33	1.22	18.14	45.58	0.77
1500.00	18.10	7.56	1.21	1.17	18.60	45.50	0.84
1600.00	17.52	7.90	1.14	1.13	19.03	42.00	0.73
1700.00	16.92	8.25	1.12	1.10	19.51	39.51	0.69
1800.00	16.35	8.61	1.08	1.10	20.08	38.02	0.73
1900.00	15.78	9.00	1.07	1.12	20.60	37.91	0.72
2000.00	15.12	9.62	1.09	1.17	20.73	37.08	0.77
2100.00	14.43	10.25	1.15	1.27	20.34	36.47	0.81
2200.00	13.75	11.07	1.22	1.36	19.84	35.91	0.79
2300.00	13.03	11.75	1.28	1.42	19.19	35.23	0.83
2400.00	11.86	13.23	1.29	1.45	18.87	35.05	0.87

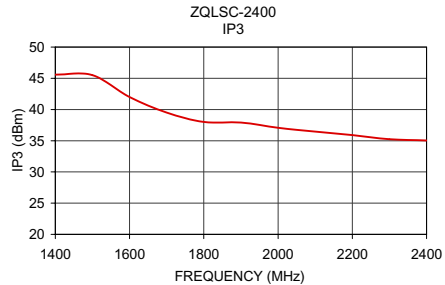
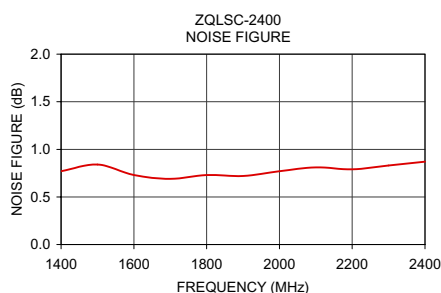
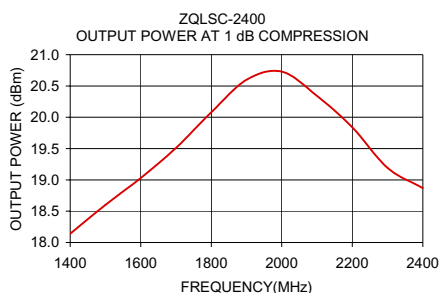
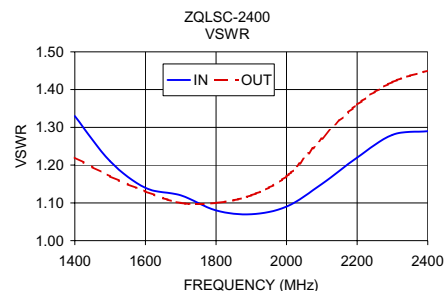
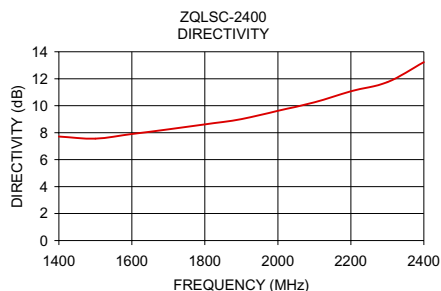
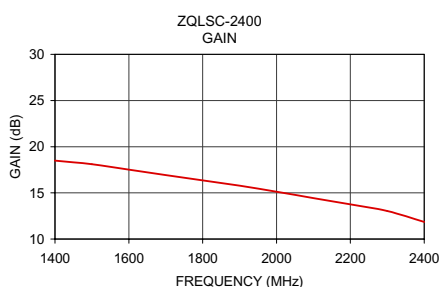

For detailed performance specs & shopping online see web site

P.O. Box 350166, Brooklyn, New York 11235-0003 (718) 934-4500 Fax (718) 332-4661 The Design Engineers Search Engine Provides ACTUAL Data Instantly at [minicircuits.com](http://minicircuits.com)

IF/RF MICROWAVE COMPONENTS

Notes: 1. Performance and quality attributes and conditions not expressly stated in this specification sheet are intended to be excluded and do not form a part of this specification sheet. 2. Electrical specifications and performance data contained herein are based on Mini-Circuit's applicable established test performance criteria and measurement instructions. 3. The parts covered by this specification sheet are subject to Mini-Circuits standard limited warranty and terms and conditions (collectively, "Standard Terms"); Purchasers of this part are entitled to the rights and benefits contained therein. For a full statement of the Standard Terms and the exclusive rights and remedies thereunder, please visit Mini-Circuits' website at [www.minicircuits.com/MCLStore/terms.jsp](http://www.minicircuits.com/MCLStore/terms.jsp).