

Coaxial

Low Noise Amplifier

ZQL-1900MLNW+

50Ω 1800 to 2000 MHz

Features

- very low noise, 1.6 dB max.
- high IP3, +41dBm typ.
- rugged, shielded case

Applications

- PCS
- mobile satellite service
- UMTS



CASE STYLE: CW686

Connectors	Model	Price	Qty.
SMA	ZQL-1900MLNW+	\$249.00 ea.	(1-9)

+ RoHS compliant in accordance with EU Directive (2002/95/EC)

The +Suffix has been added in order to identify RoHS Compliance. See our web site for RoHS Compliance methodologies and qualifications.

Low Noise Amplifier Electrical Specifications

MODEL NO.	FREQUENCY (MHz)		NOISE FIGURE (dB) Max.	GAIN (dB)		MAXIMUM POWER (dBm)		INTERCEPT POINT (dBm) IP3 Typ.	VSWR (:1) Typ.*		DC POWER	
	f _L	f _U		Min.	Flatness Max.	Output (1 dB Compr.) Typ.	Input (no damage)		In	Out	Volt (V) Nom.	Current (mA) Max.
ZQL-1900MLNW+	1800	2000	1.6	23	±2.0	+25	+3	+41	1.4	1.25	15	310

Open load is not recommended, potentially can cause damage.
With no load derate max input power by 20 dB
*Measured at 1900 MHz

Maximum Ratings

Operating Temperature -40°C to 70°C
Storage Temperature -55°C to 100°C
DC Voltage +17V Max.
Permanent damage may occur if any of these limits are exceeded.

Outline Drawing

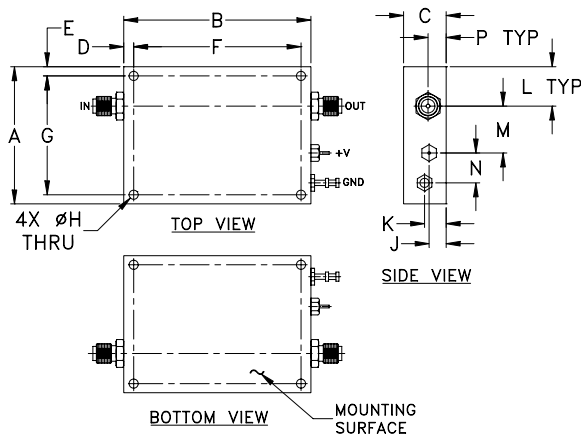

Outline Dimensions (inch/mm)

A	B	C	D	E	F	G	H	J	K	L	M	N	P	wt
1.77	2.42	.55	.13	.12	2.165	1.535	.126	.22	.28	.51	.61	.39	0.22	grams
44.96	61.47	13.97	3.30	3.05	55.0	39.0	3.20	5.59	7.11	12.95	15.49	9.91	5.59	71.0

Mini-Circuits®
ISO 9001 ISO 14001 AS 9100 CERTIFIED

For detailed performance specs & shopping online see web site

P.O. Box 350166, Brooklyn, New York 11235-0003 (718) 934-4500 Fax (718) 332-4661 The Design Engineers Search Engine Provides ACTUAL Data Instantly at minicircuits.com

IF/RF MICROWAVE COMPONENTS

Notes: 1. Performance and quality attributes and conditions not expressly stated in this specification sheet are intended to be excluded and do not form a part of this specification sheet. 2. Electrical specifications and performance data contained herein are based on Mini-Circuit's applicable established test performance criteria and measurement instructions. 3. The parts covered by this specification sheet are subject to Mini-Circuits standard limited warranty and terms and conditions (collectively, "Standard Terms"); Purchasers of this part are entitled to the rights and benefits contained therein. For a full statement of the Standard Terms and the exclusive rights and remedies thereunder, please visit Mini-Circuits' website at www.minicircuits.com/MCLStore/terms.jsp.

Typical Performance Data/Curves

ZQL-1900MLNW+

FREQUENCY (MHz)	GAIN (dB)	DIRECTIVITY (dB)	VSWR (:1)		NOISE FIGURE (dB)	POUT at 1 dB COMPR. (dBm)
	15V	15V	IN	OUT	15V	15V
1800.00	27.96	16.90	1.22	1.28	1.16	27.59
1850.00	27.36	17.00	1.28	1.14	1.18	27.48
1859.00	27.27	17.20	1.30	1.12	1.18	27.49
1865.00	27.22	17.30	1.30	1.11	1.17	27.37
1874.00	27.14	17.70	1.31	1.10	1.17	27.35
1886.00	27.05	17.90	1.33	1.08	1.18	27.23
1895.00	26.96	17.60	1.34	1.08	1.18	27.17
1901.00	26.89	17.20	1.34	1.08	1.18	27.09
1910.00	26.80	18.40	1.34	1.08	1.16	27.11
2000.00	26.03	18.40	1.35	1.25	1.14	26.58

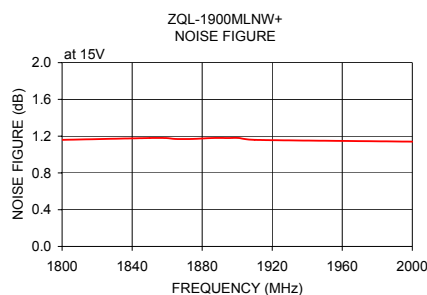
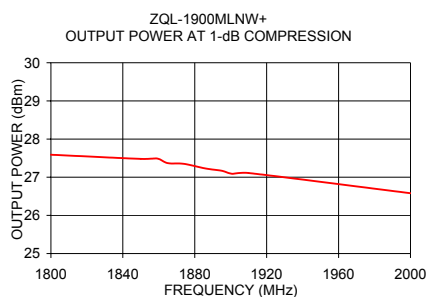
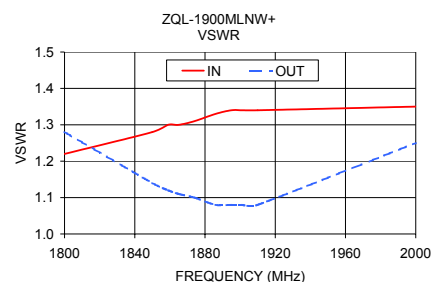
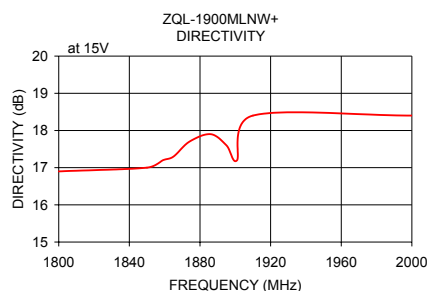
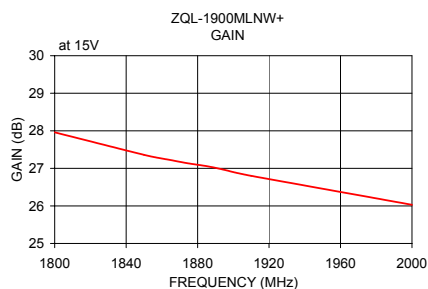

Mini-Circuits®
ISO 9001 ISO 14001 AS 9100 CERTIFIED

For detailed performance specs & shopping online see web site page 2 of 2

P.O. Box 350166, Brooklyn, New York 11235-0003 (718) 934-4500 Fax (718) 332-4661 The Design Engineers Search Engine Provides ACTUAL Data Instantly at minicircuits.com

IF/RF MICROWAVE COMPONENTS

Notes: 1. Performance and quality attributes and conditions not expressly stated in this specification sheet are intended to be excluded and do not form a part of this specification sheet. 2. Electrical specifications and performance data contained herein are based on Mini-Circuit's applicable established test performance criteria and measurement instructions. 3. The parts covered by this specification sheet are subject to Mini-Circuits standard limited warranty and terms and conditions (collectively, "Standard Terms"); Purchasers of this part are entitled to the rights and benefits contained therein. For a full statement of the Standard Terms and the exclusive rights and remedies thereunder, please visit Mini-Circuits' website at www.minicircuits.com/MCLStore/terms.jsp.