

Coaxial Frequency Mixer

ZP-3LH+

Level 10 (LO Power +10 dBm) 0.15 to 400 MHz



Maximum Ratings

Operating Temperature	-55°C to 100°C
Storage Temperature	-55°C to 100°C
RF Power	50mW
IF Current	40mA

Permanent damage may occur if any of these limits are exceeded.

Coaxial Connections

LO	L
RF	R
IF	X

Features

- low conversion loss, 4.8 dB typ.
- high L-R isolation, 51 dB typ., L-I, 45 dB typ.
- IF response to DC
- rugged shielded case

Applications

- VHF/UHF
- instrumentation

BNC version shown

CASE STYLE: GG60

Connectors	Model	Price	Qty.
BNC	ZP-3LH+	\$41.95 ea.	(1-9)
SMA	ZP-3LH-S+	\$46.95 ea.	(1-9)

+ RoHS compliant in accordance with EU Directive (2002/95/EC)

The +Suffix has been added in order to identify RoHS Compliance. See our web site for RoHS Compliance methodologies and qualifications.

Outline Drawing

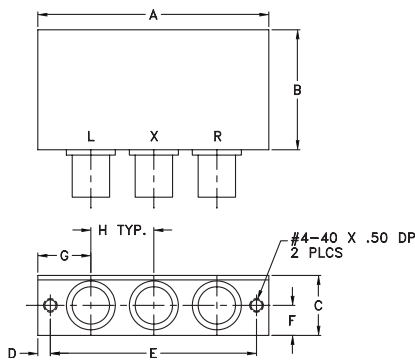

Outline Dimensions (inch/mm)

A	B	C	D	E	F	G	H	wt
2.31	1.20	.60	.125	2.062	.30	.53	.63	grams
58.67	30.48	15.24	3.18	52.37	7.62	13.46	16.00	75.0

Electrical Specifications

FREQUENCY (MHz)	CONVERSION LOSS (dB)	LO-RF ISOLATION (dB)						LO-IF ISOLATION (dB)									
		Mid-Band m		Total Range		L		M		U		L		M		U	
LO/RF f_L-f_U	\bar{X} σ Max.	Max.	Max.	Typ.	Min.	Typ.	Min.	Typ.	Min.	Typ.	Min.	Typ.	Min.	Typ.	Min.	Typ.	Min.
0.15-400	DC-400	4.8	0.37	7.0	8.0	67	50	51	30	40	25	67	40	45	25	34	20

1 dB COMP.: +5 dBm typ.

L = low range [f_L to $10 f_L$] M = mid range [$10 f_L$ to $f_U/2$] U = upper range [$f_U/2$ to f_U]
m = mid band [$2f_L$ to $f_U/2$]

Typical Performance Data

Frequency (MHz)	Conversion Loss (dB)	Isolation L-R (dB)	Isolation L-I (dB)	VSWR RF Port (:1)	VSWR LO Port (:1)
0.15	30.15	4.98	69.38	1.21	2.67
0.30	30.30	4.90	69.38	1.15	2.64
0.50	30.50	4.83	69.26	1.10	2.57
1.00	31.00	4.74	69.26	1.06	2.52
1.50	31.50	4.69	69.08	1.03	2.36
2.00	32.00	4.66	68.95	1.02	2.40
5.00	35.00	4.62	68.20	1.01	2.33
10.00	40.00	4.59	66.47	1.02	2.31
20.00	50.00	4.68	63.23	1.02	2.25
50.00	80.00	4.66	56.07	1.02	2.25
57.27	87.27	4.67	54.97	1.01	2.29
100.00	70.00	4.67	50.23	1.01	2.25
114.39	84.39	4.68	48.98	1.01	2.28
171.51	14.15	4.80	45.17	1.01	2.33
200.00	170.00	4.81	42.29	1.01	2.44
228.64	198.64	4.90	41.00	1.04	2.39
285.76	255.76	5.11	48.00	1.09	2.41
342.88	312.88	5.17	39.79	1.20	2.58
385.72	356.72	5.29	34.24	1.23	2.76
400.00	370.00	5.48	34.34	1.27	2.78

Electrical Schematic

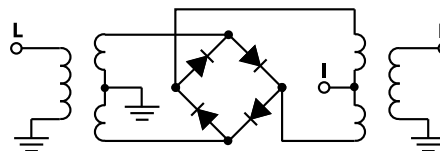

Mini-Circuits
ISO 9001 ISO 14001 AS 9100 CERTIFIED

P.O. Box 350166, Brooklyn, New York 11235-0003 (718) 934-4500 Fax (718) 332-4661 The Design Engineers Search Engine Provides ACTUAL Data Instantly at minicircuits.com

For detailed performance specs & shopping online see web site

Notes: 1. Performance and quality attributes and conditions not expressly stated in this specification sheet are intended to be excluded and do not form a part of this specification sheet. 2. Electrical specifications and performance data contained herein are based on Mini-Circuit's applicable established test performance criteria and measurement instructions. 3. The parts covered by this specification sheet are subject to Mini-Circuit's standard limited warranty and terms and conditions (collectively, "Standard Terms"); Purchasers of this part are entitled to the rights and benefits contained therein. For a full statement of the Standard Terms and the exclusive rights and remedies thereunder, please visit Mini-Circuit's website at www.minicircuits.com/MCLStore/terms.jsp.

REV. B
M113397
ZP-3LH+
DJ/TD/CP/AM
081110
Page 1 of 2

