

High Power Directional Coupler

ZGDC6-362HP+

50Ω 6dB 380 to 3600 MHz

The Big Deal

- High Power Handling: 250W
- Low Insertion Loss: 0.20 dB*
- Rugged IP67 Weatherproof case



CASE STYLE: HT1398

Product Overview

The Mini-Circuits ZGDC6-362HP+ broadband high power directional coupler offers excellent performance across a wide range of popular frequency bands. Built using low loss suspended substrate construction, the ZGDC6-362HP+ can pass up to 3A of DC current from input to output and handle up to 250W CW. The rugged sealed construction makes this coupler ideal for use in field applications or remote monitoring sites; however, it is also ideal for high power lab testing.

Key Features

Feature	Advantages
Excellent Insertion Loss , 0.20 dB Typ*	With extremely low insertion loss, this coupler is ideal for critical high power applications.
Ultra High Return Loss, 30 dB Typ	Outstanding Return loss makes this coupler ideal for sensitive power measurement and other signal distribution applications.
High Power Handling, 250W	Up to 250W CW power handling, combined with low insertion loss and excellent VSWR support operation in high power applications such as transmitters, base stations and high power device characterization.
Wide bandwidth	Covering 380-3600 MHz, the ZGDC6-362HP+ covers the most popular Cellular, PCS, DCS, WiMAX, and LTE bands.
Excellent Directivity and Coupling Flatness	Typical 28 dB directivity and ± 0.6 dB of Coupling flatness provides accurate signal sampling of forward or reflected power.
Passes DC Current, 3A	Capable of passing 3A current, input to output; this coupler is suited for application using remote antenna control or other remote motorized requirements.
IP67 Weatherproof Case	With an Ingress Protection rating of IP67, the ZGDC6-362HP+ is designed to operate in harsh outdoor applications.

*Does not include coupling loss



ISO 9001 ISO 14001 AS 9100 CERTIFIED

P.O. Box 350166, Brooklyn, New York 11235-0003 (718) 934-4500 Fax (718) 332-4661 The Design Engineers Search Engine Provides ACTUAL Data Instantly at minicircuits.com

IF/RF MICROWAVE COMPONENTS

For detailed performance specs & shopping online see web site

Notes: 1. Performance and quality attributes and conditions not expressly stated in this specification sheet are intended to be excluded and do not form a part of this specification sheet. 2. Electrical specifications and performance data contained herein are based on Mini-Circuit's applicable established test performance criteria and measurement instructions. 3. The parts covered by this specification sheet are subject to Mini-Circuits standard limited warranty and terms and conditions (collectively, "Standard Terms"); Purchasers of this part are entitled to the rights and benefits contained therein. For a full statement of the Standard Terms and the exclusive rights and remedies thereunder, please visit Mini-Circuits' website at www.minicircuits.com/MCLStore/terms.jsp.

6dB DC Pass

High Power Directional Coupler

ZGDC6-362HP+

50Ω Up to 250W

380 to 3600 MHz



Maximum Ratings

Operating Temperature	-55°C to 100°C
Storage Temperature	-55°C to 100°C
DC Current	3A
Supplied Termination	10W*

*Derate linearly by 0.18W/°C from 70°C to 100°C
Permanent damage may occur if any of these limits are exceeded

Coaxial Connections

INPUT	IN
OUTPUT	OUT
COUPLED	CPL
TERMINATION (50Ω), INTERNAL	TERM

Outline Drawing

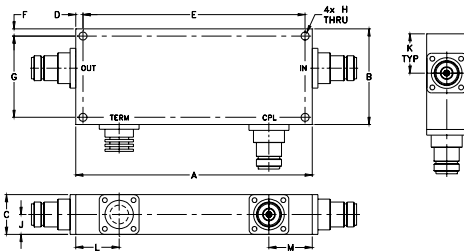

Outline Dimensions (inch/mm)

A	B	C	D	E	F	G	
5.93	2.40	1.00	.18	5.565	.18	2.040	
150.62	60.96	25.40	4.57	141.35	4.57	51.82	
H	J	K	L	M			wt
.200	.50	.99	1.09	1.09			grams
5.08	12.70	25.15	27.69	27.69			700.0

IP protection classification: IP67

Features

- wide frequency range, 380-3600 MHz
- good coupling flatness, ±0.3 dB typ. (600-3600 MHz)
- high directivity, 20 dB typ.
- very good VSWR, 1.05:1 typ.
- high power, up to 250W
- DC current pass through input to output
- IP67 weather proof case

Applications

- cellular
- lab use
- WiMAX
- PCN
- GSM
- ISM

CASE STYLE: HT1398			
Connectors	Model	Price	Qty.
N-Type	ZGDC6-362HP+	\$169.95 ea.	(1-9)

+ RoHS compliant in accordance with EU Directive (2002/95/EC)

The +Suffix has been added in order to identify RoHS Compliance. See our web site for RoHS Compliance methodologies and qualifications.

Electrical Specifications at 25°C

Parameter	Frequency (MHz)	Min.	Typ.	Max.	Units
Operating Frequency		380		3600	MHz
Coupling	380-600	—	7.2±1.4	—	
	600-2700	—	6.3±0.6	—	dB
	2700-3600	—	6.3±0.4	—	
Coupling Flatness	380-600	—	—	±1.25	
	600-2700	—	—	±0.75	dB
	2700-3600	—	—	±0.4	
Mainline Loss ¹	380-600	—	0.06	0.2	
	600-2700	—	0.20	0.5	dB
	2700-3600	—	0.29	0.6	
Directivity	380-600	20	29	—	
	600-2700	20	26	—	dB
	2700-3600	16	23	—	
VSWR	380-600	—	1.05	—	
	600-2700	—	1.05	—	:1
	2700-3600	—	1.1	—	
Input Power ²	380-600	—	—	250	
	600-2700	—	—	250	W
	2700-3600	—	—	150	

1. Does not include coupling loss.

2. At 25°C with no DC current. Derate linearly to 100W (380-2700 MHz) and to 64W (2700-3600 MHz) from 25°C to 100°C. Output load VSWR 2.0:1 max.

Electrical Schematic

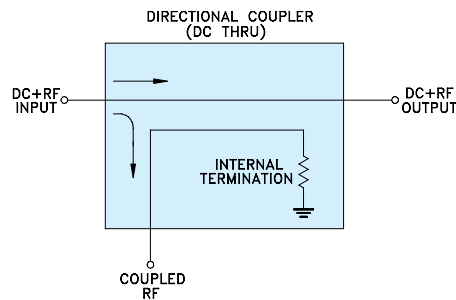

Mini-Circuits®

ISO 9001 ISO 14001 AS 9100 CERTIFIED



P.O. Box 350166, Brooklyn, New York 11235-0003 (718) 934-4500 Fax (718) 332-4661 The Design Engineers Search Engine Provides ACTUAL Data Instantly at minicircuits.com

IF/RF MICROWAVE COMPONENTS

For detailed performance specs & shopping online see web site

Notes: 1. Performance and quality attributes and conditions not expressly stated in this specification sheet are intended to be excluded and do not form a part of this specification sheet. 2. Electrical specifications and performance data contained herein are based on Mini-Circuit's applicable established test performance criteria and measurement instructions. 3. The parts covered by this specification sheet are subject to Mini-Circuits standard limited warranty and terms and conditions (collectively, "Standard Terms"); Purchasers of this part are entitled to the rights and benefits contained therein. For a full statement of the Standard Terms and the exclusive rights and remedies thereunder, please visit Mini-Circuits' website at www.minicircuits.com/MCLStore/terms.jsp.

REV. OR
M125696
ED-13551/1
ZGDC6-362HP+
MCL NY
091221
Page 2

Typical Performance Data

Frequency (MHz)	Mainline Loss ⁽¹⁾ (dB)		Coupling (dB) In-Cpl	Directivity (dB)	Return Loss (dB)		
	In-Out				In	Out	Cpl
380.0	0.04		8.09	32.60	36.39	37.92	34.86
600.0	0.06		6.45	30.43	27.96	29.77	33.43
700.0	0.07		6.25	29.35	28.10	30.71	35.69
1000.0	0.08		6.39	27.09	37.66	30.36	32.54
1600.0	0.12		6.02	31.59	38.97	40.35	34.72
2000.0	0.15		6.31	30.15	40.26	53.93	33.91
2200.0	0.16		6.21	30.85	31.87	34.49	33.58
2500.0	0.19		6.15	28.23	25.78	28.99	33.92
2700.0	0.19		6.36	30.49	26.95	28.70	32.39
2800.0	0.20		6.47	32.44	29.88	31.17	32.64
3200.0	0.23		6.42	25.24	25.58	30.03	34.81
3600.0	0.28		6.58	23.24	21.92	26.58	20.98

1. Does not include coupling loss.

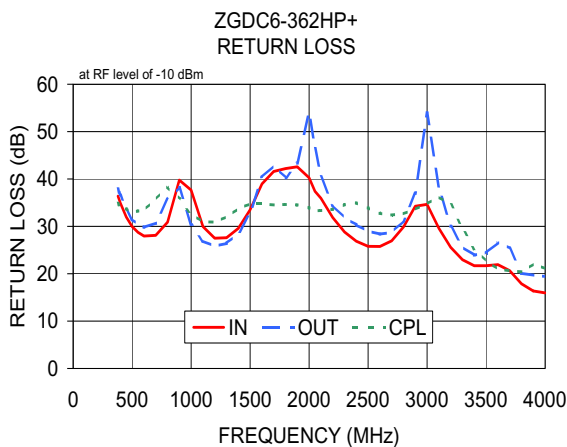
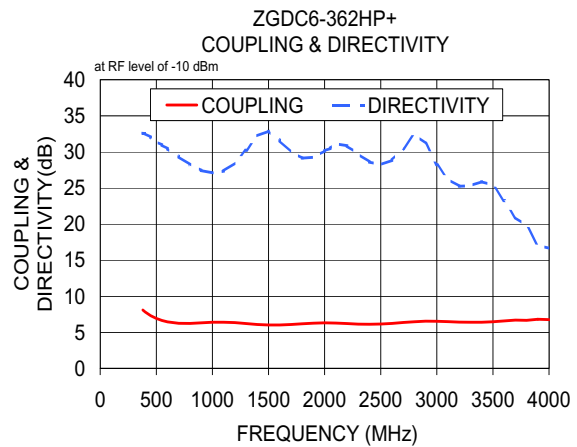
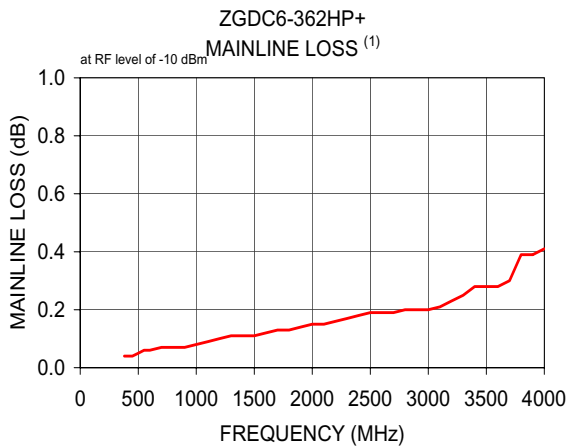

ISO 9001 ISO 14001 AS 9100 CERTIFIED

For detailed performance specs & shopping online see web site

P.O. Box 350166, Brooklyn, New York 11235-0003 (718) 934-4500 Fax (718) 332-4661 The Design Engineers Search Engine Provides ACTUAL Data Instantly at minicircuits.com

IF/RF MICROWAVE COMPONENTS

Notes: 1. Performance and quality attributes and conditions not expressly stated in this specification sheet are intended to be excluded and do not form a part of this specification sheet. 2. Electrical specifications and performance data contained herein are based on Mini-Circuit's applicable established test performance criteria and measurement instructions. 3. The parts covered by this specification sheet are subject to Mini-Circuits standard limited warranty and terms and conditions (collectively, "Standard Terms"); Purchasers of this part are entitled to the rights and benefits contained therein. For a full statement of the Standard Terms and the exclusive rights and remedies thereunder, please visit Mini-Circuits' website at www.minicircuits.com/MCLStore/terms.jsp.