

# Power Splitter/Combiner

## ZFSCJ-2-232+

2 Way-180° 50Ω 5 to 2300 MHz



### Maximum Ratings

Operating Temperature	-55°C to 100°C
Storage Temperature	-55°C to 100°C
Power Input (as a splitter)	0.25W max.

Permanent damage may occur if any of these limits are exceeded.

### Coaxial Connections

SUM PORT	3
PORT 1	1
PORT 2	2

### Outline Drawing

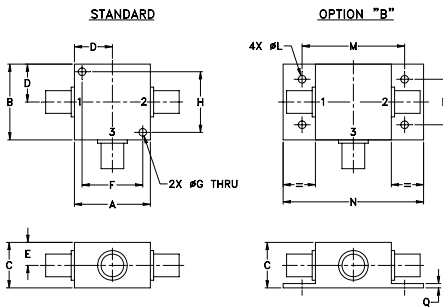

### Outline Dimensions (inch/mm)

A	B	C	D	E	F	G	H
1.25	1.25	.75	.63	.38	1.00	.125	1.000
31.75	31.75	19.05	16.00	9.65	25.40	3.18	25.40
J	K	L	M	N	P	Q	wt
--	--	.125	1.688	2.18	.75	.07	grams
--	--	3.18	42.88	55.37	19.05	1.78	70.0

### Features

- wide band frequency, 5-2300 MHz
- usable up to 3000 MHz
- good phase unbalance, 180±3°typ.
- excellent amplitude unbalance, 0.3 dB typ.
- rugged shielded case

### Applications

- VHF/UHF
- cellular
- signal processing
- PCS
- GPS

### Electrical Specifications at 25°C

Parameter	Frequency (MHz)	Min.	Typ.	Max.	Unit
<b>Frequency</b>		5		2300	MHz
<b>Insertion Loss (above theoretical 3.0 dB)</b>	5-2300	—	1.9	3.8	dB
<b>Isolation</b>	5-2300	—	4	—	dB
<b>Phase Unbalance</b>	5-2300	—	3	6	Degree
<b>Amplitude Unbalance</b>	5-2300	—	0.2	0.6	dB
<b>VSWR (Port S)</b>	5-2300	—	1.7	—	:1
<b>VSWR (Port 1-2)</b>	5-2300	—	1.9	—	:1

### Typical Performance Data

Frequency (MHz)	Total Loss <sup>1</sup> (dB)		Amplitude Unbalance (dB)	Isolation (dB)	Phase Unbalance (deg.)	VSWR S	VSWR 1	VSWR 2
	S-1	S-2						
5.00	4.28	4.30	0.02	3.86	179.70	1.61	1.71	1.71
50.00	4.26	4.27	0.01	3.91	179.92	1.63	1.74	1.74
100.00	4.29	4.30	0.01	4.02	179.80	1.62	1.76	1.76
500.00	4.05	4.11	0.06	5.45	179.92	1.31	2.11	2.09
800.00	4.09	4.09	0.00	6.12	179.49	1.22	2.28	2.23
1000.00	4.34	4.29	0.05	5.70	178.94	1.46	2.20	2.14
1200.00	4.62	4.56	0.06	5.09	178.35	1.71	2.05	1.98
1400.00	4.81	4.78	0.03	4.73	177.86	1.84	1.93	1.85
1600.00	4.85	4.89	0.04	4.81	177.50	1.77	1.94	1.84
1800.00	4.82	4.95	0.13	5.19	177.43	1.52	2.05	1.93
2000.00	4.93	5.15	0.22	5.29	177.60	1.27	2.11	1.99
2100.00	5.09	5.36	0.27	5.04	177.68	1.28	2.06	1.95
2200.00	5.34	5.64	0.30	4.61	177.85	1.40	1.95	1.85
2300.00	5.64	6.00	0.36	4.14	178.01	1.59	1.81	1.72

1. Total Loss = Insertion Loss + 3dB splitter loss.

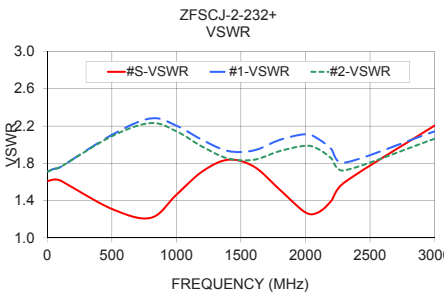
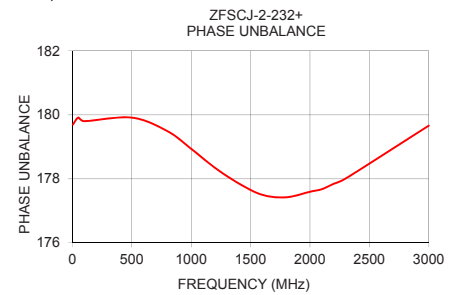
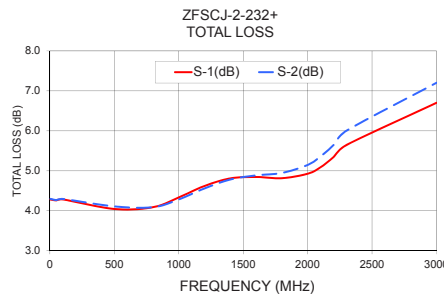

### Electrical Schematic



### Notes

- Performance and quality attributes and conditions not expressly stated in this specification document are intended to be excluded and do not form a part of this specification document.
- Electrical specifications and performance data contained in this specification document are based on Mini-Circuit's applicable established test performance criteria and measurement instructions.
- The parts covered by this specification document are subject to Mini-Circuits standard limited warranty and terms and conditions (collectively, "Standard Terms"); Purchasers of this part are entitled to the rights and benefits contained therein. For a full statement of the Standard Terms and the exclusive rights and remedies thereunder, please visit Mini-Circuits' website at [www.minicircuits.com/MCLStore/terms.jsp](http://www.minicircuits.com/MCLStore/terms.jsp)

REV. OR  
M131114  
ZFSCJ-2-232+  
WZ/CP/AM  
150923

