

Coaxial

# Power Splitter/Combiner

## ZFSC-2-1W+

2 Way-0° 50Ω 1 to 750 MHz



BNC version shown  
CASE STYLE: K18

### Maximum Ratings

Operating Temperature	-55°C to 100°C
Storage Temperature	-55°C to 100°C
Power Input (as a splitter)	1W max.
Internal Dissipation	0.125W max.

Permanent damage may occur if any of these limits are exceeded.

### Coaxial Connections

SUM PORT	3
PORT 1	1
PORT 2	2

### Outline Drawing

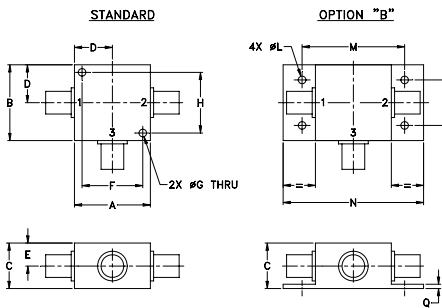

### Outline Dimensions (inch/mm)

A	B	C	D	E	F	G	H	J	K	L	M	N	P	Q	wt
1.25	1.25	.75	.63	.38	1.00	.125	1.000	--	--	.125	1.688	2.18	.75	.07	grams
31.75	31.75	19.05	16.00	9.65	25.40	3.18	25.40	--	--	3.18	42.88	55.37	19.05	1.78	70.0

For option B with N-type connectors, dimension "C" increases to 0.94 inches.

### Features

- low insertion loss, 0.4 dB typ.
- high isolation, 28 dB typ.
- excellent amplitude unbalance, 0.1 dB typ.
- excellent phase unbalance, 0.5 deg. typ.
- very good return loss, VSWR, 1.15:1 typ.
- rugged shielded case

### Applications

- VHF/UHF
- federal & defense communication

Connectors	Model	Price	Qty.
BNC	ZFSC-2-1W+	\$48.95	(1-9)
SMA	ZFSC-2-1W-S+	\$53.95	(1-9)
N-TYPE	ZFSC-2-1W-N+	\$53.95	(1-9)
BRACKET (OPTION "B")		\$2.50	(1+)

+ RoHS compliant in accordance with EU Directive (2002/95/EC)

The +Suffix has been added in order to identify RoHS Compliance. See our web site for RoHS Compliance methodologies and qualifications.

### Electrical Specifications

FREQ. RANGE (MHz)	ISOLATION (dB)						INSERTION LOSS (dB) ABOVE 3.0 dB						PHASE UNBALANCE (Degrees)			AMPLITUDE UNBALANCE (dB)		
	L		M		U		L		M		U		L	M	U	L	M	U
	Typ.	Min.	Typ.	Min.	Typ.	Min.	Typ.	Max.	Typ.	Max.	Typ.	Max.	Max.	Max.	Max.	Max.	Max.	Max.
1-750	30	20	28	20	25	20	0.2	0.5	0.4	0.8	0.8	1.0	2	4	4	0.15	0.15	0.30

L = low range [ $f_L$  to  $10 f_L$ ] M = mid range [ $10 f_L$  to  $f_U/2$ ] U = upper range [ $f_U/2$  to  $f_U$ ]

### Typical Performance Data

Frequency (MHz)	Insertion Loss (dB)		Amplitude Unbalance (dB)	Isolation (dB)	Phase Unbalance (deg.)	VSWR S	VSWR 1	VSWR 2
	S-1	S-2						
1.00	3.27	3.27	0.00	31.01	0.01	1.10	1.22	1.21
5.00	3.17	3.16	0.01	38.19	0.02	1.08	1.17	1.16
10.00	3.16	3.16	0.00	38.65	0.14	1.08	1.16	1.16
68.00	3.19	3.19	0.01	26.38	0.07	1.12	1.14	1.14
97.00	3.23	3.23	0.00	25.75	0.09	1.13	1.15	1.15
184.00	3.28	3.28	0.01	25.18	0.09	1.16	1.16	1.15
271.00	3.33	3.31	0.02	24.97	0.20	1.17	1.16	1.16
380.00	3.38	3.35	0.03	24.99	0.24	1.18	1.18	1.17
395.00	3.30	3.28	0.02	24.95	0.21	1.20	1.20	1.19
460.00	3.39	3.36	0.03	25.18	0.22	1.16	1.18	1.17
550.00	3.41	3.36	0.05	25.42	0.31	1.13	1.16	1.14
640.00	3.49	3.43	0.06	25.07	0.36	1.09	1.13	1.11
710.00	3.55	3.48	0.07	23.78	0.48	1.09	1.12	1.11
730.00	3.65	3.58	0.07	23.32	0.59	1.09	1.14	1.12
750.00	3.67	3.61	0.07	22.79	0.58	1.07	1.13	1.11

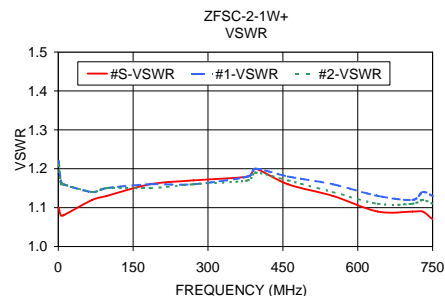
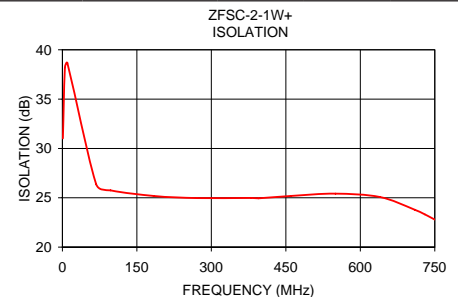
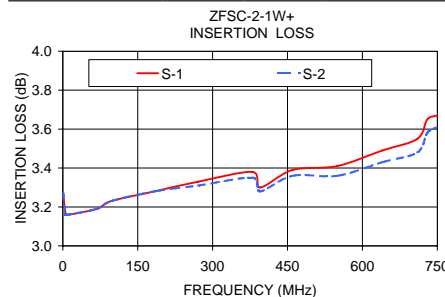

### electrical schematic



For detailed performance specs & shipping online see web site



P.O. Box 350166, Brooklyn, New York 11235-0003 (718) 934-4500 Fax (718) 332-4661 The Design Engineers Search Engine Provides ACTUAL Data Instantly at [minicircuits.com](http://minicircuits.com)

Notes: 1. Performance and quality attributes and conditions not expressly stated in this specification sheet are intended to be excluded and do not form a part of this specification sheet. 2. Electrical specifications and performance data contained herein are based on Mini-Circuit's applicable established test performance criteria and measurement instructions. 3. The parts covered by this specification sheet are subject to Mini-Circuits standard limited warranty and terms and conditions (collectively, "Standard Terms"); Purchasers of this part are entitled to the rights and benefits contained therein. For a full statement of the Standard Terms and the exclusive rights and remedies thereunder, please visit Mini-Circuits' website at [www.minicircuits.com/MCLStore/terms.jsp](http://www.minicircuits.com/MCLStore/terms.jsp).

REV. A  
M108294  
ZFSC-2-1W+  
HY/TD/CP/AM  
090824