

# Power Splitter/Combiner

## ZFRSC-2075

2 Way-0° Resistive 75Ω DC to 2000 MHz



CASE STYLE: K18

### Maximum Ratings

Operating Temperature	-55°C to 100°C
Storage Temperature	-55°C to 100°C
Power Input (as a splitter)	0.75W max.
Internal Dissipation	0.375W max.

Permanent damage may occur if any of these limits are exceeded.

### Coaxial Connections

SUM PORT	3
PORT 1	1
PORT 2	2

### Features

- wideband, DC to 2000 MHz
- low insertion loss, 0.3 dB typ.
- excellent amplitude unbalance, 0.02 dB typ.
- rugged shielded case

### Applications

- laboratory
- test set-ups

Connectors	Model	Price	Qty.
BNC	ZFRSC-2075	\$59.95	(1-9)
BRACKET (OPTION "B")		\$2.50	(1+)

### Electrical Specifications

FREQ. RANGE (MHz)	ISOLATION (dB)			INSERTION LOSS (dB) ABOVE 6.0 dB						PHASE UNBALANCE (Degrees)			AMPLITUDE UNBALANCE (dB)		
	L	M	U	L		M		U		L	M	U	L	M	U
				Typ.	Max.	Typ.	Max.	Typ.	Max.						
$f_L$ - $f_U$	Typ.	Typ.	Typ.	Typ.	Max.	Typ.	Max.	Typ.	Max.	Max.	Max.	Max.	Max.	Max.	Max.
DC-2000	6.2	6.6	7.0	0.1	0.2	0.3	0.6	0.5	1.4	1	2	5	0.1	0.2	0.5

L = low range [DC-100 MHz] M = mid range [100 MHz to  $f_U/2$ ] U = upper range [ $f_U/2$  to  $f_U$ ]

This is a resistive power divider to enable frequency coverage from dc to the highest rated frequency. Since resistive power divider do not provide a high degree of isolation (basically isolation equals the insertion loss between ports), an amplifier such as Mini-Circuits' ZFL series is recommended when high isolation is required. Matched power rating 0.75W, internal load dissipation 0.375W.

### Outline Drawing

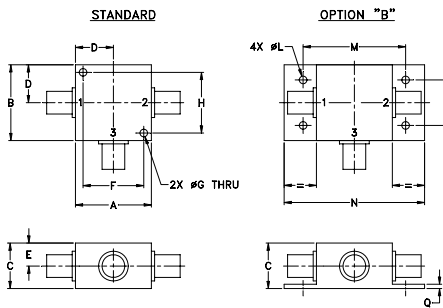

### Outline Dimensions (inch/mm)

A	B	C	D	E	F	G	H
1.25	1.25	.75	.63	.38	1.00	.125	1.000
31.75	31.75	19.05	16.00	9.65	25.40	3.18	25.40

J	K	L	M	N	P	Q	wt
--	--	.125	1.688	2.18	.75	.07	grams
--	--	3.18	42.88	55.37	19.05	1.78	70.0

### Typical Performance Data

Frequency (MHz)	Insertion Loss (dB)		Amplitude Unbalance (dB)	Isolation (dB)	Phase Unbalance (deg.)	VSWR S	VSWR 1	VSWR 2
	S-1	S-2						
0.03	6.06	6.06	0.00	6.06	0.01	1.00	1.00	1.00
10.00	6.03	6.03	0.00	6.03	0.01	1.00	1.00	1.00
28.00	6.04	6.03	0.01	6.03	0.05	1.01	1.01	1.01
46.00	6.03	6.02	0.01	6.03	0.03	1.01	1.01	1.01
73.00	6.03	6.03	0.00	6.03	0.03	1.02	1.02	1.02
100.00	6.04	6.03	0.01	6.03	0.02	1.03	1.03	1.03
310.00	6.06	6.06	0.00	6.06	0.11	1.10	1.11	1.10
590.00	6.15	6.14	0.01	6.15	0.14	1.19	1.21	1.20
820.00	6.32	6.31	0.01	6.30	0.36	1.26	1.28	1.27
900.00	6.37	6.35	0.03	6.34	0.39	1.30	1.32	1.30
980.00	6.41	6.39	0.01	6.37	0.46	1.31	1.34	1.32
1300.00	6.65	6.63	0.01	6.62	0.53	1.21	1.24	1.23
1500.00	6.71	6.71	0.01	6.73	0.70	1.22	1.24	1.22
1700.00	6.63	6.63	0.00	6.70	0.71	1.20	1.21	1.19
2000.00	6.36	6.37	0.01	6.48	0.65	1.26	1.25	1.22

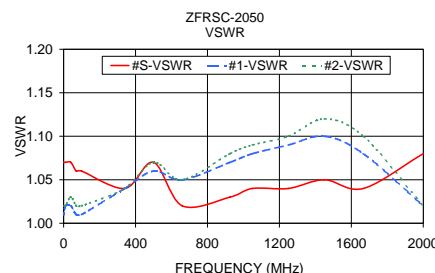
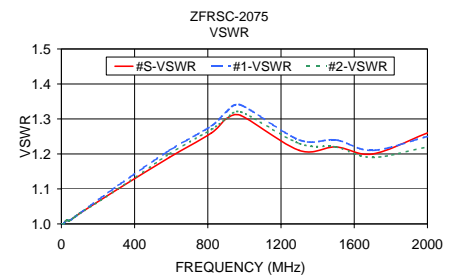
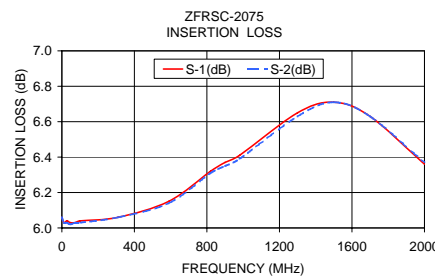

### electrical schematic

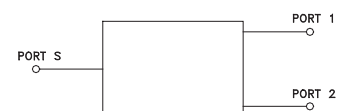

For detailed performance specs & shopping online see web site

P.O. Box 350166, Brooklyn, New York 11235-0003 (718) 934-4500 Fax (718) 332-4661 The Design Engineers Search Engine Provides ACTUAL Data Instantly at [minicircuits.com](http://minicircuits.com)

Notes: 1. Performance and quality attributes and conditions not expressly stated in this specification sheet are intended to be excluded and do not form a part of this specification sheet. 2. Electrical specifications and performance data contained herein are based on Mini-Circuit's applicable established test performance criteria and measurement instructions. 3. The parts covered by this specification sheet are subject to Mini-Circuits standard limited warranty and terms and conditions (collectively, "Standard Terms"); Purchasers of this part are entitled to the rights and benefits contained therein. For a full statement of the Standard Terms and the exclusive rights and remedies thereunder, please visit Mini-Circuits' website at [www.minicircuits.com/MCLStore/terms.jsp](http://www.minicircuits.com/MCLStore/terms.jsp).

REV. OR  
M94666  
ZFRSC-2075  
HY/TD/CP  
090824