

Coaxial Frequency Mixer

Level 7 (LO Power +7 dBm) 10 to 750 MHz

ZFM-1W+
ZFM-1W



SMA version shown
CASE STYLE: K18

Maximum Ratings

Operating Temperature	-55°C to 100°C
Storage Temperature	-55°C to 100°C
RF Power	50mW
IF Current	40mA
Permanent damage may occur if any of these limits are exceeded.	

Coaxial Connections

LO	1
RF	2
IF	3

Features

- low conversion loss, 5.42 dB typ.
- good L-R isolation, 45 dB typ, L-I, 40 dB typ.
- rugged shielded case

Applications

- VHF/UHF
- defense & federal communications
- instrumentation

Connectors	Model	Price	Qty.
BNC	ZFM-1W(+)	\$51.95 ea.	(1-9)
SMA	ZFM-1W-S+	\$56.95 ea.	(1-9)
BRACKET (OPTION "B")		\$2.50	(1+)

+ RoHS compliant in accordance with EU Directive (2002/95/EC)

The +Suffix identifies RoHS Compliance. See our web site for RoHS Compliance methodologies and qualifications.

Outline Drawing

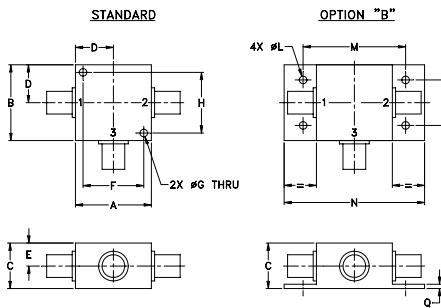

Outline Dimensions (inch/mm)

A	B	C	D	E	F	G	H
1.25	1.25	.75	.63	.38	1.00	.125	1.000
31.75	31.75	19.05	16.00	9.65	25.40	3.18	25.40

J	K	L	M	N	P	Q	wt
--	--	.125	1.688	2.18	.75	.07	grams
--	--	3.18	42.88	55.37	19.05	1.78	70.0

Electrical Specifications

FREQUENCY (MHz)	CONVERSION LOSS (dB)	LO-RF ISOLATION (dB)			LO-IF ISOLATION (dB)				
		L	M	U	L	M	U		
10-750	5.42	50	45	30	45	40	25	27	20

1 dB COMP.: +1 dBm typ. L = low range [f_L to $10 f_L$] M = mid range [$10 f_L$ to $f_U/2$] U = upper range [$f_U/2$ to f_U]
 \bar{X} = Mid-Band m σ = Total Range Max. $m = \text{mid band } [2f_L \text{ to } f_U/2]$

Typical Performance Data

Frequency (MHz)		Conversion Loss (dB)	Isolation L-R (dB)	Isolation L-I (dB)	VSWR RF Port (:1)	VSWR LO Port (:1)
RF	LO	LO +7dBm	LO +7dBm	LO +7dBm	LO +7dBm	LO +7dBm
1.00	31.00	6.42	>67.00	>67.00	1.20	3.31
2.00	32.00	5.97	>67.00	>67.00	1.12	3.09
5.00	35.00	5.50	>67.00	>67.00	1.10	3.15
10.00	40.00	5.66	>67.00	>67.00	1.12	2.99
20.00	50.00	5.60	>67.00	>67.00	1.14	2.99
50.00	80.00	5.60	>67.00	62.28	1.16	2.84
100.00	70.00	5.47	>67.00	55.09	1.20	2.88
130.14	100.14	5.52	57.96	51.55	1.23	2.75
200.00	170.00	5.62	50.48	45.84	1.30	2.74
285.11	255.11	5.47	45.61	40.64	1.35	2.74
362.59	332.59	5.71	42.62	37.34	1.40	2.78
414.25	384.25	5.97	40.09	36.21	1.45	2.78
500.00	470.00	6.14	39.49	33.17	1.48	2.80
543.39	513.39	6.24	37.59	31.35	1.50	2.82
595.04	565.04	6.21	37.44	31.39	1.49	2.85
646.70	616.70	6.16	36.31	33.58	1.51	2.93
672.53	642.53	6.27	36.63	31.60	1.58	2.94
698.36	668.36	6.43	36.64	29.86	1.64	3.03
724.18	694.18	6.68	36.68	28.78	1.72	3.01
750.00	720.00	6.98	35.77	27.45	1.83	3.01

Electrical Schematic

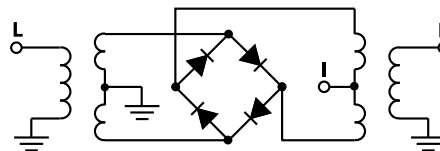

Mini-Circuits
ISO 9001 ISO 14001 AS 9100 CERTIFIED

P.O. Box 350166, Brooklyn, New York 11235-0003 (718) 934-4500 Fax (718) 332-4661 The Design Engineers Search Engine Provides ACTUAL Data Instantly at minicircuits.com

Notes: 1. Performance and quality attributes and conditions not expressly stated in this specification sheet are intended to be excluded and do not form a part of this specification sheet. 2. Electrical specifications and performance data contained herein are based on Mini-Circuit's applicable established test performance criteria and measurement instructions. 3. The parts covered by this specification sheet are subject to Mini-Circuit's standard limited warranty and terms and conditions (collectively, "Standard Terms"); Purchasers of this part are entitled to the rights and benefits contained therein. For a full statement of the Standard Terms and the exclusive rights and remedies thereunder, please visit Mini-Circuit's website at www.minicircuits.com/MCLStore/terms.jsp.

For detailed performance specs & shopping online see web site

REV. B
M108294
ZFM-1W+
DJ/TD/CP
080407
Page 1 of 2

Performance Charts

