

Coaxial Directional Coupler

ZFDC-10-1-75

75Ω

1 to 400 MHz



Maximum Ratings

Operating Temperature	-55°C to 100°C
Storage Temperature	-55°C to 100°C

Permanent damage may occur if any of these limits are exceeded.

Coaxial Connections

INPUT	1
OUTPUT	2
COUPLED	3

Features

- excellent directivity, 44 dB typ.
- up to 4W input power
- rugged shielded case

Applications

- catv
- VHF/HF
- instrumentation

CASE STYLE: K18

Connectors	Model	Price	Qty.
BNC	ZFDC-10-1-75	\$45.95 ea.	(1-9)
BRACKET (OPTION "B")		\$2.50	(1+)

Directional Coupler Electrical Specifications

FREQ. RANGE (MHz)	COUPLING (dB)		MAINLINE LOSS ¹ (dB)						DIRECTIVITY (dB)						VSWR (:1)	POWER INPUT (W)		
	Nom.	Flatness	L		M		U		L		M		U			Typ.	L	MU
			Typ.	Max.	Typ.	Max.	Typ.	Max.	Typ.	Min.	Typ.	Min.	Typ.	Min.				
1-400	10.5±0.5	±0.5	1.0	1.7	1.1	1.5	1.1	1.6	46	30	44	28	34	20	1.3	2.0	4.0	

L = low range [f_L to $10 f_L$] M = mid range [$10 f_L$ to $f_U/2$] U = upper range [$f_U/2$ to f_U]
 1. Mainline loss includes theoretical power loss at coupled port.

Outline Drawing

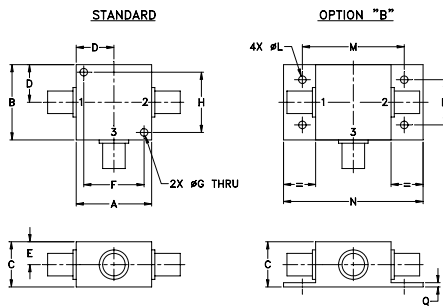

Outline Dimensions (inch/mm)

A	B	C	D	E	F	G	H
1.25	1.25	.75	.63	.38	1.00	.125	1.000
31.75	31.75	19.05	16.00	9.65	25.40	3.18	25.40

J	K	L	M	N	P	Q	wt
--	--	.125	1.688	2.18	.75	.07	grams
--	--	3.18	42.88	55.37	19.05	1.78	70.0

Typical Performance Data

Frequency (MHz)	Mainline Loss (dB) In-Out	Coupling (dB) In-Cpl	Directivity (dB)	Return Loss (dB)		Cpl
				In	Out	
1.00	1.16	10.68	58.99	23.11	17.09	17.35
4.60	0.93	10.48	59.93	33.06	19.71	19.75
8.20	0.90	10.46	57.01	38.55	20.09	20.06
10.00	0.89	10.46	56.81	41.04	20.17	20.11
56.00	0.92	10.48	44.49	39.77	20.01	19.33
128.00	0.94	10.55	36.39	32.77	19.68	17.16
164.00	0.95	10.59	33.96	30.48	19.45	16.03
240.00	0.95	10.70	29.35	26.66	18.97	13.94
320.00	0.96	10.82	25.49	23.65	18.34	12.19
400.00	0.97	10.97	22.28	21.37	17.64	10.84

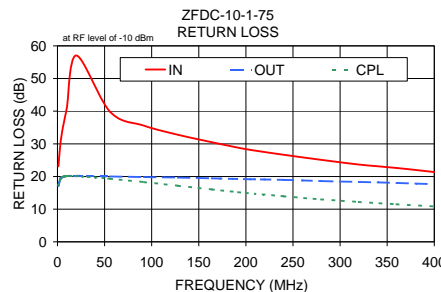
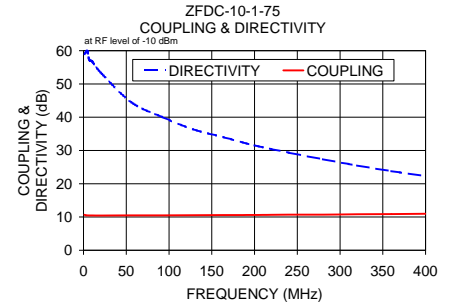
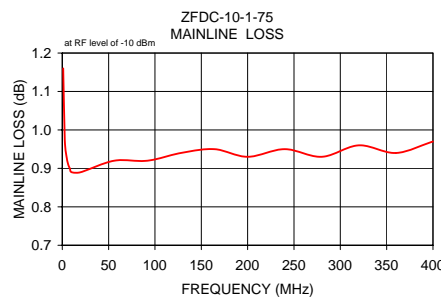

Electrical Schematic

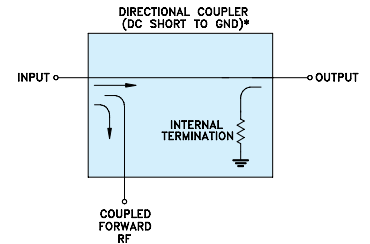

* ELECTRICAL SCHEMATIC IS FOR DIRECTIONAL COUPLER WITH INTERNAL TRANSFORMER(S) THAT ROUTES DC FROM RF PORTS TO GROUND.

For detailed performance specs & shopping online see web site



P.O. Box 350166, Brooklyn, New York 11235-0003 (718) 934-4500 Fax (718) 332-4661 The Design Engineers Search Engine Provides ACTUAL Data Instantly at minicircuits.com

Notes: 1. Performance and quality attributes and conditions not expressly stated in this specification sheet are intended to be excluded and do not form a part of this specification sheet. 2. Electrical specifications and performance data contained herein are based on Mini-Circuit's applicable established test performance criteria and measurement instructions. 3. The parts covered by this specification sheet are subject to Mini-Circuits standard limited warranty and terms and conditions (collectively, "Standard Terms"); Purchasers of this part are entitled to the rights and benefits contained therein. For a full statement of the Standard Terms and the exclusive rights and remedies thereunder, please visit Mini-Circuits' website at www.minicircuits.com/MCLStore/terms.jsp.

REV. A
M119986
ZFDC-10-1-75
WZ/TD/CP/AM
090917