

DC Pass

Bi-Directional Coupler

ZBDC40-1450W+

50Ω Up to 50W 550 to 1450 MHz

Maximum Ratings

Operating Temperature	-55°C to 100°C
Storage Temperature	-55°C to 100°C
DC Current	2.5A

Permanent damage may occur if any of these limits are exceeded.

Coaxial Connections

INPUT	J1
OUTPUT	J2
COUPLED (forward)	J4
COUPLED (reverse)	J3

Outline Drawing

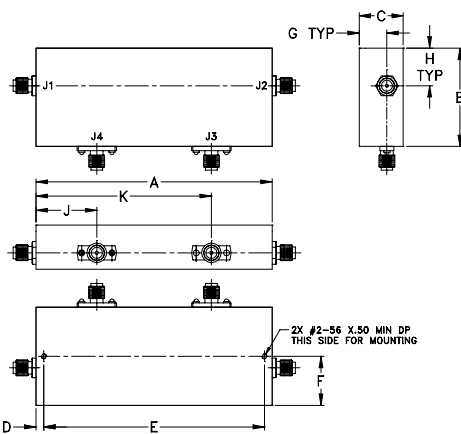

Outline Dimensions (inch/mm)

A	B	C	D	E	F
3.75	1.56	.70	.125	3.500	.780
5.25	39.62	17.78	3.18	88.90	19.81
G	H	J	K	wt	
.44	.60	.97	2.78	grams	
1.18	15.24	24.64	70.61	130.0	

Features

- wide frequency range, 550 to 1450 MHz
- good coupling flatness, ±0.2 dB typ over 800-1000 MHz
- high directivity, 25 dB typ.
- very good return loss, VSWR 1.1:1 typ.
- high power, up to 50W
- very low coupling temperature variation, ±0.1 dB typ.
- DC current through input to output 2.5A Max. at 50watt RF input power.

Applications

- cellular
- lab use

Bi-Directional Coupler Electrical Specifications

FREQ. (MHz)	COUPLING (dB)		MAINLINE LOSS ¹ (dB)		DIRECTIVITY (dB)		VSWR (:1)	POWER INPUT (W)
	Nom.	Flatness	Typ.	Max.	Typ.	Min.		
550-1450	39.9±1.5	±1.5	0.15	0.40	24	18	1.12	50
800-1000	39.9±1.5	±0.40	0.11	0.30	25	20	1.07	50

1. Mainline loss includes theoretical power loss at coupled port.

Typical Performance Data

Frequency (MHz)	Mainline Loss (dB) In-Out	Coupling (dB)		Directivity (dB)		Return Loss (dB)			
		In-Cpl Fwd	Out-Cpl Rev	Out-Cpl Fwd	In-Cpl Rev	In	Out	Cpl Fwd	Cpl Rev
550.00	0.08	41.16	41.16	26.60	27.12	25.73	25.62	28.14	28.21
700.00	0.09	39.77	39.79	25.76	26.97	28.67	28.52	32.06	32.07
800.00	0.09	39.23	39.22	25.13	26.50	32.49	32.19	39.25	37.68
920.00	0.10	38.87	38.87	24.80	26.31	41.24	39.39	35.92	34.36
1000.00	0.10	38.79	38.81	25.22	25.82	64.37	42.67	29.94	29.34
1100.00	0.11	38.91	38.92	25.09	26.37	47.62	41.68	25.51	25.29
1200.00	0.11	39.22	39.25	25.80	26.81	54.95	45.96	22.85	22.72
1300.00	0.12	39.76	39.78	25.84	28.00	42.16	46.08	21.11	21.07
1405.00	0.13	40.62	40.59	26.30	28.46	31.64	32.03	20.07	20.06
1455.00	0.14	41.09	41.09	27.96	30.25	28.42	28.66	19.80	19.83

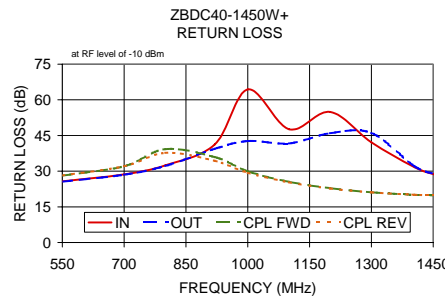
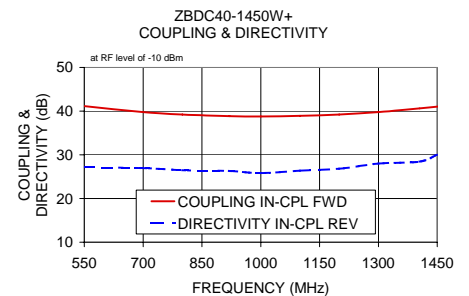
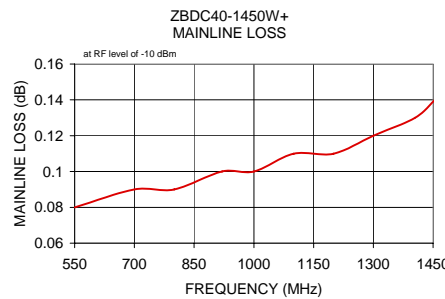

Electrical Schematic

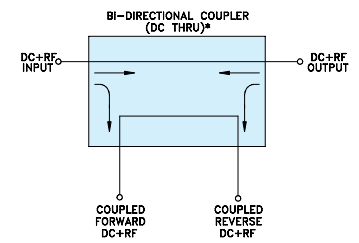

* ELECTRICAL SCHEMATIC IS FOR BI-DIRECTIONAL COUPLER WITHOUT INTERNAL TRANSFORMERS AND RESISTORS.

Mini-Circuits
 ISO 9001 ISO 14001 AS 9100 CERTIFIED
 Provides ACTUAL Data Instantly at minicircuits.com
 IFR/RF MICROWAVE COMPONENTS

For detailed performance specs & shopping online see web site

P.O. Box 350166, Brooklyn, New York 11235-0003 (718) 934-4500 Fax (718) 332-4661 The Design Engineers Search Engine

Notes: 1. Performance and quality attributes and conditions not expressly stated in this specification sheet are intended to be excluded and do not form a part of this specification sheet. 2. Electrical specifications and performance data contained herein are based on Mini-Circuit's applicable established test performance criteria and measurement instructions. 3. The parts covered by this specification sheet are subject to Mini-Circuits standard limited warranty and terms and conditions (collectively, "Standard Terms"); Purchasers of this part are entitled to the rights and benefits contained therein. For a full statement of the Standard Terms and the exclusive rights and remedies thereunder, please visit Mini-Circuits' website at www.minicircuits.com/MCLStore/terms.jsp.

REV. C
 M119986
 ED-12230/1
 ZBDC40-1450W
 HY/LC/CP/AM
 090915