

Coaxial High Isolation Switch

50Ω SPDT, TTL Driver, Absorptive DC to 5000 MHz

ZASWA-2-50DR+



CASE STYLE: CY353

Connectors	Model	Price	Qty.
SMA	ZASWA-2-50DR+	\$89.95	(1-9)

+ RoHS compliant in accordance with EU Directive (2002/95/EC)

The +Suffix has been added in order to identify RoHS Compliance. See our web site for RoHS Compliance methodologies and qualifications.

Maximum Ratings

Operating Temperature	-20°C to 85°C
Storage Temperature	-55°C to 150°C
Input Power	see Table & Note 2
Supply V	see Table

Permanent damage may occur if any of these limits are exceeded.

Coaxial Connections

RF IN	1
RF OUT 1	3
RF OUT 2	6
TTL IN	4
+5V	2
-5V	5

Features

- wideband, DC to 5 GHz
- integral TTL driver
- high isolation, 82 dB typ at 2GHz

Applications

- transmitter receiver isolation
- automated switching networks

Electrical Specifications

FREQ. (MHz)	INSERTION LOSS (dB)								1dB COMPR. (dBm)				IN-OUT ISOLATION (dB)											
	DC-100 MHz		100-1000 MHz		1000-2000 MHz		2000-5000 MHz		DC-100 MHz		100-1000 MHz		1000-2000 MHz		2000-5000 MHz		DC-100 MHz		100-1000 MHz		1000-2000 MHz		2000-5000 MHz	
	f _L	f _U	Typ.	Max.	Typ.	Max.	Typ.	Max.	Typ.	Typ.	Typ.	Typ.	Typ.	Typ.	Typ.	Typ.	Typ.	Min.	Typ.	Min.	Typ.	Min.	Typ.	Min.
DC 5000			1.3	2.0	1.7	2.5	1.8	3.0	3.0	4.5	17	20	20	19	100	80	90	75	82	65	68	46		

Outline Drawing

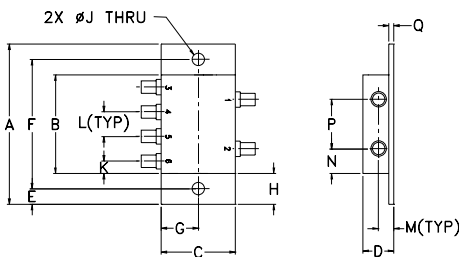

Outline Dimensions (inch/mm)

A	B	C	D	E	F	G	H
3.24	2.00	1.50	.62	.31	2.620	.75	.62
82.30	50.80	38.10	15.75	7.87	66.55	19.05	15.75
J	K	L	M	N	P	Q	wt
.250	.25	.50	.31	.50	1.00	.13	grams
6.35	6.35	12.70	7.87	12.70	25.40	3.30	65.0

Additional Specifications

Low Threshold, V	0 Min., 0.8 Max.
High Threshold, V	2 Min., 5 Max.
Control Current, mA	High V, 5 Max. Low V, 0.2 Max.
Positive Supply, V	+5±0.5/-0.1
Negative Supply, V	-5±0.5/+0.1
Positive Supply Current, mA	22 Typ., 60 Max.
Negative Supply Current, mA	22 Typ., 60 Max.
Video Leakage ¹ , mVp-p	140 Typ.
RF Power Input ²	250mW
VSWR (:1)	
ON, all ports	1.3 Typ.
OFF, Input	1.3 Typ.
OFF, Output	1.3 Typ.
Rise/Fall Time (10%-90%), ns	5 Typ., 15 Max.
Switching Time, 50% of control to 90% RF (Turn-on), ns	10 Typ., 20 Max.
10% RF (Turn-off), ns	10 Typ., 20 Max.

1. Video leakage or break through is defined as leakage of TTL switching signal to RF output ports.
2. Above 20° derate power linearly to zero at 150°C
3. All RF connections must be DC blocked or held at 0V DC.

CONTROL LOGIC

TTL Control Port	RF outputs	
	1	2
HIGH	OFF	ON
LOW	ON	OFF

Electrical Schematic

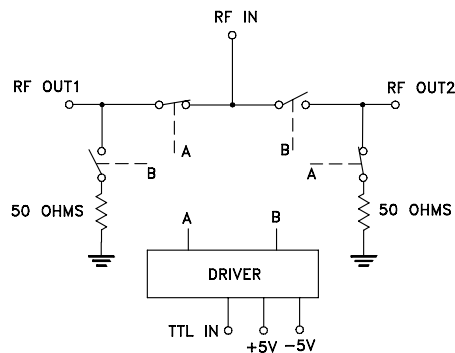

Mini-Circuits
ISO 9001 ISO 14001 AS 9100 CERTIFIED

P.O. Box 350166, Brooklyn, New York 11235-0003 (718) 934-4500 Fax (718) 332-4661 The Design Engineers Search Engine Provides ACTUAL Data Instantly at minicircuits.com

IF/RF MICROWAVE COMPONENTS

For detailed performance specs & shopping online see web site

Notes: 1. Performance and quality attributes and conditions not expressly stated in this specification sheet are intended to be excluded and do not form a part of this specification sheet. 2. Electrical specifications and performance data contained herein are based on Mini-Circuits' applicable established test performance criteria and measurement instructions. 3. The parts covered by this specification sheet are subject to Mini-Circuits standard limited warranty and terms and conditions (collectively, "Standard Terms"); Purchasers of this part are entitled to the rights and benefits contained therein. For a full statement of the Standard Terms and the exclusive rights and remedies thereunder, please visit Mini-Circuits' website at www.minicircuits.com/MCLStore/terms.jsp.

REV. E
M120055
ZASWA-2-50DR+
FL/WP/CP/AM
090112
Page 1 of 2

Typical Performance Data

FREQ. (MHz)	ON INSERTION LOSS (dB) IN-OUT		OFF ISOLATION (dB) IN-OUT		VSWR IN	VSWR ON	VSWR OUT OFF
	\bar{x}	σ	\bar{x}	σ	\bar{x}	\bar{x}	\bar{x}
1.00	0.89	0.00	106.76	16.07	1.22	1.22	1.06
5.00	0.91	0.00	83.79	0.16	1.21	1.21	1.06
7.00	0.92	0.00	108.04	3.89	1.21	1.21	1.06
10.00	0.94	0.00	100.56	4.13	1.20	1.20	1.06
50.00	1.03	0.00	92.67	0.19	1.19	1.19	1.06
70.00	1.04	0.00	92.95	3.93	1.19	1.19	1.06
100.00	1.05	0.00	94.98	2.22	1.19	1.18	1.06
500.00	1.24	0.02	98.65	1.31	1.22	1.16	1.05
700.00	1.31	0.03	95.02	3.53	1.21	1.13	1.05
1000.00	1.39	0.03	100.87	5.77	1.16	1.08	1.05
1500.00	1.50	0.03	93.19	4.35	1.16	1.16	1.05
1750.00	1.58	0.03	89.60	5.94	1.26	1.21	1.06
2000.00	1.70	0.03	81.79	0.85	1.34	1.20	1.07
2500.00	1.82	0.07	73.46	1.48	1.42	1.06	1.08
2750.00	1.89	0.09	74.32	0.48	1.43	1.20	1.09
3000.00	1.99	0.09	70.93	0.22	1.42	1.36	1.10
3500.00	2.25	0.04	59.87	0.47	1.25	1.48	1.10
4000.00	2.41	0.03	63.20	1.11	1.09	1.22	1.11
4500.00	2.57	0.02	71.72	14.06	1.26	1.11	1.13
5000.00	2.86	0.00	60.84	4.95	1.33	1.16	1.19

