

# SPDT RF Switch

50Ω 500-6000 MHz

Absorptive RF Switch with internal driver.  
Single Supply Voltage, +3V to +5V

## Product Features

- High Isolation, 65 dB typ. at 1 GHz
- Low insertion loss, 1.0 dB typ. at 1 GHz
- High IP3, 50 dBm typ. at 1 GHz
- Fast switching, Rise/fall time, 23 ns typ.
- Low current consumption, 12 μA typ.

## Typical Applications

- Automated switching networks
- Cellular/ PCS
- ISM, WCDMA, WiMAX, LTE



## VSWA2-63DR+

CASE STYLE: DG1235  
PRICE: \$0.99 ea. QTY. (100)

+ RoHS compliant in accordance  
with EU Directive (2002/95/EC)

The +Suffix has been added in order to identify RoHS Compliance. See our web site for RoHS Compliance methodologies and qualifications.

## General Description

VSWA2-63DR+ is a high isolation absorptive SPDT switch with integral CMOS driver, operates with single positive supply voltage while consuming, 12μA typical. It has been designed for very wideband operation of 500-6000 MHz for 50Ω systems and yet is usable in 75Ω systems with degraded return loss. This switch is usable over an extended frequencies from 300 kHz to 500 MHz with reflective switch performance. It is packaged in a tiny 4mm x 4mm x 0.9mm package and is rated MSL1 and class 1A ESD.

## Simplified Schematic and Pad Description

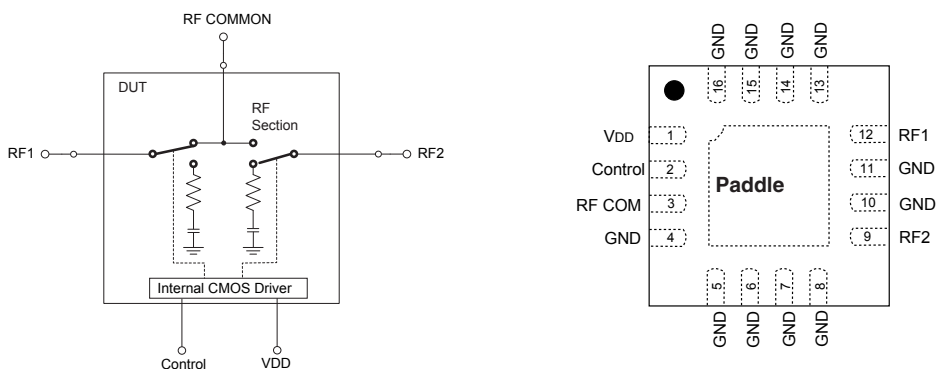

Function	Pad Number	Description
RF COM	3	RF Common/ SUM Port, requires DC block (see Fig. 2)
RF1	12	RF Out #1/In Port #1, requires DC block (see Fig. 2)
RF2	9	RF Out #1/In Port #2, requires DC block (see Fig. 2)
Control	2	CMOS Control IN
VDD	1	Supply Voltage
GND	4,5,6,7,8,10,11 13,14,15,16, paddle	RF Ground

**Mini-Circuits®**  
ISO 9001 ISO 14001 AS 9100 CERTIFIED  
The Design Engineers Search Engine Provides ACTUAL Data Instantly at [minicircuits.com](http://minicircuits.com)  
IF/RF MICROWAVE COMPONENTS

For detailed performance specs  
& shopping online see web site

P.O. Box 350166, Brooklyn, New York 11235-0003 (718) 934-4500 Fax (718) 332-4661

Notes: 1. Performance and quality attributes and conditions not expressly stated in this specification sheet are intended to be excluded and do not form a part of this specification sheet. 2. Electrical specifications and performance data contained herein are based on Mini-Circuit's applicable established test performance criteria and measurement instructions. 3. The parts covered by this specification sheet are subject to Mini-Circuits standard limited warranty and terms and conditions (collectively, "Standard Terms"); Purchasers of this part are entitled to the rights and benefits contained therein. For a full statement of the Standard Terms and the exclusive rights and remedies thereunder, please visit Mini-Circuits' website at [www.minicircuits.com/MCLStore/terms.jsp](http://www.minicircuits.com/MCLStore/terms.jsp).

REV. OR  
M123387  
VSWA2-63DR+  
ED-12806A  
091007  
Page 1 of 5

RF Electrical Specifications<sup>(1)</sup>, 500 - 6000 MHz, T<sub>AMB</sub>=25°C, V<sub>DD</sub>= +3V to +5V

Parameter	Condition (MHz)	Min.	Typ.	Max.	Units
Frequency Range		500		6000	MHz
Insertion Loss <sup>(2)</sup>	0.3 to 500		1.0		dB
	500 to 2000		1.0	1.3	
	2000 to 3000		1.2	1.5	
	3000 to 4000		1.2	1.5	
	4000 to 6000		1.5	1.9	
Isolation between Common port and RF1/RF2 Ports	0.3 to 500		60		dB
	500 to 2000	56	70		
	2000 to 3000	50	60		
	3000 to 4000	45	54		
	4000 to 6000	38	44		
Isolation between RF1 and RF2 ports	0.3 to 500		60		dB
	500 to 1000	50	60		
	1000 to 2000	45	54		
	2000 to 3000	40	46		
	3000 to 4000	38	43		
	4000 to 6000	34	40		
Return Loss (ON STATE)	0.3 to 500		20		dB
	500 to 2000		20		
	2000 to 3000		15		
	3000 to 4000		15		
	4000 to 6000		16		
Return Loss @ RF1/RF2 ports (OFF STATE)	500 to 2000		13		dB
	2000 to 3000		13		
	3000 to 4000		14		
	4000 to 6000		14		
Input IP3	V <sub>DD</sub> =3V	500 to 2000		46	dBm
		2000 to 6000		40	
	V <sub>DD</sub> =5V	500 to 2000		50	
		2000 to 6000		44	
Input Compression <sup>(3)</sup>	1dB, V <sub>DD</sub> =3V	500 to 2000		24	dBm
		2000 to 6000		22	
	0.2 dB, V <sub>DD</sub> =5V	500 to 2000		30	
		2000 to 6000		27	

## DC Electrical Specifications

Parameter	Min.	Typ.	Max.	Units
VDD, Supply Voltage	3		5	V
Supply Current (V <sub>DD</sub> = 5V) <sup>(4)</sup>		12		μA
Control Voltage Low	0		0.5	V
Control Voltage High <sup>(5)</sup>	2.7		V <sub>DD</sub>	V
Control Current		5		μA

## Notes:

1. Tested on Mini-Circuit's test board TB-407+, using Agilent's N5230A network analyzer (see Characterization Test Circuit, Fig.1).
2. Insertion loss values are deembedded from test board loss.
3. Do not exceed RF input power as shown in Absolute Maximum Rating table.
4. Supply current increases with switching repetition rate. See graph.
5. CMOS interface. Latch up condition may occur when logic high signal is applied prior to power supply.

## Switching Specifications

Parameter	Min.	Typ.	Max.	Units
Rise/Fall Time (10 to 90% or 90 to 10% RF)		23		nSec
Switching Time, 50% CTRL to 90/10% RF		35		nSec
Video Feedthrough, (control 0 to 3V, freq.=500 KHz, V <sub>DD</sub> =5V)		25		mV <sub>P-P</sub>



P.O. Box 350166, Brooklyn, New York 11235-0003 (718) 934-4500 Fax (718) 332-4661 The Design Engineers Search Engine  Provides ACTUAL Data Instantly at [minicircuits.com](http://minicircuits.com)

IF/RF MICROWAVE COMPONENTS

For detailed performance specs & shopping online see web site

Notes: 1. Performance and quality attributes and conditions not expressly stated in this specification sheet are intended to be excluded and do not form a part of this specification sheet. 2. Electrical specifications and performance data contained herein are based on Mini-Circuit's applicable established test performance criteria and measurement instructions. 3. The parts covered by this specification sheet are subject to Mini-Circuits standard limited warranty and terms and conditions (collectively, "Standard Terms"); Purchasers of this part are entitled to the rights and benefits contained therein. For a full statement of the Standard Terms and the exclusive rights and remedies thereunder, please visit Mini-Circuits' website at [www.minicircuits.com/MCLStore/terms.jsp](http://www.minicircuits.com/MCLStore/terms.jsp).

**Absolute Maximum Ratings<sup>(6)</sup>**

Parameter	Ratings
Operating Temperature	-40°C to +85°C
Storage Temperature	-65°C to 150°C
V <sub>DD</sub> , Supply Voltage	2.7 to 5.5V
Voltage Control	-0.2V Min. V <sub>DD</sub> Max.
RF input power	1Watt
Dissipated Power at 25°C	350mW

6. Operation of this device above any of these conditions may cause permanent damage.

**Truth Table** (State of control voltage selects the desired switch state)

State of Control Voltage	RF Common to	
	RF1	RF2
Low	ON	OFF
High	OFF	ON

ON- low insertion loss state OFF- Isolation State

**Characterization Test Circuit**

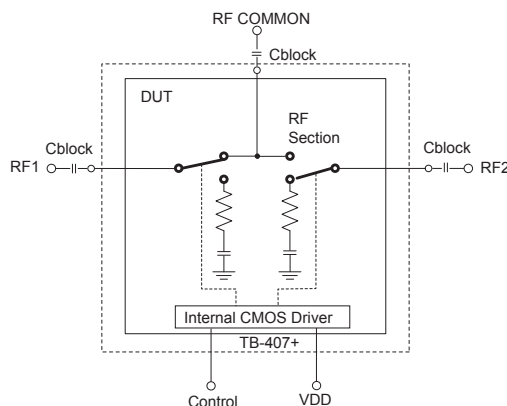

Figure 1: Block Diagram Of Test Circuit Used For Characterization. (DUT soldered on Mini-Circuit's TB-407+)

**Test Equipment:**

**For Insertion loss, Isolation, Return loss and DC current:**

Agilent's N5230A Network Analyzer , E3631A power supply. Cblock: Internal to network Analyzer.

**For Switching Time and DC Current:**

Agilent's 54832B oscilloscope, 81110A pulse generator and E3631 A power supply. Cblock: Mini-Circuits BLK-18-S+

**For Input IP3:**

Mini-Circuits DC blocks: BLK-18-S+ on all ports, Agilent's E8257D signal generators, 437B power meter, N9020A Signal analyzer and E3631 A power supply.

**For Compression:**

Mini-Circuits DC blocks: BLK-18-S+ on all ports. ZVE-8G and ZHL-42W amplifier as driver amplifier at RF Common. Agilent's N5230A Network Analyzer, E3631A power supply

**Conditions:**

V<sub>DD</sub> = +3 and +5V, Control= 0 and 3V.

**For Insertion loss, isolation and return loss:** Pin=0 dBm

**For Input IP3:** Pin=-5dBm/tone.

**For Switching time:** RF frequency: 500 MHz at 0 dBm, Control Frequency: 500 KHz and 0 and +3V.

**Product Marking**

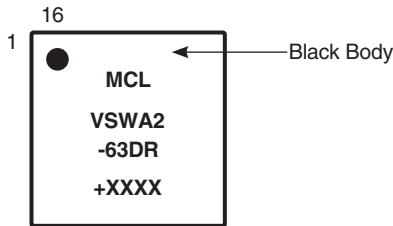

**Additional Detailed Technical Information**

Additional information is available on our web site. To access this information enter the model number on our web site home page.

**Performance data, graphs**

**Case Style: DG1235**

Plastic, finish: matte tin

**Tape & Reel: F87**

**Suggested Layout for PCB Design: PL-278**

**Evaluation Board: TB-486+**

**Environmental Ratings: ENV41**

**Recommended Application Circuit**

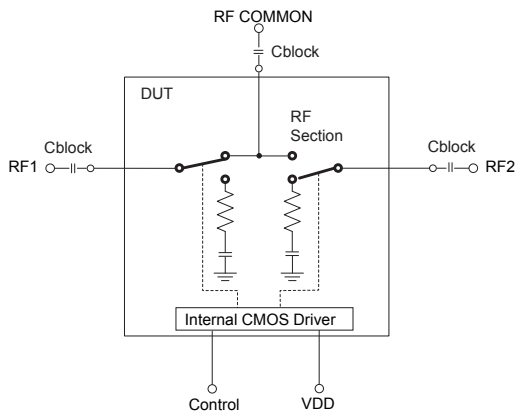

Fig. 2: Evaluation board includes case, connectors and components soldered to PCB.

Frequency (MHz)	Cblock (Suggested value)
0.3-500	0.1µF
500-6000	47pF

Cblock should be free of resonance over frequency of operation.

**ESD Rating**

Human Body Model (HBM): Class 1A (250 to < 500V) in accordance with JESD22-A114

Machine Model (MM): Class A (Passes 50V) in accordance with JESD22-A115

**MSL Rating**

Moisture Sensitivity: MSL1 in accordance with IPC/JEDEC J-STD-020D

**MSL Test Flow Chart**

