

Xtra Long Life 100 million cycles

USB RF-SPDT Switch Matrix

USB-3SPDT-A18

50Ω DC to 18GHz

The Big Deal

- Capable of 100 million cycles
- Wide frequency (DC to 18GHz)
- High power, 10W
- 3 SPDT electromechanical, absorptive, RF switches (Isolation 85 dB typ.) configurable into a SP4T switch
- USB HID device, includes control software with an API DLL com object compatible with 32/64 Bit operating systems



Case Style: LM1625

Installation CD



Product Overview

Mini-Circuits' USB-3SPDT-A18 is a general purpose USB controlled RF switch matrix containing three electro-mechanical SPDT, absorptive fail-safe RF switches constructed in break-before-make configuration and powered by +24V_{DC} with a switching time of 25 mSec typical. The three switches can be set up as: three independent SPDT switches, one SPDT and one SP3T switch, a single SP4T switch, or other configurations (see page 5 for details). The RF switches can be operated in all these configurations remotely using the supplied GUI program, or programmed by the user using the included API DLL com object. The RF switches operate over a wide frequency band from DC to 18GHz, have low insertion loss (0.2 dB typical) and high isolation (85dB typical) making the switch box perfectly suitable for a wide variety of RF applications.

The USB-3SPDT-A18 is constructed in a metal case (size of 4.5" X 6.0" X 2.25") with 9 SMA(F) connectors (COM, 1, 2 for each switch), a 2.1mm DC socket, and a USB type B port. The model is supplied along with a CD containing a graphical user interface program featuring an API DLL com object. Also included is a 2.7ft. USB cable, 2 SMA Male/ SMA Male coaxial semiflex cables for configuring the switch matrix, and a power adapter suitable for US, EU and other power systems, see page 6 for details. Longer USB cables and a mounting bracket are available as additional accessories.

Key Features

Feature	Advantages
USB HID (Human Interface Device)	Plug-and-Play (no need to install a driver for the device).
RF SPDT Electromechanical switch	Wideband (DC to 18GHz) with low insertion loss (0.2 dB typ.), very high isolation (85dB typ.), and high power rating (10W cold switching)
24V _{DC} Operating voltage	The USB-3SPDT-A18 requires 24V/750mA to power the RF switches, supplied from the included power adapter.
32/64 Bit operating systems	Compatible with Windows® and Linux® operating systems using 32 and 64 bit architecture.
Software CD, USB cable, 24V _{DC} Power adapter, and RF cables included	A CD containing a programming manual for Linux® and Windows® operating systems (32 and 64 bit systems) and a Windows® GUI program containing an API DLL com object is included with the USB-3SPDT-A18. A 2.7ft. USB cable, a set of two coaxial semiflex RF cables, and a power adapter suitable for US, EU and other power systems are also included.



Xtra Long Life 100 million cycles

USB RF-SPDT Switch Matrix

USB-3SPDT-A18

50Ω DC to 18GHz

Features

- Capable of 100 million cycles
- Three DC to 18GHz SPDT absorptive fail-safe RF switches in break-before-make configuration
- Configurable into SP4T or SP3T switches
- Electromechanical switching (Isolation 85 dB typ.)
- High power handling, 10W
- Greatly simplifies complex switching and timing setups
- Easy installation and operation
- Compatible with 32/64-bit Windows® or Linux® operating systems, as well as LabVIEW®, Delphi®, C++, C#, Visual Basic®, and .NET software¹
- Friendly Windows® Graphical User Interface
- Mounting bracket (Optional)
- protected by US Patents 5,272,458; 6,414,577; 6,650,210; 7,633,361 and 7,843,289

Applications

- Lab
- Test equipment
- Control systems
- Switching a device in and out of a signal path



Case Style: LM1625

Installation CD

Model No.	Description	Price	Qty.
USB-3SPDT-A18	USB RF SPDT Switch	\$980.00 ea.	(1-9)
Included Accessories			
AC/DC-24-3W1	AC/DC 24V Adapter (see Ordering Information)		1
CBL-3W1-XX	AC Power Cord (see Ordering Information)		1
USB-CBL-AB-3+	2.7 ft USB cable		1
141U-4SM+	4 in RF cable		2
RFSW-CD	Installation CD		1

RoHS Compliant
See our web site for RoHS Compliance methodologies and qualifications

Mini-Circuits RF Switch Control Program for USB RF Switch Matrix

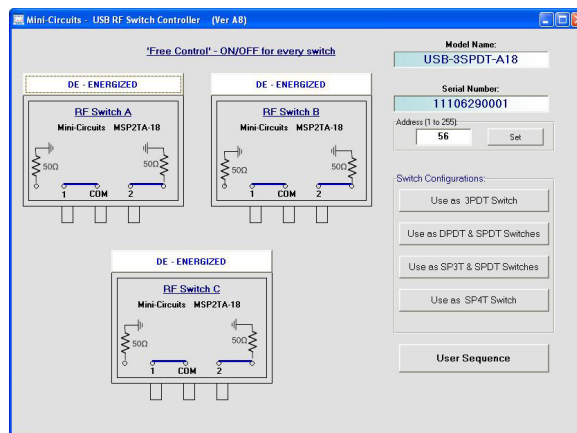

¹ Windows and Visual Basic are registered trademarks of Microsoft Corporation. Linux is a registered trademark of Linus Torvalds. LabVIEW is a registered trademark of National Instruments Corp. Delphi is a registered trademark of Codegear LLC. Neither Mini-Circuits nor the Mini-Circuits USB-3SPDT-A18 Switch are affiliated with or endorsed by the owners of the above referenced trademarks.

Mini-Circuits and the Mini-Circuits logo are registered trademarks of Scientific Components Corporation.

Electrical Specifications

Parameter	Port	Conditions	Min.	Typ.	Max.	Units
Rated Voltage ²	24V _{DC} IN	provided via external power adapter	23	24	25	V
	USB Port	-	-	5	-	
Rated Current	24V _{DC} IN	All switches in COM->2 position	-	580	800	mA
		All switches in COM->1 position	-	65	90	
	USB Port	All switches in COM->2 position	-	65	90	
		All switches in COM->1 position	-	50	80	
Switching Time		-	-	25	-	mS
Life (per switch) ³		@ 100 mW (hot switching) ⁴	10	-	-	million switching cycles
		@ 1 W (hot switching) ⁴	-	3	-	
RF Power (cold switching) ⁵		-	-	-	10	W
RF Power (hot switching) ⁵		-	-	-	1	
RF VSWR		DC to 1 GHz	-	1.05	1.10	:1
		1 GHz to 8 GHz	-	1.20	1.30	
		8 GHz to 12 GHz	-	1.20	1.35	
		12 GHz to 18 GHz	-	1.25	1.40	
RF Insertion Loss (per switch)		DC to 1 GHz	-	0.10	0.15	dB
		1 GHz to 8 GHz	-	0.15	0.30	
		8 GHz to 12 GHz	-	0.25	0.40	
		12 GHz to 18 GHz	-	0.30	0.50	
RF Isolation (per switch)		DC to 1 GHz	85	100	-	dB
		1 GHz to 8 GHz	75	90	-	
		8 GHz to 12 GHz	70	80	-	
		12 GHz to 18 GHz	60	66	-	
RF Insertion Loss (configured as SP3T or SP4T - see page 5 for details)		DC to 1 GHz	-	0.20	-	dB
		1 GHz to 8 GHz	-	0.40	-	
		8 GHz to 12 GHz	-	0.70	-	
		12 GHz to 18 GHz	-	0.90	-	

² Power On Sequence. Connect the 24V power, followed by the USB control before turning on the Switch Matrix.

³ Capable of up to 100 million cycles with proper maintenance, contact Mini-Circuits.

⁴ Exceeding these limits will result in reduced life.

⁵ Power handling is specified with RF applied to the COM port and output load connected to either 1 or 2 of the respective switch.

Minimum System Requirements

Interface	USB HID
Host operating system	32 Bit operating system: Windows 98®, Windows XP®, Windows Vista®, Windows 7® 64 Bit operating system: Windows Vista®, Windows 7® Linux® support: 32/64 Bit operating system
Hardware	Pentium® II or better

Absolute Maximum Ratings

Operating Temperature	0°C to 40°C
Storage Temperature	-15°C to 45°C
DC Voltage max.	26V
RF power (at COM port of any switch)	10W
RF power (at 1 and 2 of any switch)	1W

Permanent damage may occur if any of these limits are exceeded.

Block Diagram

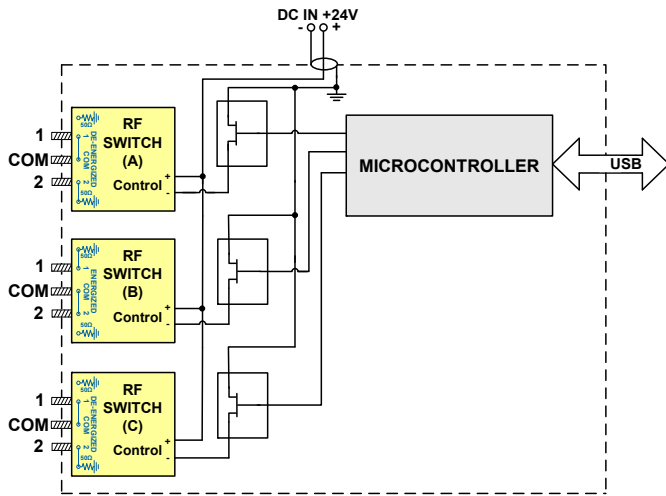

Connections

24V _{DC} IN	(2.1 mm center positive DC Socket)
RF Switch A (1, COM, 2)	(SMA female)
RF Switch B (1, COM, 2)	(SMA female)
RF Switch C (1, COM, 2)	(SMA female)
USB	(USB type B receptacle)

Outline Drawing (LM1625)

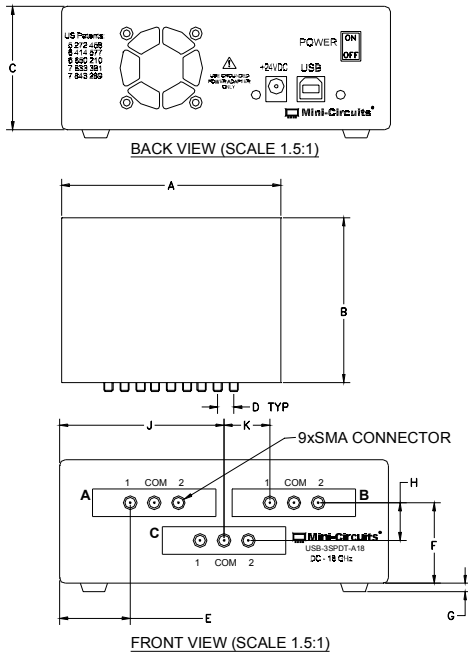

BRACKET OPTION, One set of 2 each

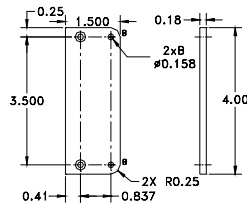

TOLERANCE: ±.005

INSTRUCTION FOR MOUNTING BRACKETS:

TOOL REQUIRED : PHILIPS HEAD SCREW DRIVER

STEP 1: REMOVE RUBBER FEET FROM THE BOTTOM OF UNIT.

DO NOT DISCARD THE FASTENERS .

STEP 2: MOUNT THE BRACKETS WITH THE FASTENERS REMOVED IN STEP 1, USING THE COUNTER BORE HOLES IN BRACKET.

Outline Dimensions (inch mm)

A	B	C	D	E	F	G	H	J	K	wt
6.00	4.50	2.25	.440	1.29	1.47	.28	1.670	3.00	.835	grams
152.4	114.3	57.2	11.18	32.8	37.3	7.1	42.4	76.2	21.2	1075

Configuration options

- Power handling is specified with RF applied to the COM port and output load connected to either 1 or 2 of the respective switch.
- When connecting a coaxial semiflex cable, tighten connectors alternately using an 8in/lb torque wrench to insure proper contact at each end.

Config. A

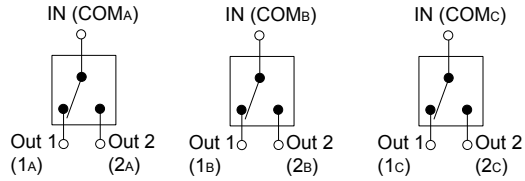
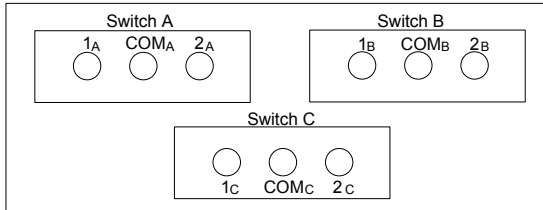

SPDT: Switch A, B or C Logic
 IN ↔ Out1 : 0
 IN ↔ Out2 : 1
 Switches move independently.

DPDT: Switch A & B Logic
 IN ↔ Out1 : 0, 0
 IN ↔ Out2 : 1, 1
 Switches A&B move together as one, switch C is separate.

3PDT: Switch A, B & C Logic
 IN ↔ Out1 : 0, 0, 0
 IN ↔ Out2 : 1, 1, 1
 All three switches move together as one.

Config. B

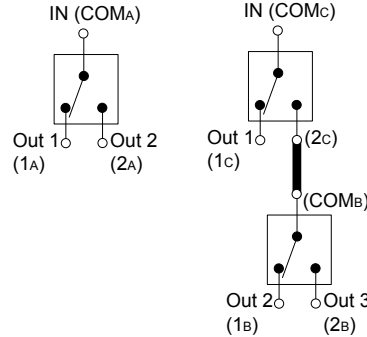
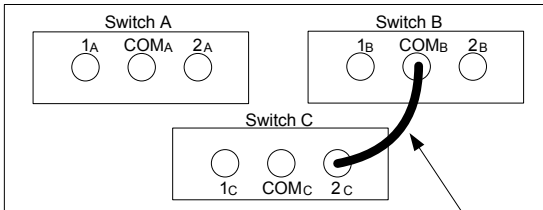

SPDT: Switch A Logic
 IN ↔ Out1 : 0
 IN ↔ Out2 : 1

SP3T:
 Switch B & C Logic
 IN ↔ Out1 : ∅, 0
 IN ↔ Out2 : 1, 0
 IN ↔ Out3 : 1, 1
 Switches B & C move together as one, switch A is separate

4 inch coaxial, semiflex
 SMA(M)-SMA(M) RF cable
MCL P/N: 141U-4SM+

Config. C

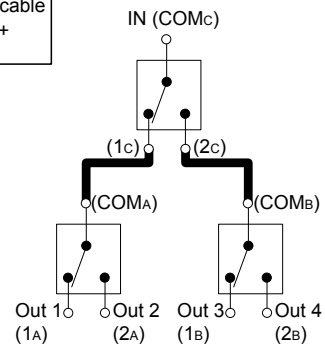
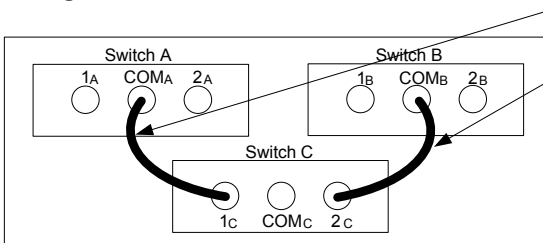

SP4T:
 Switch A, B & C Logic
 IN ↔ Out1 : 0, ∅, 0
 IN ↔ Out2 : 1, ∅, 0
 IN ↔ Out3 : ∅, 0, 1
 IN ↔ Out4 : ∅, 1, 1
 All three switches move together as one.

Ordering, Pricing & Availability Information see our web site

Model	Description
USB-3SPDT-A18	USB RF SPDT Switch Matrix

Included Accessories	Description
AC/DC-24-3W1	AC/DC 24V Power Adapter
CBL-3W1-XX	AC Power Cord (<i>Select one power cord from below with each USB Switch Matrix box</i>)
RFSW-CD	Installation CD
USB-CBL-AB-3+	2.7ft. USB cable
141U-4SM+ ⁶	4 inch coaxial, SMA Male RF semiflex cable (qty 2)

AC Power Cords	Description
CBL-3W1-US	US Power Cord
CBL-3W1-EU	EU Power Cord
CBL-3W1-UK	UK Power Cord
CBL-3W1-AU	AU Power Cord
CBL-3W1-IL	IL Power Cord

Optional Accessories	Description
USB-CBL-AB-3+ (Spare)	2.7 ft (0.8 m) USB cable
USB-CBL-AB-7+	6.8 ft (2.1 m) USB cable
USB-CBL-AB-11+	11 ft (3.4 m) USB cable
BKT-272-08+	Bracket (One set of 2 each)

⁶ RF cables used for additional configurations only, see page 5 for details.

Additional Notes

- A. Performance and quality attributes and conditions not expressly stated in this specification document are intended to be excluded and do not form a part of this specification document.
- B. Electrical specifications and performance data contained in this specification document are based on Mini-Circuit's applicable established test performance criteria and measurement instructions.
- C. The parts covered by this specification document are subject to Mini-Circuits standard limited warranty and terms and conditions (collectively, "Standard Terms"); Purchasers of this part are entitled to the rights and benefits contained therein. For a full statement of the Standard Terms and the exclusive rights and remedies thereunder, please visit Mini-Circuits' website at www.minicircuits.com/MCLStore/terms.jsp