

Wideband, Microwave, Shutdown Monolithic Amplifier

TSS-183A+

50Ω 5 to 18 GHz

The Big Deal

- Surface Mount Amplifier up to 18 GHz
- Integrated matching, DC Blocks and bias circuits
- Shutdown feature, with excellent switching time performance



CASE STYLE: DQ849

Product Overview

The TSS-183A+ is a surface mount, MMIC amplifier with shutdown feature fabricated using InGaAs PHEMT technology and is a fully integrated gain block up to 18 GHz. It is packaged in Mini-Circuits industry standard 3x3 mm MCLP package, which provides excellent RF and thermal performance. The TSS-183A+ integrates the entire matching network with the majority of the bias circuit inside the package, reducing the need for complicated external circuits. This approach makes the TSS-183A+ extremely flexible and enables simple, straightforward use.

Key Features

Feature	Advantages
Wideband, 5 to 18 GHz	Broad frequency range supports a wide array of applications from microwave radio and radar , to military communications and countermeasures.
Excellent Gain Flatness	Typical ± 0.9 dB gain flatness across the entire frequency range minimizes the need for external equalizer networks making it a great fit for instrumentation and EW applications.
High Isolation	With reverse isolation of 36 dB, the TSS-183A+ is an excellent choice for buffering broadband circuits. It is an ideal LO driver amplifier and provides designers system flexibility and margin when integrating cascaded RF components.
Shutdown feature	Allow users to turn on and off the amplifier with pulsed signals while keeping the power supply at constant voltage.
Small size	3x3 mm, 8-lead MCLP package
Integrated DC Blocks & Bias-Tee	Saver motherboard space and minimizes overall cost. Very user friendly.



Wideband, Microwave, Shutdown Monolithic Amplifier

5-18 GHz

Product Features

- Fast shutdown, 29 nS
- Gain, 13.6 dB typ. & Flatness, ± 0.9 dB
- Output Power, up to +17.9 dBm typ.
- Excellent isolation, 36 dB typ.
- Positive Supply Voltage, 5.0V
- Integrated DC blocks, Bias-Tee & Microwave bypass capacitor
- Unconditionally Stable
- Aqueous washable; 3mm x 3mm SMT package



TSS-183A+

CASE STYLE: DQ849

+RoHS Compliant

The +Suffix identifies RoHS Compliance. See our web site for RoHS Compliance methodologies and qualifications

Typical Applications

- Military EW and Radar
- DBS
- Wideband Isolation amplifier
- Microwave point-to-point radios
- Satellite systems

General Description

The TSS-183A+ is a surface mount, MMIC amplifier with shut-down feature fabricated using InGaAs PHEMT technology and is a fully integrated gain block up to 18 GHz. It is packaged in Mini-Circuits industry standard 3x3 mm MCLP package, which provides excellent RF and thermal performance and MSL-1. The TSS-183A+ integrates the entire matching network with the majority of the bias circuit inside the package, reducing the need for complicated external circuits. This approach makes the TSS-183A+ extremely flexible and enables simple, straightforward use.

simplified schematic and pad description

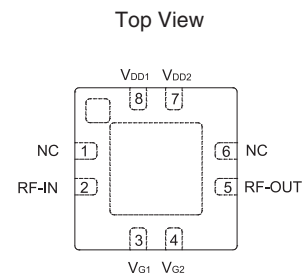
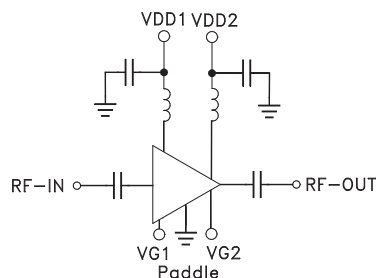

Function	Pad Number	Description (See Application Circuit, Fig. 1)
RF-IN	2	RF input pad
RF-OUT	5	RF output pad
V _{DD1} & V _{DD2}	7,8	DC power supply (V _{DD}). Two pads are connected per Figure 1.
GND	Paddle	Connected to ground.
V _{G1} & V _{G2}	3,4	Control voltage for shutdown(VG). Two pads are connected per Figure 1.
NC	1,6	No internal connection. Recommended usage per PCB layer PL-588

Electrical Specifications⁽¹⁾ at 25°C, Z_o=50Ω, and V_{DD}=5V unless otherwise noted.

Parameter	Condition (GHz)	Amplifier-ON			Amplifier-OFF	Units
		Min.	Typ.	Max.	Typ.	
Frequency Range		5		18	5-18	GHz
Noise Figure	5		7.4		—	dB
	8		4.1		—	
	10		4.4		—	
	12		4.6		—	
	14		5.0		—	
Gain	5	—	13.5	—	-27	dB
	8	12	14.9	—	-19	
	10	12	14.2	—	-18	
	12	—	13.6	—	-17	
	14	—	13.4	—	-17	
18	10.4	13.1	—	-18		
Gain Flatness	5-18		±0.9		—	dB
Reversed Isolation	5-18		36		22	dB
Input Return Loss	5		12		6	dB
	8		36		3	
	10		16		3	
	12		13		4	
	14		16		5	
Output Return Loss	5		9		6	dB
	8		14		4	
	10		18		4	
	12		14		2	
	14		13		2	
Output Power @ 1dB compression AMP-ON	5	—	17.2	—	—	dBm
	8	—	18.5	—	—	
	10	16.0	17.9	—	—	
	12	—	17.8	—	—	
	14	—	18.7	—	—	
Output IP3 (P _{out} =+9dBm/tone)	5		33.7		—	dBm
	8		30.0		—	
	10		28.9		—	
	12		27.8		—	
	14		26.6		—	
18		27.4		—		
Device Operating Voltage (V _{DD})		4.8	5.0	5.2	5.0	V
Device Operating Current (I _d)			145	166	0.3	mA
Control Voltage (V _G)			0		-5	V
DC Current (I _d) Variation Vs. Temperature ²			29.4		—	μA/°C
DC Current (I _d) Variation Vs. Voltage			0.0021		—	mA/mV
Thermal Resistance			61			°C/W

¹ Measured on Mini-Circuits Characterization test board TB-969+. See Characterization Test Circuit (Fig. 1)

² (Current at 85°C - Current at -45°C)/130)

Absolute Maximum Ratings³

Parameter	Ratings
Operating Temperature (ground lead)	-40°C to 85°C
Storage Temperature	-55°C to 100°C
Total Power Dissipation	0.98 W
Input Power	20 dBm
DC Voltage V _{DD} ⁴ (Pad 7, 8)	5.5V
DC Voltage V _G ⁵ (Pad 3, 4)	-15V
DC Voltage RF-IN & RF-OUT (Pad 2 & 5)	10V

³ Permanent damage may occur if these limits are exceeded.

⁴ Measured by keeping V_G=0V. V_{DD1} & V_{DD2} pads are connected per Figure 1.

⁵ Measured by keeping V_{DD}=5V. V_{G1} & V_{G2} pads are connected per Figure 1.

Control Voltage (V_G) Fig. 1

	Min.	Typ.	Max.	Units
Amplifier-ON	-0.2	—	0	V
Amplifier-OFF	-5	—	-4	V

Switching Specifications (Rise/Fall Time)

Parameter		Min.	Typ.	Max.	Units
Amplifier ON to Bypass	OFF TIME (50% Control to 10% RF)	—	29	—	ns
	FALL TIME (90 to 10% RF)	—	14	—	
Amplifier Bypass to ON	ON TIME (50% Control to 90% RF)	—	226	—	ns
	RISE TIME (10% to 90% RF)	—	163	—	
Control Voltage Leakage		—	12	—	mV

Characterization Test Circuit / Recommended Application Circuit

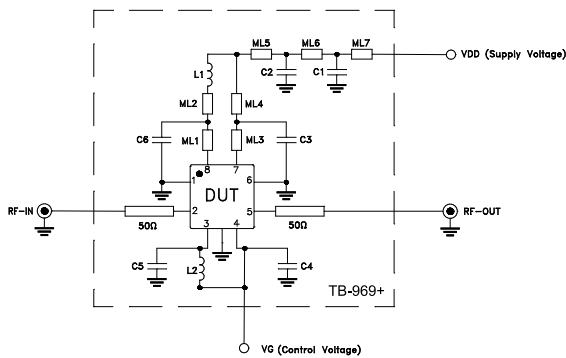

Component	P/N	SUPPLIER	Value	Size
C1	GRM1555C1H5R6CA01D	Murata	5.6pF	0402
C2	GRM1555C1H180JA01D	Murata	18pF	0402
C3 – C5	GRM1555C1H102JA01D	Murata	0.001uF	0402
C6	GRM155R71C104KA88D	Murata	0.1uF	0402
L1 , L2	0805CS-030XJLC	Coilcraft	3.3nH	0805

ML1 to ML7 are short microstrip lines. Refer to PL-588

Fig 1. Block diagram of Test Circuit used for characterization. (DUT soldered on Mini-Circuits Characterization test board TB-969+) Gain, Return loss, Output power at 1dB compression (P1dB) , output IP3 (OIP3) and noise figure measured using Agilent’s N5242A PNA-X microwave network analyzer.

Conditions:

1. Gain and Return loss: Pin= -25dBm
2. Output IP3 (OIP3): Two tones, spaced 1 MHz apart, +9dBm/tone at output.
3. Switching Time: Pin=7dBm at 5.2 GHz. V_G=Pulse signal at 1 KHz, -5V, with offset=-2.5V, 50% duty cycle. V_{DD}=5V.

Product Marking

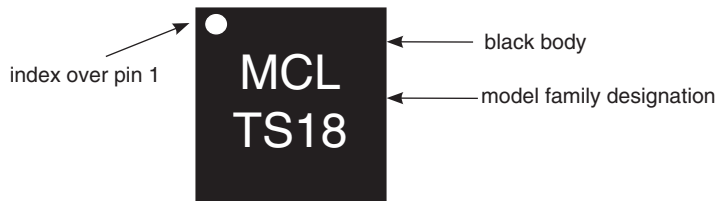

Marking may contain other features or characters for internal lot control

Additional Detailed Technical Information	
<i>additional information is available on our dash board. To access this information click here</i>	
Performance Data	Data Table
	Swept Graphs
	S-Parameter (S2P Files) Data Set (.zip file)
Case Style	DQ849 <i>Plastic package, exposed paddle, lead finish: matte-tin</i>
Tape & Reel Standard quantities available on reel	F104 <i>7" reels with 10, 20, 50, 100, 200, 500, 1000 or 2000 devices.</i>
Suggested Layout for PCB Design	PL-588
Evaluation Board	TB-969+
Environmental Ratings	ENV08T1

ESD Rating

Human Body Model (HBM): 1A (250 to <500V) in accordance with ANSI/ESD STM 5.1 - 2001

MSL Test Flow Chart

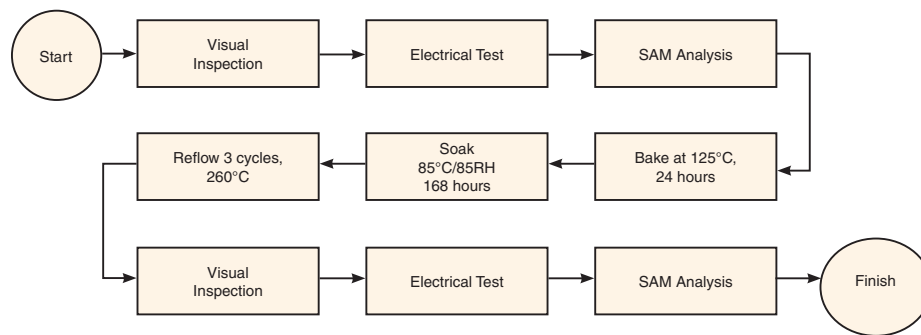

Additional Notes

- Performance and quality attributes and conditions not expressly stated in this specification document are intended to be excluded and do not form a part of this specification document.
- Electrical specifications and performance data contained in this specification document are based on Mini-Circuit's applicable established test performance criteria and measurement instructions.
- The parts covered by this specification document are subject to Mini-Circuits standard limited warranty and terms and conditions (collectively, "Standard Terms"); Purchasers of this part are entitled to the rights and benefits contained therein. For a full statement of the Standard Terms and the exclusive rights and remedies thereunder, please visit Mini-Circuits' website at www.minicircuits.com/MCLStore/terms.jsp