

Low Noise Amplifier

TAMP-72LN+

50Ω 400 to 700 MHz

The Big Deal:

- High IP3, 36 dBm typ.
- Low Noise Figure, 1.0 dB typ.
- Integrated Bias Matching and Stability Circuits

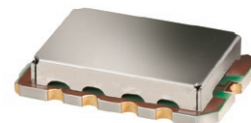

Pricing: \$11.95 (QTY 5-49)

Product Overview:

The TAMP-72LN+ (RoHS compliant) utilizes advanced E-PHEMT technology in a single stage low noise amplifier design built into a shielded case (size: .591"x.394"x.118"). The drop-in module offers low noise figure and moderate gain with good input and output return loss over the entire frequency range and without the need of external matching components.

Key Features

Feature	Advantages
High IP3	At +36 dBm IP3, in combination with its low noise performance, the TAMP-72LN+ can improve a systems' spur-free dynamic range which is often the critical driver in many receiver applications.
Low NF	With only 1.0 dB NF, the TAMP-72LN+ enables greater sensitivity for receiver applications. It includes all matching and stability circuits making this Drop-in LNA module a turn-key solution for ensuring system sensitivity in demanding applications.
Output Power, +21.5 dBm	Provides a good safety margin against damage or saturation from unwanted high power RF signals present at the input to a receiver.
Well Matched input/ output ports	With typical input VSWR of 1.35:1 and output VSWR of 1.15:1, the TAMP-72LN+ can be used in cascade with many 50 Ohm components and maintain minimal interaction or reflections.
Drop-in Module	Eliminates the need for designers to optimize low noise transistor bias and matching circuitry. The TAMP-72LN+ provides the outstanding combined performance and does not require any external elements. The case PCB area is smaller than most LNA transistor designs with external circuitry
Metal Case	Provides a protective enclosure improving handling robustness in addition to shielding the sensitive high gain devices from close by circuitry.
Unconditionally stable	No adverse effects due to loading of the input and output ports avoiding potential instability which can be a critical requirement when integrating high gain, high frequency devices on an open PCB assembly.



For detailed performance specs & shopping online see web site

P.O. Box 350166, Brooklyn, New York 11235-0003 (718) 934-4500 Fax (718) 332-4661 *The Design Engineers Search Engine* Provides ACTUAL Data Instantly at minicircuits.com

Notes: 1. Performance and quality attributes and conditions not expressly stated in this specification sheet are intended to be excluded and do not form a part of this specification sheet. 2. Electrical specifications and performance data contained herein are based on Mini-Circuit's applicable established test performance criteria and measurement instructions. 3. The parts covered by this specification sheet are subject to Mini-Circuits standard limited warranty and terms and conditions (collectively, "Standard Terms"); Purchasers of this part are entitled to the rights and benefits contained therein. For a full statement of the Standard Terms and the exclusive rights and remedies thereunder, please visit Mini-Circuits' website at www.minicircuits.com/MCLStore/terms.jsp.

Low Noise Amplifier

TAMP-72LN+

50Ω

400 to 700 MHz

Features

- Ultra low noise figure, 1 dB typ.
- Output power, up to +21.5 dBm typ.
- Good output IP3, 36 dBm typ.
- Good return loss
- Unconditionally stable

Applications

- PSR (Public Safety Radio)
- Front-end amplifier
- Cellular
- Base transceiver station, tower mounted amplifier, repeater
- General purpose low noise amplifier

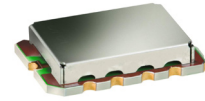

CASE STYLE: JQ1382
PRICE: \$11.95 ea. QTY (5-49)

+ RoHS compliant in accordance with EU Directive (2002/95/EC)

The +Suffix has been added in order to identify RoHS Compliance. See our web site for RoHS Compliance methodologies and qualifications.

Electrical Specifications at 25°C

Parameter	Condition (MHz)	Min.	Typ.	Max.	Units
Frequency Range		400		700	MHz
Noise Figure	400 - 700		1.0	1.2	dB
Gain	400 - 700	16.5	20.0		dB
Gain Flatness	400 - 700		± 1.3	± 2.0	dB
Output Power at 1dB compression	400 - 700	18.5	21.5		dBm
Output third order intercept point (OIP3)	400 - 700		36		dBm
Input VSWR	400 - 700		1.35		:1
Output VSWR	400 - 700		1.15		:1
DC Supply Voltage			5.0		V
Supply Current			90	120	mA

Pin Connections

RF IN	10
RF OUT	5
V+	7
GROUND	1,2,3,4,6,8,9,11

Maximum Ratings

Parameter	Ratings
Operating Temperature	-40°C to 85°C
Storage Temperature	-55°C to 100°C
Operating Voltage	5.5 V
Input Power (no damage)	+27 dBm
Power Consumption	660 mW

Permanent damage may occur if any of these limits are exceeded.

Outline Drawing

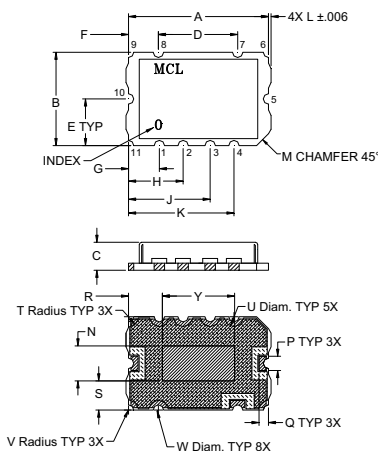

PCB Land Pattern

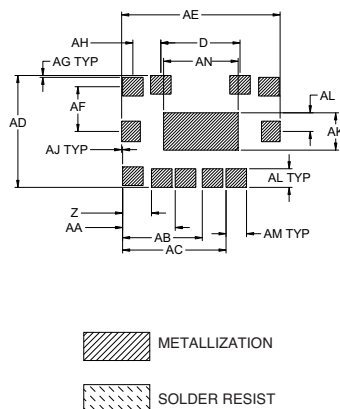

Demo Board MCL P/N: TB-468+ Suggested PCB Layout (PL-293)

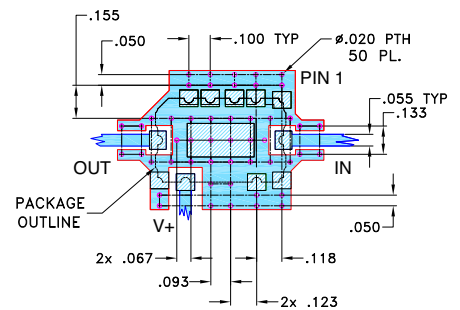

NOTES:

1. TRACE WIDTH IS SHOWN FOR ROGERS RO4350B WITH DIELECTRIC THICKNESS .030" ± .002; COPPER 1/2 OZ. EACH SIDE. FOR OTHER MATERIALS TRACE WIDTH MAY NEED TO BE MODIFIED.
2. BOTTOM SIDE OF THE PCB IS CONTINUOUS GROUND PLANE.
 - DENOTES PCB COPPER LAYOUT WITH SMOBC (SOLDER MASK OVER BARE COPPER)
 - DENOTES COPPER LAND PATTERN FREE OF SOLDER MASK

Outline Dimensions (inch/mm)

A	B	C	D	E	F	G	H	J	K	L	M	N	P	Q	R	S	T	U
.591	.394	.118	.335	.197	.126	.130	.230	.344	.445	.011	.050	.148	.060	.040	.143	.123	.042	.084
15.0	10.0	3.0	8.5	5.0	3.2	3.3	5.85	8.75	11.3	.28	1.27	3.75	1.52	1.02	3.63	3.13	1.07	2.13
V	W	Y	Z	AA	AB	AC	AD	AE	AF	AG	AH	AJ	AK	AL	AM	AN	wt.	
.022	.044	.305	.122	.222	.337	.437	.472	.669	.189	.008	.118	.004	.158	.079	.087	.315	grams	
.56	1.12	7.75	3.1	5.65	8.55	11.1	12.0	17.0	4.8	.20	3.0	.10	4.0	2.0	2.2	8.0		0.8



For detailed performance specs & shopping online see web site

P.O. Box 350166, Brooklyn, New York 11235-0003 (718) 934-4500 Fax (718) 332-4661 The Design Engineers Search Engine

Provides ACTUAL Data Instantly at minicircuits.com

IF/RF MICROWAVE COMPONENTS

Notes: 1. Performance and quality attributes and conditions not expressly stated in this specification sheet are intended to be excluded and do not form a part of this specification sheet. 2. Electrical specifications and performance data contained herein are based on Mini-Circuit's applicable established test performance criteria and measurement instructions. 3. The parts covered by this specification sheet are subject to Mini-Circuits standard limited warranty and terms and conditions (collectively, "Standard Terms"); Purchasers of this part are entitled to the rights and benefits contained therein. For a full statement of the Standard Terms and the exclusive rights and remedies thereunder, please visit Mini-Circuits' website at www.minicircuits.com/MCLStore/terms.jsp.

REV. OR
M124620
TAMP-72LN+
EDR-9732/2
RAV
090924
Page 2 of 3

FREQUENCY (MHz)	GAIN (dB)	DIRECTIVITY (dB)	VSWR IN (:1)	VSWR OUT (:1)	NOISE FIGURE (dB)	P. OUT @ 1dB COMPR. (dBm)	OUTPUT IP3 (dBm)
400.00	21.30	4.75	1.29	1.32	0.94	20.90	35.56
420.00	21.12	4.82	1.30	1.30	0.97	20.88	35.59
440.00	20.93	4.74	1.30	1.27	0.97	20.92	35.92
460.00	20.75	4.79	1.30	1.25	0.97	21.12	35.71
480.00	20.57	4.62	1.32	1.22	0.98	21.18	35.65
500.00	20.39	4.90	1.33	1.21	0.96	20.99	36.00
520.00	20.22	4.73	1.34	1.19	0.97	21.12	35.71
540.00	20.05	4.75	1.35	1.18	0.97	21.33	35.87
560.00	19.86	4.88	1.36	1.16	0.97	21.27	36.13
570.00	19.78	4.60	1.36	1.16	0.96	21.21	35.86
580.00	19.70	4.82	1.37	1.14	0.96	21.29	35.64
590.00	19.62	4.68	1.37	1.14	0.95	21.29	35.82
600.00	19.54	4.79	1.37	1.14	0.96	21.24	35.67
610.00	19.46	4.70	1.38	1.13	0.97	21.37	36.22
620.00	19.37	4.73	1.39	1.12	0.96	21.31	36.73
630.00	19.29	4.80	1.39	1.12	0.96	21.43	36.53
640.00	19.21	4.72	1.39	1.11	0.96	21.41	36.48
660.00	19.06	4.79	1.40	1.10	0.95	21.21	36.43
680.00	18.89	4.80	1.41	1.10	0.97	21.40	36.71
700.00	18.72	4.81	1.41	1.09	0.95	21.43	36.20

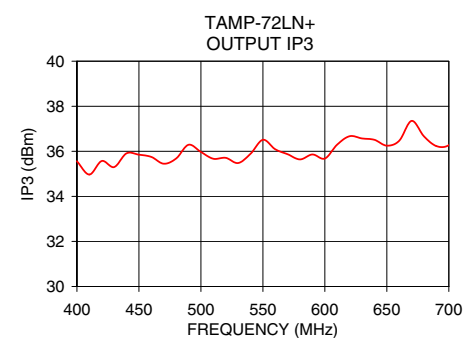
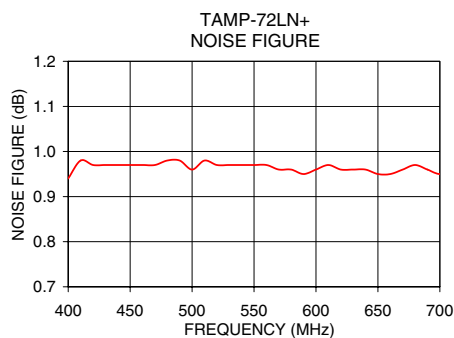
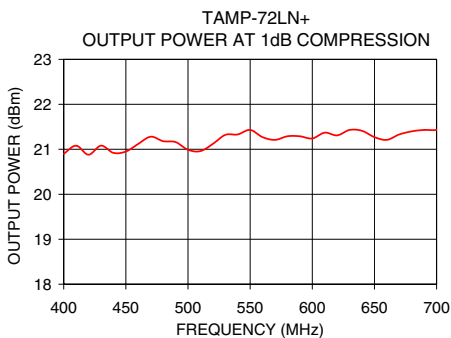
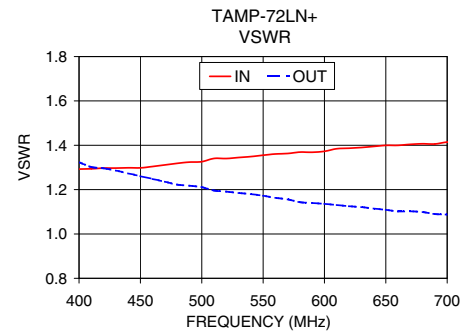
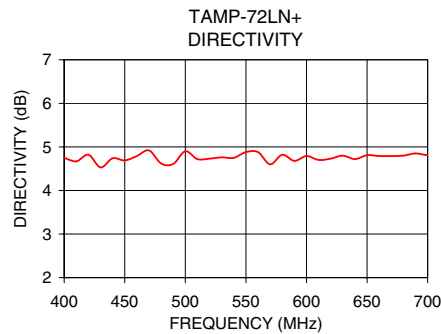
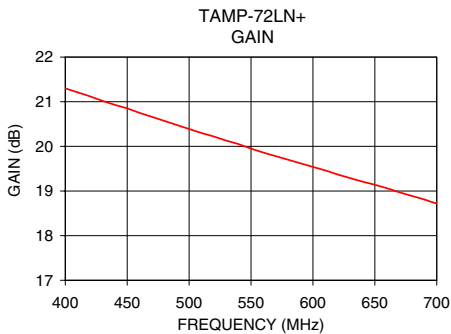

For detailed performance specs & shopping online see web site

P.O. Box 350166, Brooklyn, New York 11235-0003 (718) 934-4500 Fax (718) 332-4661 The Design Engineers Search Engine Provides ACTUAL Data Instantly at minicircuits.com

Notes: 1. Performance and quality attributes and conditions not expressly stated in this specification sheet are intended to be excluded and do not form a part of this specification sheet. 2. Electrical specifications and performance data contained herein are based on Mini-Circuit's applicable established test performance criteria and measurement instructions. 3. The parts covered by this specification sheet are subject to Mini-Circuits standard limited warranty and terms and conditions (collectively, "Standard Terms"); Purchasers of this part are entitled to the rights and benefits contained therein. For a full statement of the Standard Terms and the exclusive rights and remedies thereunder, please visit Mini-Circuits' website at www.minicircuits.com/MCLStore/terms.jsp.