

# High Power Bi-Directional Coupler

## SYBD-23-13HP+

50Ω 23dB Coupling DC Pass 800 to 1000 MHz



CASE STYLE: JB1233  
PRICE: \$29.95 ea. QTY (1-9)

+ RoHS compliant in accordance with EU Directive (2002/95/EC)

The + suffix has been added in order to identify RoHS Compliance. See our web site for RoHS Compliance methodologies and qualifications.

### Maximum Ratings

Operating Temperature	-55°C to 100°C
Storage Temperature	-55°C to 100°C
DC Current	2A

Permanent damage may occur if any of these limits are exceeded.

### Pin Connections

INPUT	1
OUTPUT	2
COUPLED (forward)	4
COUPLED (reverse)	3
GROUND	5

### Features

- high power handling, 100 watts max.
- low mainline loss, 0.06 dB typ.
- excellent VSWR, 1.15:1 typ.
- excellent directivity, 27 dB typ.

### Applications

- cellular

### Bi-Directional Coupler Electrical Specifications

FREQ. (MHz)	COUPLING (dB)		MAINLINE LOSS <sup>1</sup> (dB)		DIRECTIVITY (dB)		VSWR (:1)	POWER INPUT (W)
	Nom.	Flatness	Typ.	Max.	Typ.	Min.		
$f_L - f_U$								
800-1000	23.5±0.8	±1.3	0.06	0.25	27	19	1.15	100
800-900	24.0±0.8	±0.7	0.06	0.25	27	19	1.15	100
900-1000	23.0±0.8	±0.6	0.06	0.25	27	19	1.15	100

1. Mainline loss includes theoretical power loss at coupled port.

### Typical Performance Data

Frequency (MHz)	Mainline Loss (dB)		Coupling (dB)		Directivity (dB)		Return Loss (dB)		
	In-Out	In-Cpl Fwd	Out-Cpl Rev	Out-Cpl Fwd	In-Cpl Rev	In	Out	Cpl Fwd	Cpl Rev
800.00	0.03	24.74	24.77	28.05	28.39	33.01	32.49	35.43	35.09
820.00	0.03	24.54	24.57	28.00	28.28	32.55	31.97	34.93	34.57
860.00	0.04	24.14	24.17	27.84	27.98	31.49	31.01	33.95	33.79
880.00	0.03	23.95	23.98	27.64	28.10	30.94	30.49	33.59	33.56
900.00	0.04	23.76	23.79	27.62	28.12	30.55	30.08	33.34	33.16
920.00	0.04	23.58	23.61	27.50	27.94	30.23	29.78	33.09	32.81
940.00	0.04	23.41	23.44	27.32	27.80	29.89	29.42	32.77	32.49
960.00	0.05	23.23	23.27	27.25	27.84	29.59	29.11	32.48	32.30
980.00	0.04	23.06	23.09	27.25	27.95	29.36	28.87	32.28	32.27
1000.00	0.04	22.89	22.93	27.22	27.98	29.09	28.66	32.18	32.23

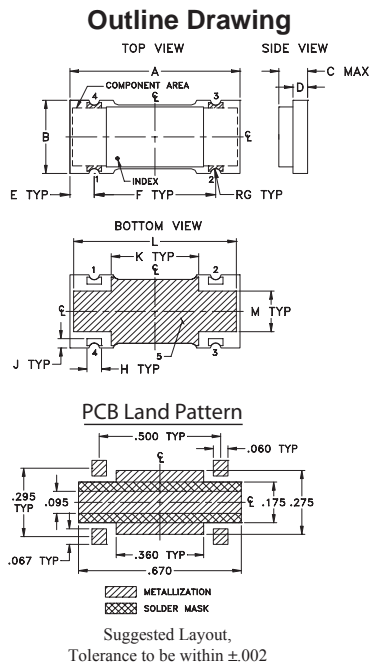

### Outline Dimensions (inch/mm)

A	B	C	D	E	F	G
.70	.32	.13	.060	.100	.500	.022
17.78	8.13	3.30	1.52	2.54	12.70	0.56

H	J	K	L	M	wt
.060	.040	.360	.670	.175	grams
1.52	1.02	9.14	17.02	4.45	0.68

### Demo Board MCL P/N: TB-398 Suggested PCB Layout (PL-260)

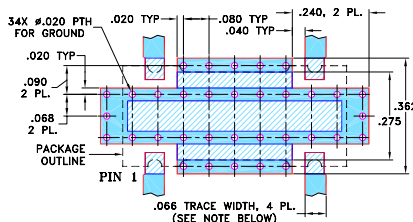

- NOTES: 1. TRACE WIDTH IS SHOWN FOR ROGERS RO4350B WITH DIELECTRIC THICKNESS .030" ± .002"; COPPER: 1/2 OZ. EACH SIDE. FOR OTHER MATERIALS TRACE WIDTH MAY NEED TO BE MODIFIED. 2. BOTTOM SIDE OF THE PCB IS CONTINUOUS GROUND PLANE.

- DENOTES PCB COPPER LAYOUT WITH SMOBC (SOLDER MASK OVER BARE COPPER)
- DENOTES COPPER LAND PATTERN FREE OF SOLDER MASK

P.O. Box 350166, Brooklyn, New York 11235-0003 (718) 934-4500 Fax (718) 332-4661 The Design Engineers Search Engine Provides ACTUAL Data Instantly at [minicircuits.com](http://minicircuits.com)

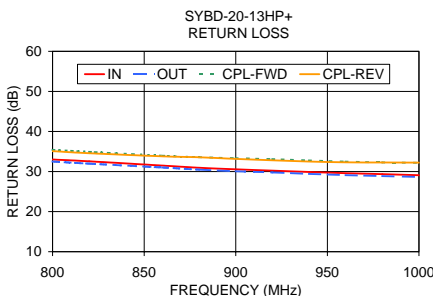
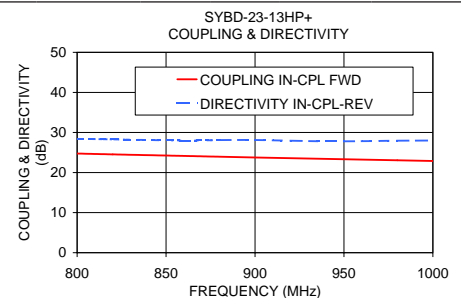
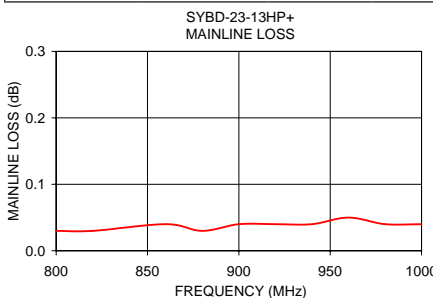

### Electrical Schematic

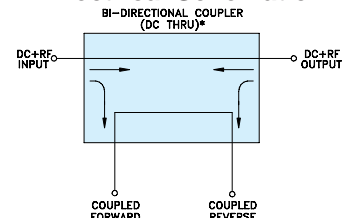

\* ELECTRICAL SCHEMATIC IS FOR BI-DIRECTIONAL COUPLER WITHOUT INTERNAL TRANSFORMERS AND RESISTORS.

For detailed performance specs & shipping online see web site

REV. A  
M119986  
ED-12713/5  
SYBD-20-13HP+  
WZ/CP/AM  
090911

Notes: 1. Performance and quality attributes and conditions not expressly stated in this specification sheet are intended to be excluded and do not form a part of this specification sheet. 2. Electrical specifications and performance data contained herein are based on Mini-Circuit's applicable established test performance criteria and measurement instructions. 3. The parts covered by this specification sheet are subject to Mini-Circuit's standard limited warranty and terms and conditions (collectively, "Standard Terms"); Purchasers of this part are entitled to the rights and benefits contained therein. For a full statement of the Standard Terms and the exclusive rights and remedies thereunder, please visit Mini-Circuit's website at [www.minicircuits.com/MCLStore/terms.jsp](http://www.minicircuits.com/MCLStore/terms.jsp).