

High Power Bi-Directional Coupler

SYBD-16-172HP+

50Ω 16dB Coupling DC Pass 1400 to 1750 MHz



CASE STYLE: JB1233
PRICE: \$29.95 ea. QTY (1-9)

+ RoHS compliant in accordance with EU Directive (2002/95/EC)

The + suffix has been added in order to identify RoHS Compliance. See our web site for RoHS Compliance methodologies and qualifications.

Maximum Ratings

Operating Temperature	-55°C to 100°C
Storage Temperature	-55°C to 100°C
DC Current	2A
Permanent damage may occur if any of these limits are exceeded.	

Pin Connections

INPUT	1
OUTPUT	2
COUPLED (forward)	4
COUPLED (reverse)	3
GROUND	5

Features

- high power handling, 50 watts max.
- low mainline loss, 0.22 dB typ.
- excellent VSWR, 1.10:1 typ.
- excellent directivity, 23 dB typ.
- wideband frequency, 1400 to 1750 MHz

Applications

- GPS
- instrumentation
- defense communications

Bi-Directional Coupler Electrical Specifications

FREQ. (MHz)	COUPLING (dB)		MAINLINE LOSS ¹ (dB)		DIRECTIVITY (dB)		VSWR (:1)	POWER INPUT (W)
	Nom.	Flatness	Typ.	Max.	Typ.	Min.		
$f_c - f_u$								
1400-1750			0.22	0.5	23	18	1.10	
1400-1580	17.0±0.7	±0.7	0.20	0.45	23	18	1.10	50
1580-1750	16.0±0.7	±0.6	0.22	0.50	23	17	1.10	25

1. Mainline loss includes theoretical power loss at coupled port.

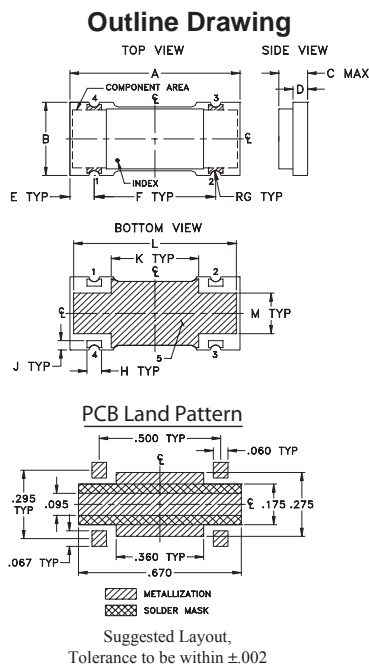

Outline Dimensions (inch/mm)

A	B	C	D	E	F	G
.70	.32	.13	.060	.100	.500	.022
17.78	8.13	3.30	1.52	2.54	12.70	0.56
H	J	K	L	M	wt	
.060	.040	.360	.670	.175	grams	
1.52	1.02	9.14	17.02	4.45	0.68	

Demo Board MCL P/N: TB-398
Suggested PCB Layout (PL-260)

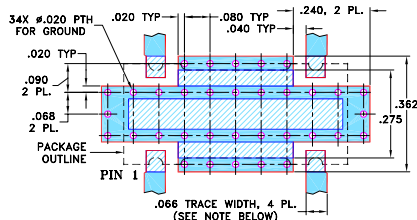

- NOTES: 1. TRACE WIDTH IS SHOWN FOR ROGERS RO4350B WITH DIELECTRIC THICKNESS .030" ± .002"; COPPER: 1/2 OZ. EACH SIDE. FOR OTHER MATERIALS TRACE WIDTH MAY NEED TO BE MODIFIED.
2. BOTTOM SIDE OF THE PCB IS CONTINUOUS GROUND PLANE.

- DENOTES PCB COPPER LAYOUT WITH SMOBC (SOLDER MASK OVER BARE COPPER)
- DENOTES COPPER LAND PATTERN FREE OF SOLDER MASK

P.O. Box 350166, Brooklyn, New York 11235-0003 (718) 934-4500 Fax (718) 332-4661 The Design Engineers Search Engine Provides ACTUAL Data Instantly at minicircuits.com

IR/RF MICROWAVE COMPONENTS

Notes: 1. Performance and quality attributes and conditions not expressly stated in this specification sheet are intended to be excluded and do not form a part of this specification sheet. 2. Electrical specifications and performance data contained herein are based on Mini-Circuit's applicable established test performance criteria and measurement instructions. 3. The parts covered by this specification sheet are subject to Mini-Circuits standard limited warranty and terms and conditions (collectively, "Standard Terms"); Purchasers of this part are entitled to the rights and benefits contained therein. For a full statement of the Standard Terms and the exclusive rights and remedies thereunder, please visit Mini-Circuits' website at www.minicircuits.com/MCLStore/terms.jsp.

Typical Performance Data

Frequency (MHz)	Mainline Loss (dB)		Coupling (dB)		Directivity (dB)		Return Loss (dB)		
	In-Out	In-Cpl Fwd	Out-Cpl Rev	Out-Cpl Fwd	In-Cpl Rev	In	Out	Cpl Fwd	Cpl Rev
1400.00	0.19	17.18	17.13	24.96	26.06	29.33	26.82	32.71	33.70
1440.00	0.19	16.96	16.90	24.98	26.04	30.09	27.42	33.65	34.76
1480.00	0.20	16.74	16.69	25.00	25.82	31.14	28.29	35.49	37.02
1520.00	0.20	16.54	16.49	25.14	25.87	32.58	29.43	37.65	40.00
1580.00	0.21	16.24	16.19	25.05	25.94	34.80	31.26	42.49	45.85
1620.00	0.21	16.04	15.99	25.20	25.85	36.75	33.41	44.47	44.86
1660.00	0.22	15.86	15.81	25.10	25.75	37.67	35.64	43.01	42.20
1700.00	0.23	15.69	15.64	24.79	25.51	37.14	38.63	40.47	39.42
1740.00	0.23	15.52	15.47	24.88	25.47	34.91	42.40	36.76	35.45
1750.00	0.24	15.48	15.44	24.90	25.49	34.46	42.66	36.15	34.86

SYBD-16-172HP+
MAINLINE LOSS

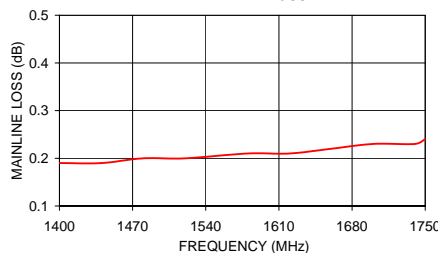

SYBD-16-172HP+
COUPLING & DIRECTIVITY

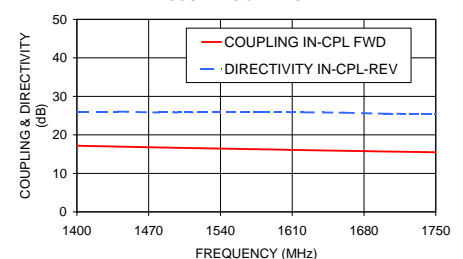

SYBD-16-172HP+
RETURN LOSS

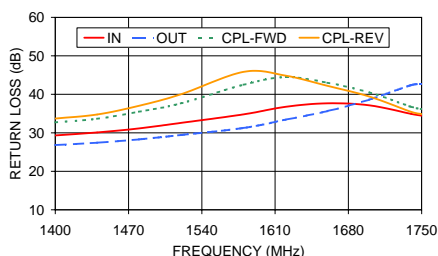

Electrical Schematic

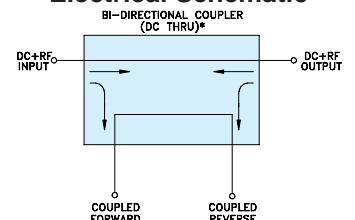

* ELECTRICAL SCHEMATIC IS FOR BI-DIRECTIONAL COUPLER WITHOUT INTERNAL TRANSFORMERS AND RESISTORS.

For detailed performance specs & shopping online see web site

REV. A
M119986
ED-12762/3
SYBD-16-172HP+
WZ/CP/AM
090911