

# Programmable Attenuator

RCDAT-3000-63W2

50Ω 0 – 63 dB, 2 Watt, 1 dB step 50 to 3000 MHz

## The Big Deal

- High power handling (Up to 2W)
- Wide attenuation range, 63 dB
- Short attenuation transition time (800 nsec)
- Compact size, 2.5 x 3.0 x 0.85"
- **USB and Ethernet control**



Software Package

Case Style: MS2065

## Product Overview

Mini-Circuits' RCDAT-3000-63W2 is a general purpose, single channel programmable attenuator suitable for a wide range of signal level control applications from 50 MHz to 3 GHz. The Attenuator provides 0 to 63 dB attenuation in 1 dB steps. Its unique design maintains linear attenuation change per dB, even at the highest attenuation settings.

The attenuator is housed in a compact and rugged package with SMA female connectors on the bi-directional input and output RF ports, a standard Ethernet port (RJ45) and a USB type Mini-B power and control port.

The attenuator can be controlled via USB or Ethernet (supporting both HTTP and Telnet network protocols). Full software support is provided and can be downloaded from our website any time at <http://www.minicircuits.com/softwaredownload/patt.html>. The package includes our user-friendly GUI application for Windows® and a full API with programming instructions for Windows® and Linux® environments (both 32-bit and 64-bit systems).

## Key Features

Feature	Advantages
Ethernet control	The RCDAT-3000-63W2 can be controlled from any Windows® or Linux® computer with a network connection using either HTTP or Telnet protocols, giving the user layout flexibility and freedom to operate a test setup remotely from almost anywhere.
USB control	The user may also control the RCDAT-3000-63W2 via USB connection. The device draws all power requirements through the USB port.
Programmable attenuation sweep and Hop sequences	The RCDAT-3000-63W2 can be programmed with a timed sequence of attenuation settings, to run without any additional external control
Plug-and-Play – no additional device drivers required.	Fast and easy setup and installation. The RCDAT-3000-63W2 interfaces with various third-party software, making it easy to integrate into existing setups.
63 dB attenuation range.	The RCDAT-3000-63W2 provides high-accuracy attenuation up to 63 dB in 1 dB steps, allowing the user precise level control over a broad attenuation and frequency range.
High linearity	Typical input IP3 of +54 dBm up to 3000 MHz

**Trademarks:** Windows is a registered trademark of Microsoft Corporation in the United States and other countries. Linux is a registered trademark of Linus Torvalds. Mac is a registered trademark of Apple Corporation. Pentium is a registered trademark of Intel Corporation. Neither Mini-Circuits nor the Mini-Circuits RCDAT-series attenuators are affiliated with or endorsed by the owners of the above referenced trademarks.

Mini-Circuits and the Mini-Circuits logo are registered trademarks of Scientific Components Corporation.



50Ω 0 – 63 dB, 2 Watt, 1 dB step 50 to 3000 MHz

## Features

- USB and Ethernet control (HTTP and Telnet)
- Very good attenuation accuracy, ±0.4 dB typ.
- Short attenuation transition time (800 nsec)
- Sweep and Hop attenuation sequences
- Extremely low leakage
- Interchangeable Input/Output ports
- Plug & Play device – no drivers required
- User-friendly Windows® Graphical User Interface
- Supports a wide range of programming environments (See application note [AN-49-001](#) for details)
- Optional mounting bracket, see page 5



Software Package

Case Style: MS2065

### Included Accessories

Model No.	Description	Qty.
USB-AC/DC-5	AC/DC 5V adapter	1
MUSB-CBL-3+	2.6 ft. USB cable	1

## Applications

- Automated Test Equipment (ATE)
- WiMAX, 3G, 4G, LTE, DVB Fading Simulators
- Laboratory Instrumentation
- Production Test
- Handover system Evaluation
- Power level cycling

### RoHS Compliant

See our web site for RoHS Compliance methodologies and qualifications

## Mini-Circuits Graphical User Interface for RCDAT-Series Programmable Attenuator

RCDAT GUI screen (USB control)

RCDAT GUI screen (Ethernet control)

For programming instructions, see [programming guide](#) on Mini-Circuits' website.



## Electrical Specifications <sup>1</sup> at 0°C to 50°C

Parameter	Frequency range	Conditions	Min.	Typ.	Max.	Units
Attenuation range	50 - 3000 MHz	1 dB step	0	-	63	dB
Attenuation accuracy	50 - 1000 MHz	@ 1 - 15 dB @ 16 - 63 dB	-	±0.05 ±0.20	±0.35 ±0.8	dB
	1000 - 2000 MHz	@ 1 - 15 dB @ 16 - 48 dB @ 49 - 63 dB	-	±0.30 ±0.30 ±0.65	±1.0 ±1.1 ±1.8	
	2000 - 3000 MHz	@ 1 - 15 dB @ 16 - 48 dB @ 49 - 63 dB	-	±0.45 ±0.55 ±1.05	±1.4 ±1.5 ±2.0	
Insertion Loss	50 - 1000 MHz	@ 0 dB	-	3.3	4.5	dB
	1000 - 2000 MHz		-	4.4	5.5	
	2000 - 3000 MHz		-	5.8	7.5	
Isolation In-Out	50 - 3000 MHz	Note 2	64	-	72	dB
Input operating power <sup>3</sup> (RF In and RF Out out ports)	50 - 3000 MHz	@ 0 - 63 dB	-	-	+33	dBm
IP3 Input <sup>4</sup>	50 - 3000 MHz	@ 0 dB setting (P <sub>IN</sub> =+5 dBm)	-	+54	-	dBm
VSWR	50 - 500 MHz	@ 0 - 63 dB	-	1.15	1.65	:1
	500 - 1500 MHz		-	1.20	1.45	
	1500 - 3000 MHz		-	1.40	2.00	
Min Dwell Time <sup>5</sup>	50 - 3000 MHz	High speed mode	-	400	-	µsec
Attenuation Transition Time <sup>6</sup>	50 - 3000 MHz	-	-	800	-	nSec
Supply Voltage	-	via USB port	4.75	5	5.25	V
USB current draw	-	-	-	190	250	mA
Ethernet communication	Supports both Telnet and HTTP protocols over TCP/IP with dynamic(DHCP) or static IP					

<sup>1</sup> Attenuator RF ports are interchangeable, and support simultaneous, bidirectional signal transmission, however the specifications are guaranteed for the RF in and RF out as noted on the label. There may be minor changes in performance when injecting signals to the RF Out port.

<sup>2</sup> Isolation is defined as max attenuation plus insertion loss; this is the path loss through the attenuator when initially powered up. After a brief delay (~0.5 sec typically) the attenuator will revert to a user defined "power-up" state (either max attenuation or a pre-set value).

<sup>3</sup> Total operating input power from both RF In and RF Out out ports. Compression level not noted as it exceeds max safe operating power level.

<sup>4</sup> Tested with 1 MHz span between signals.

<sup>5</sup> Minimum Dwell Time is the time the RCDAT will take to respond to a command to change attenuation states without communication delays. In PC control add communication delays (on the order of msec for USB) to get actual response time.

<sup>6</sup> Attenuation Transition Time is specified as the time between starting to change the attenuation state and settling on the requested attenuation state.

## Absolute Maximum Ratings

Operating Temperature	0°C to 50°C
Case Temperature over ambient	15°C
Storage Temperature	-20°C to 85°C
V <sub>USB</sub> Max.	6V
Total RF power for RF In & RF Out	+35 dBm

Permanent damage may occur if any of these limits are exceeded. Operating in the range between operating power limits and absolute maximum ratings for extended periods of time may result in reduced life and reliability.

## Minimum System Requirements

Interface	USB HID or HTTP Get/Post or Telnet protocols
Host operating system - USB Control	<b>Windows 32/64 Bit operating system:</b> Windows 98®, Windows XP®, Windows Vista®, Windows 7®, Windows 8®, Windows 10® <b>Linux® support:</b> 32/64 Bit operating system
Host operating system - Ethernet Control	Any Windows®, Mac®, or Linux® computer with a network port and Ethernet-TCP/IP (HTTP or Telnet protocols) support
Hardware	Pentium® II or better

## RCDAT response to communication interrupt

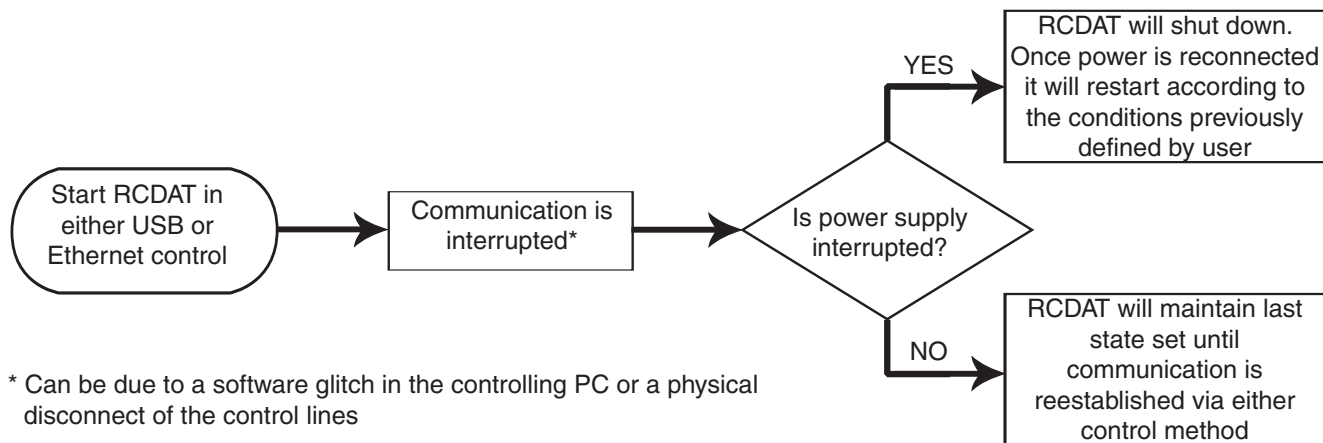

## Block Diagram

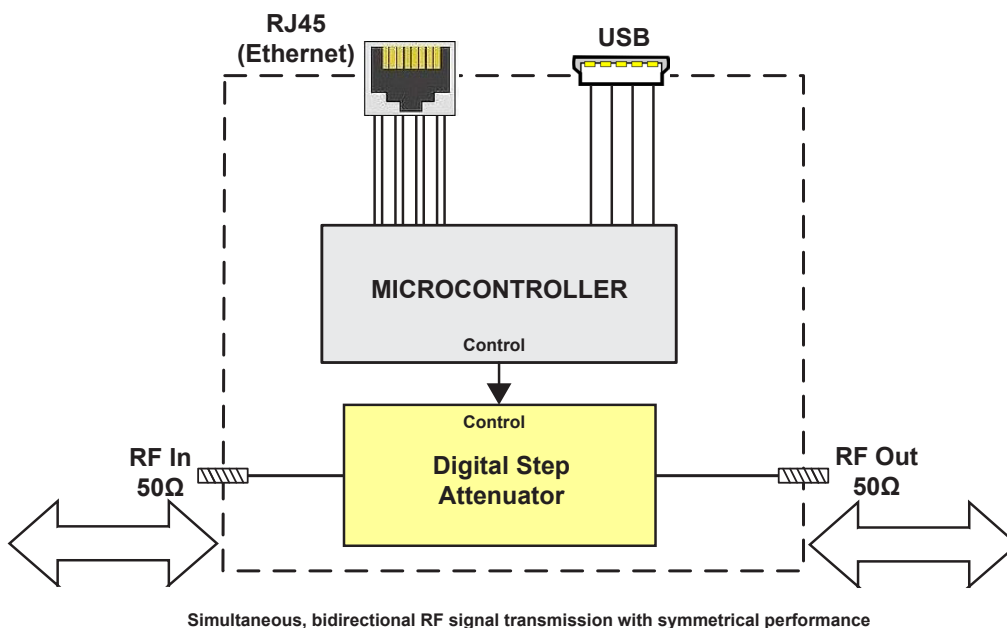

## Connections

RF In	(SMA female)
RF Out	(SMA female)
USB	(USB type Mini-B female)
Network (Ethernet/LAN)	(RJ45 socket)

## Outline Drawing (MS2065)

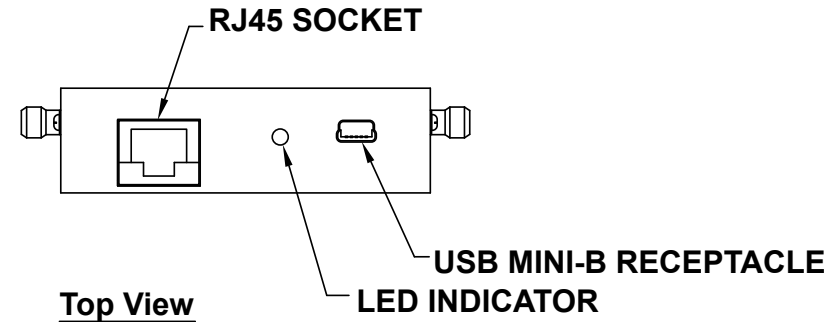

## Connections

RF IN	(SMA female)
RF OUT	(SMA female)
USB	(USB type Mini-B female)
Network (Ethernet/LAN)	(RJ45 socket)

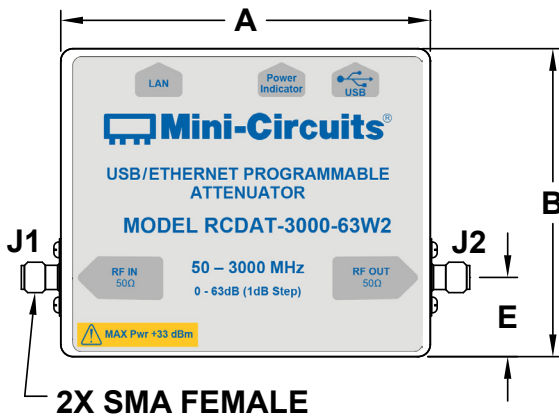

## Bracket Option

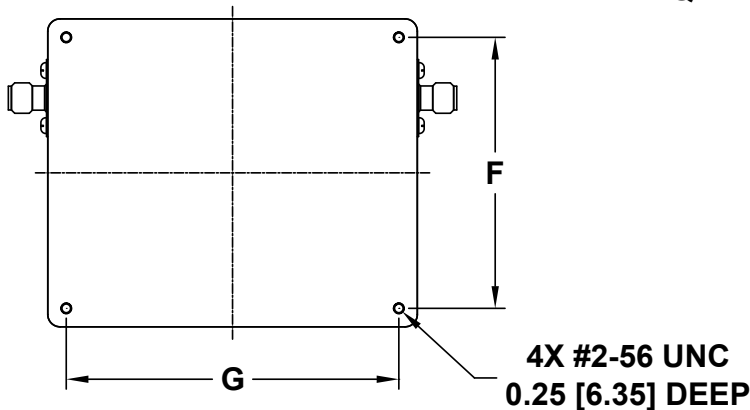
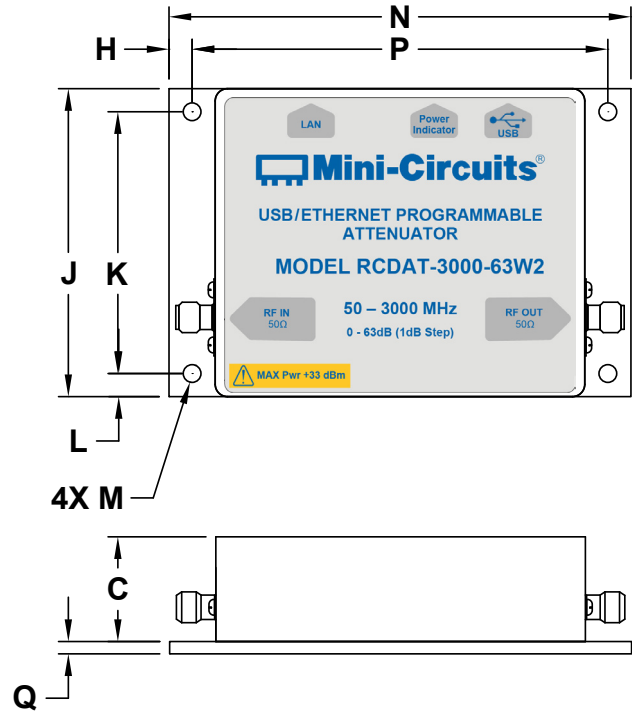

## Instruction for mounting bracket:

1. Tool required: Phillips head screwdriver
2. Mount the bracket over threaded holes on the bottom side with the fasteners provided with the bracket.

## Outline Dimensions (inch/mm)

A	B	C	D	E	F	G	H	J	K	L	M	N	P	Q	WT. GRAMS
3.00	2.50	0.85	0.28	0.64	2.200	2.700	0.188	2.50	2.125	0.188	0.144	3.75	3.375	0.100	200
76.2	63.5	21.6	7.1	16.3	55.88	68.58	4.76	63.5	53.98	4.76	3.66	95.3	85.72	2.54	

## Typical Performance Curves

**Attenuation Accuracy @ +25°C vs. Frequency over Attenuation settings**

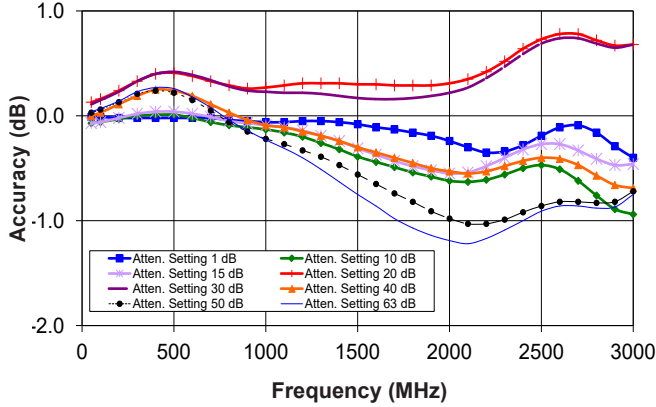

**Attenuation relative to Insertion Loss @ +25°C vs. Frequency over Attenuation settings**

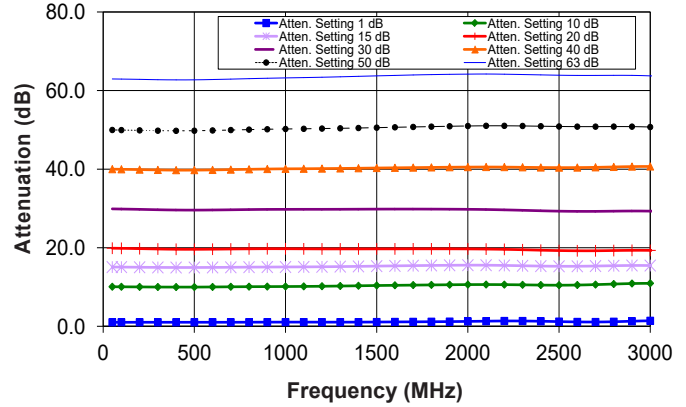

**Attenuation Accuracy @ 0°C vs. Frequency over Attenuation settings**

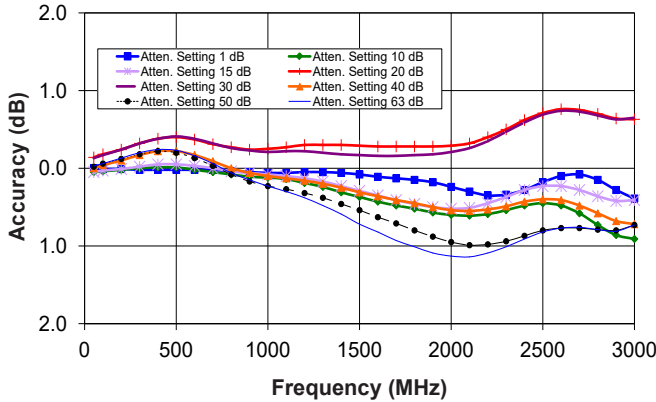

**Attenuation relative to Insertion Loss @ 0°C vs. Frequency over Attenuation settings**

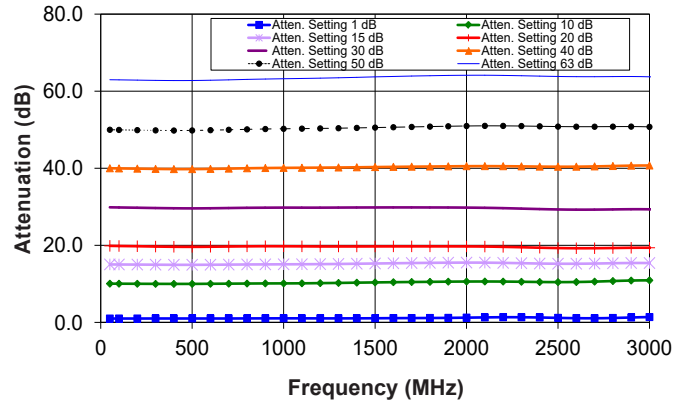

**Attenuation Accuracy @ +50°C vs. Frequency over Attenuation settings**

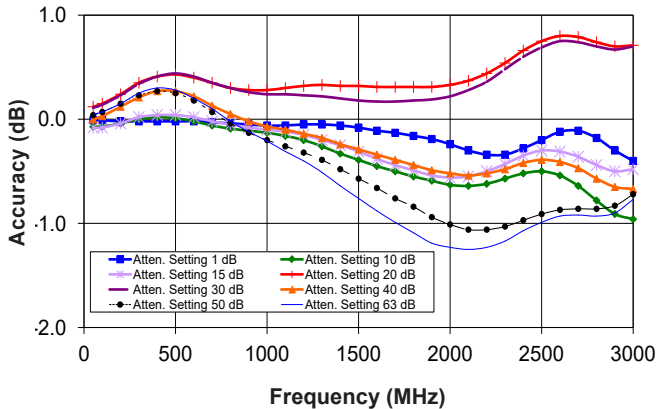

**Attenuation relative to Insertion Loss @ +50°C vs. Frequency over Attenuation settings**

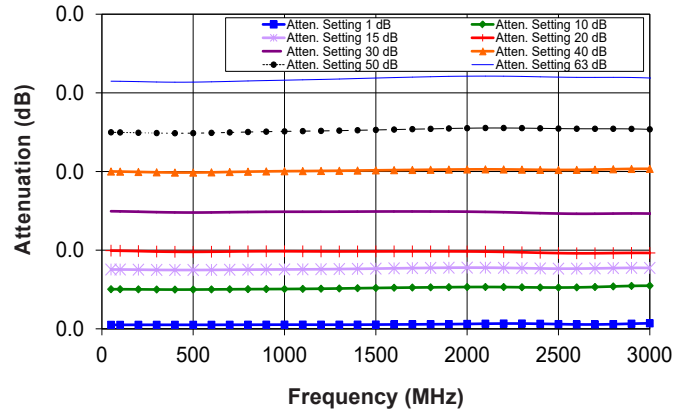

## Typical Performance Curves (Continued)

**Insertion Loss @ Input Power 0dBm vs. Frequency over Temperatures**

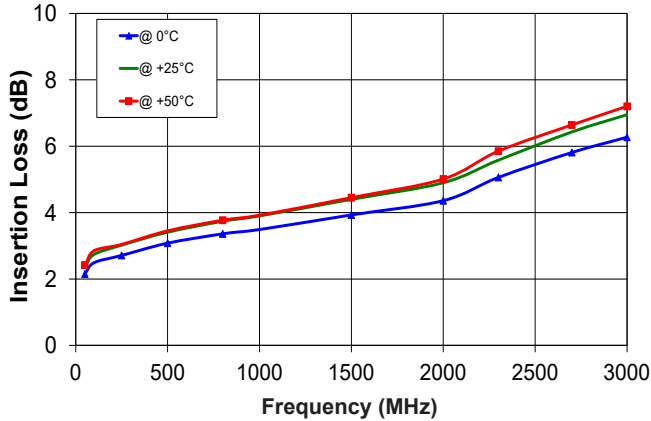

**Insertion Loss @ Input Power +33 dBm vs. Frequency over Temperatures**

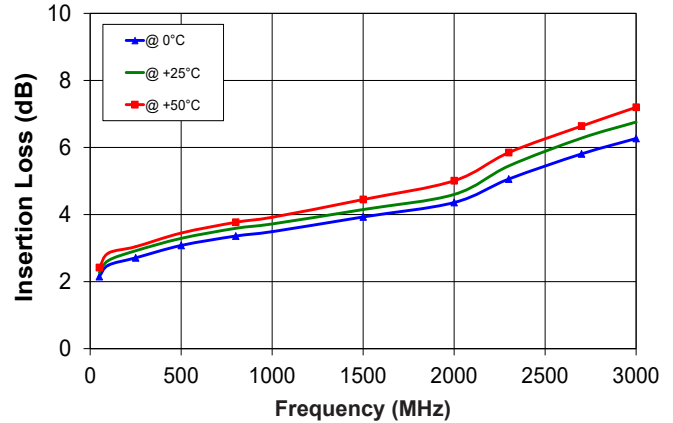

**Output VSWR @ +25°C vs. Frequency over Attenuation settings**

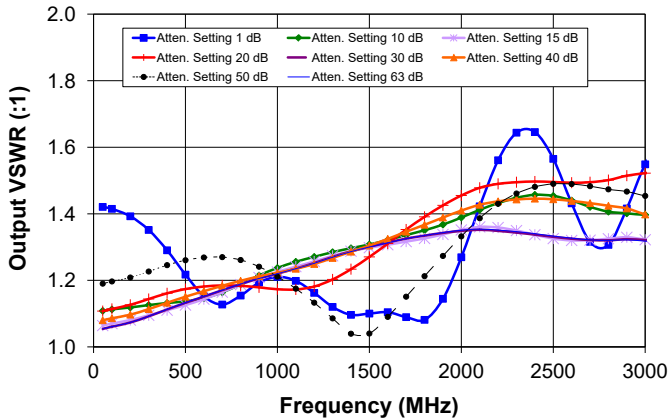

**Input VSWR @ +25°C vs. Frequency over Attenuation settings**

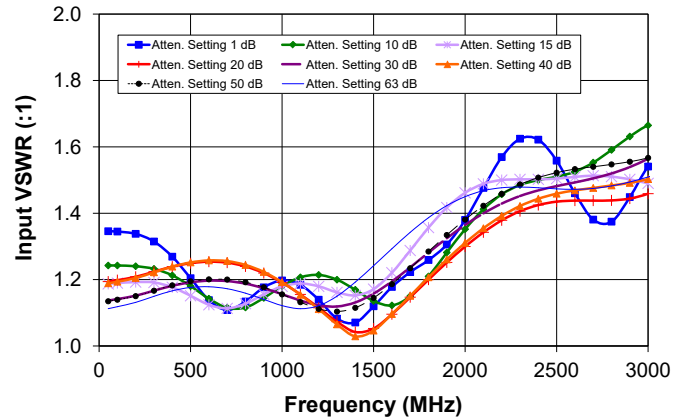

**Input IP3 @ 0dB Attenuation vs. Frequency over Temperatures**

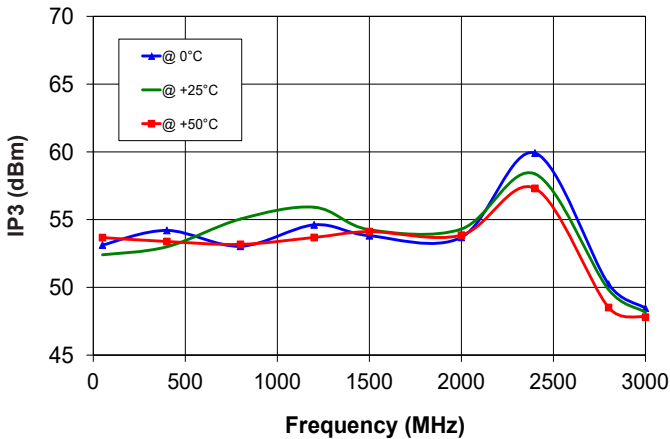

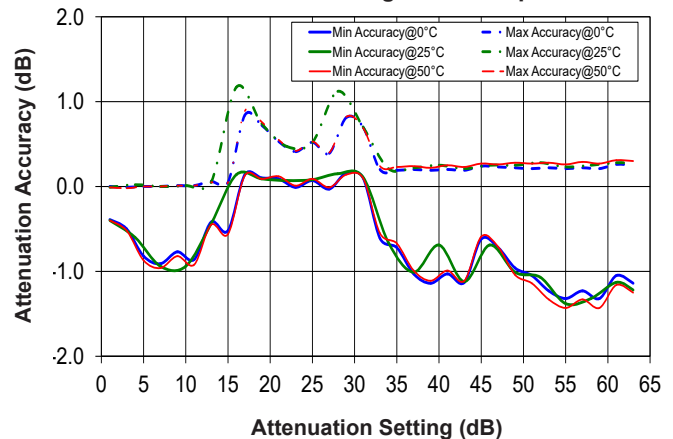

**Typical Attenuation Accuracy vs. Attenuation settings over Temperature**



## Ordering Information

Model	Description
RCDAT-3000-63W2	USB / Ethernet Programmable Attenuator

Included Accessories	Part No.	Description
	USB-AC/DC-5+	AC/DC Power Adapter with US, EU, IL, UK, AUS, and China two pin power plugs <sup>7,8</sup> . Operating temperature: 0°C to +45°C, AC Input: 100-240V, 47-63 Hz, DC Output 5±0.25 V , I <sub>Max</sub> =1A
	MUSB-CBL-3+	2.6 ft (0.8 m) USB Cable: USB type A(Male) to USB type Mini-B(Male)

<sup>7</sup> The USB-AC/DC-5 may be used to provide the 5V<sub>DC</sub> power input via USB port if operating the RCDAT with Ethernet control. Not required if using USB control.

<sup>8</sup> Power plugs for other countries are also available, Plugs for other countries are also available, if you need a power plug for a country not listed please contact [testsolutions@minicircuits.com](mailto:testsolutions@minicircuits.com)

Optional Accessories	Description
USB-AC/DC-5 (spare)	AC/DC 5V <sub>DC</sub> Power Adapter with US, EU, IL, UK, AUS, and China power plugs
MUSB-CBL-3+ (spare)	2.6 ft (0.8 m) USB Cable: USB type A(Male) to USB type Mini-B(Male)
MUSB-CBL-7+	6.6 ft (2.0 m) USB Cable: USB type A(Male) to USB type Mini-B(Male)
PC-DAT-CD	Software CD <sup>9</sup>
BKT-66-02+	Bracket Kit

<sup>9</sup> To receive the CD at no extra cost, request when placing order. CD contents can be downloaded from Mini-Circuits website at <http://www.minicircuits.com/softwaredownload/patt.html>

## Additional Notes

- A. Performance and quality attributes and conditions not expressly stated in this specification document are intended to be excluded and do not form a part of this specification document.
- B. Electrical specifications and performance data contained in this specification document are based on Mini-Circuit's applicable established test performance criteria and measurement instructions.
- C. The parts covered by this specification document are subject to Mini-Circuits standard limited warranty and terms and conditions (collectively, "Standard Terms"); Purchasers of this part are entitled to the rights and benefits contained therein. For a full statement of the Standard Terms and the exclusive rights and remedies thereunder, please visit Mini-Circuits' website at [www.minicircuits.com/MCLStore/terms.jsp](http://www.minicircuits.com/MCLStore/terms.jsp)

