

*Xtra Long Life 100 million cycles*

# USB/Ethernet RF Switch Matrix RC-2SP6T-A12

50Ω DC to 12 GHz

## The Big Deal

- **USB or Ethernet-TCP/IP** (HTTP and Telnet protocols) control
- Capable of 100 million cycles
- Two SP6T electromechanical, absorptive RF switches (90 dB typ. isolation)
- Plug-and-Play usable with Windows®, Mac®, and Linux® computers

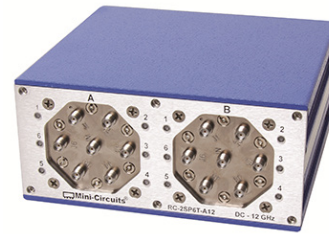

Case Style: PF2018



Installation CD

## Product Overview

Mini-Circuits' RC-2SP6T-A12 is a general purpose RF switch matrix controlled via either USB or Ethernet-TCP/IP (supports HTTP and Telnet protocols). The model contains two electromechanical SP6Ts, absorptive fail-safe RF switches constructed in break-before-make configuration and powered by +24VDC with switching time of 25 ms typical. The RF switches can be operated remotely using the supplied GUI software or programmed by the user with the included API objects. The RF switches operate over a wide frequency band from DC to 12 GHz, have low insertion loss (0.2 dB typical) and high isolation (90 dB typical) making the switch matrix perfectly suitable for a wide variety of RF applications.

The RC-2SP6T-A12 is constructed in a compact, rugged metal case (5.5" x 6.0" x 2.75") with 14 SMA(F) connectors (COM and ports 1 to 6 for each switch), a 2.1 mm DC socket, USB type B port, and a standard RJ45 network socket. The model is supplied with our easy-to-install, easy-to-use GUI software and API objects for Windows environments with complete programming instructions for 32 and 64 bit Windows® and Linux® operating systems. Also included is a 2.7 ft. USB cable, a 5 ft. Ethernet cable for Ethernet (HTTP and Telnet) control, and a power adaptor suitable for US, EU, and other power systems. See page 7 for list of all accessories included. Longer USB cables and a mounting bracket are available as additional accessories.

## Key Features

Feature	Advantages
Ethernet-TCP/IP- HTTP and Telnet Protocols (Supports DHCP and Static IP)	The RC-2SP6T-A12 switch matrix can be controlled from any Windows®, Mac®, or Linux® computer, or even a mobile device with a network connection and Ethernet-TCP/IP (HTTP or Telnet protocols) support. Using a VPN would allow remote control from anywhere in the world.
USB HID (Human Interface Device)	User may also control the switch matrix via USB connection. Plug-and-Play, no driver required. Compatible with Windows® or Linux® operating systems using 32 and 64 bit architecture.
RF SP6T absorptive electromechanical switches	Wideband (DC to 12 GHz) with low insertion loss (0.2 dB typ.), very high isolation (90 dB typ.), and high power rating (1W hot switching and 10W cold switching).
24VDC operating voltage	The RC-2SP6T-A12 requires 24V / 230 mA to power the RF switch, supplied from the power adaptor (included).
GUI Software CD, programming instructions, USB & Ethernet cables, and 24VDC power adaptor included	The RC-2SP6T-A12 comes ready to use out of the box with all software, accessories, and instructions needed for immediate operation included.
Switch Cycle Counters with automatic Calibration interval alerts	Allows user to monitor the exact usage of each switch and plan calibrations based on actual usage, improving reliability and saving maintenance costs.



Xtra Long Life 100 million cycles

# USB/Ethernet RF Switch Matrix RC-2SP6T-A12

50Ω DC to 12 GHz

## Features

- Capable of 100 million cycles
- Two DC to 12 GHz SP6T absorptive fail-safe RF switch in break-before-make configuration
- Electromechanical switching (Isolation 90 dB typ.)
- High power handling, 10W
- USB or Ethernet-TCP/IP (HTTP and Telnet) control
- Switch Cycle Counters with automatic calibration interval alerts
- Easy installation and operation
- Supports a wide range of programming environments (See [AN-49-001](#) for details)<sup>1</sup>
- Mounting bracket (Optional)
- Protected by US Patents 5,272,458; 6,414,577; 6,650,210; 7,633,361 and 7,843,289

## Applications

- R&D
- Automated Test equipment
- Controlling RF signal paths

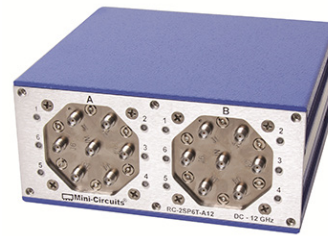

Case Style: PF2018



Installation CD

Model No.	Description	Qty.
<b>RC-2SP6T-A12</b>	<b>USB/Ethernet RF Switch</b>	1
<b>Included Accessories</b>		
AC/DC-24-3W1	AC/DC 24V Adapter (see Ordering Information)	1
CBL-3W1-XX	AC Power Cord (see Ordering Information)	1
USB-CBL-AB-3+	2.7 ft USB cable	1
CBL-RJ45-MM-5+	5 ft. Ethernet cable	1
RFSW-CD	Installation CD	1

**+RoHS Compliant**  
The +Suffix identifies RoHS Compliance. See our web site for RoHS Compliance methodologies and qualifications

## Mini-Circuits RF Switch Control Program for **USB/Ethernet** RF Switch Matrix

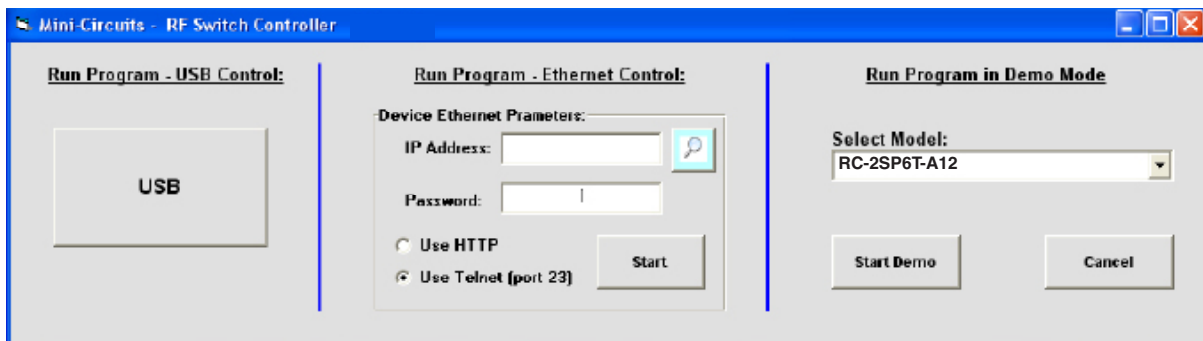

### Steps to start RC-2SP6T-A12 GUI via USB

- Click on USB button.
- If more than one unit is connected select S/N from list and click OK.
- Start working.

### Steps to start RC-2SP6T-A12 GUI via Ethernet

- Click on search icon.
- Select unit from list of IP addresses and click select
- The selected IP will appear in the IP Address field.
- Select communication protocol (Telnet or HTTP)
- Click on Start and begin working.

- For Demo mode of any Switch Matrix model select the model name from the drop box and click 'Start Demo' (See [user guide](#) for details)
- For programming instructions of the switch matrix see [programming guide](#) and [AN-49-001](#) on Mini-Circuits' website

<sup>1</sup> Windows is a registered trademarks of Microsoft Corporation in the United States and other countries. Linux is a registered trademark of Linus Torvalds. Mac is a registered trademark of Apple Corporation in the United States and other countries.

Neither Mini-Circuits nor the Mini-Circuits RC-2SP6T-A12 are affiliated with or endorsed by the owners of the above referenced trademarks.

Mini-Circuits and the Mini-Circuits logo are registered trademarks of Scientific Components Corporation.

## Electrical Specifications

Parameter	Port	Conditions	Min.	Typ.	Max.	Units
Rated Voltage	24V <sub>DC</sub> IN	provided via external power adapter	23	24	25	V
	USB Port	-	-	5	-	
<b>Power On Sequence: Connect the 24V power, followed by the USB control and/or Ethernet cable before turning on the Switch Matrix.</b>						
Rated Current	24V <sub>DC</sub> IN	COM -> 1,2,3,4,5 or 6 state	-	160	230	mA
		RF Switch @ Disconnect state	-	60	90	
	USB Port	COM -> 1,2,3,4,5 or 6 state	-	10	20	
		RF Switch @ Disconnect state	-	10	20	
Switching Time		-	-	25	-	ms
Life (per switch) <sup>2,6</sup>		@ 100 mW (hot switching) <sup>3</sup>	-	100	-	million switching cycles
		@ 1 W (hot switching) <sup>3</sup>	-	3	-	
RF Power (cold switching) <sup>4</sup>			-	-	10	W
RF VSWR <sup>5</sup>		DC to 1 GHz	-	1.05	1.10	:1
		1 GHz to 6 GHz	-	1.10	1.25	
		6 GHz to 8 GHz	-	1.20	1.35	
		8 GHz to 12 GHz	-	1.20	1.35	
RF Insertion Loss (per switch)		DC to 1 GHz	-	0.10	0.15	dB
		1 GHz to 6 GHz	-	0.15	0.25	
		6 GHz to 8 GHz	-	0.20	0.30	
		8 GHz to 12 GHz	-	0.25	0.35	
RF Isolation (per switch)		DC to 1 GHz	85	100	-	dB
		1 GHz to 6 GHz	80	95	-	
		6 GHz to 8 GHz	80	90	-	
		8 GHz to 12 GHz	80	90	-	

<sup>2</sup> Capable of up to 100 million cycles with proper maintenance, contact Mini-Circuits

<sup>3</sup> Exceeding these limits will result in reduced life.

<sup>4</sup> Power handling is specified with RF applied to the COM port and output load connected to 1,2,3, 4, 5 or 6 ports.

<sup>5</sup> For COM port only when connected to port 1,2,3, 4, 5 or 6. For ports 1,2,3, 4, 5 or 6 only when connected to COM port.

<sup>6</sup> Since these are mechanical devices, a lubrication may be required to meet the expected lifetimes shown in the specifications. Please see Mini-Circuits' warranty policy regarding these devices

## Minimum System Requirements

Interface	USB HID or HTTP Get/Post or Telnet protocols
Host operating system - USB Control	<b>Windows 32/64 Bit operating system:</b> Windows 98®, Windows XP®, Windows Vista®, Windows 7®, Windows 8® <b>Linux® support:</b> 32/64 Bit operating system
Host operating system - Ethernet Control	Any Windows®, Mac®, or Linux® computer with a network port and Ethernet-TCP/IP (HTTP or Telnet protocols) support
Hardware	Pentium® II or better <sup>5</sup>

<sup>5</sup> Pentium® is a registered trademark of Intel Corporation

## Connections

24V <sub>DC</sub> IN	(2.1 mm center positive DC Socket)
RF Switch A (All ports)	(SMA female)
RF Switch B (All ports)	(SMA female)
USB	(USB type B receptacle)
Network (Ethernet/LAN)	(RJ45 socket)

## Absolute Maximum Ratings

Operating Temperature	0°C to 40°C
Storage Temperature	-15°C to 45°C
DC Voltage max.	26V
RF power (at COM port of any switch)	10W
RF power (at 1 to 6 of any switch)	10W

Permanent damage may occur if any of these limits are exceeded.

## Outline Drawing (PF2018)

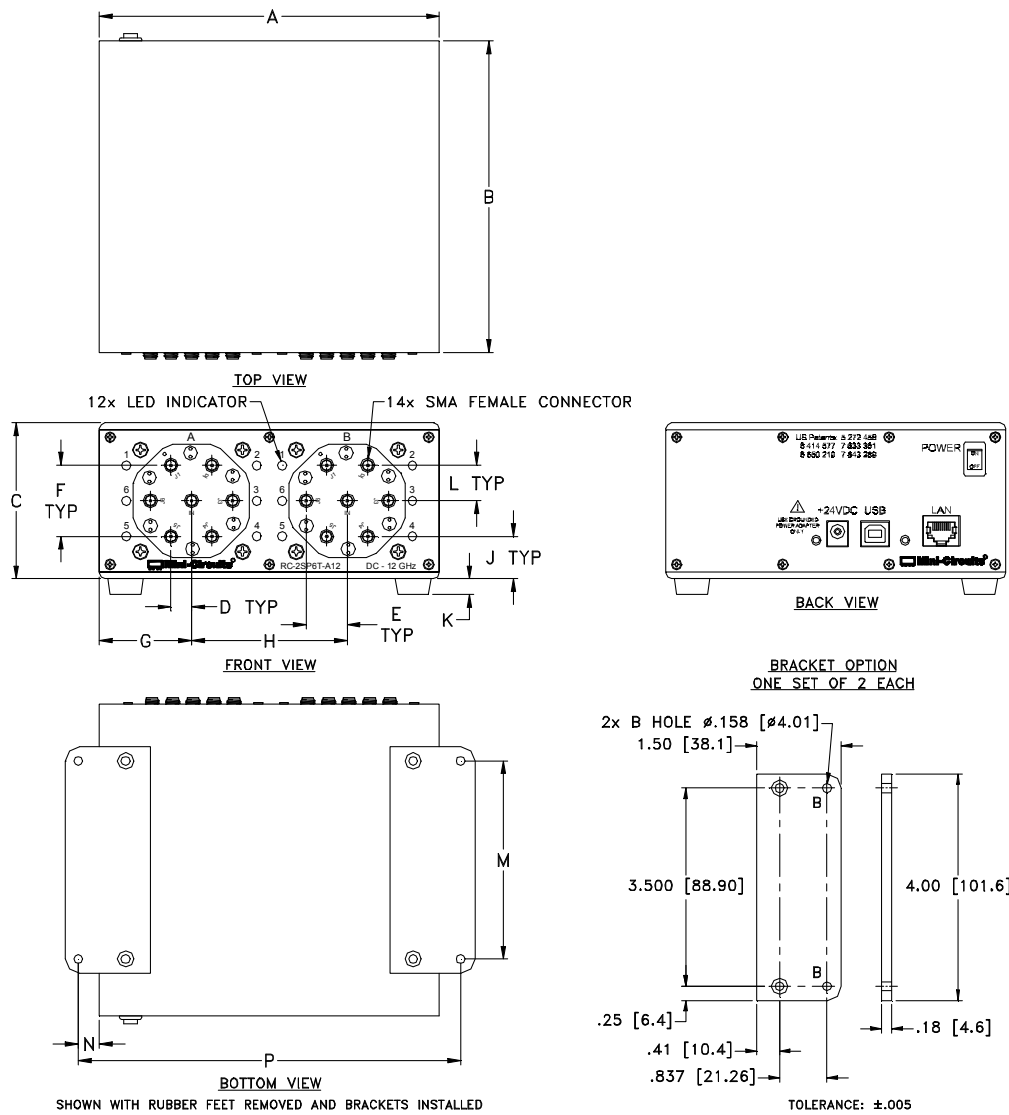

## Outline Dimensions ( inch mm )

A	B	C	D	E	F	G	H	J	K	L	M	N	P	wt
inch	inch	inch	inch	inch	inch	inch	inch	inch	inch	inch	inch	inch	inch	grams
6.00	5.50	2.75	0.36	0.73	1.26	1.63	2.75	0.75	0.28	0.63	3.50	0.375	6.72	grams
152.40	139.70	69.85	9.14	18.54	32.00	41.40	69.85	19.05	7.11	16.00	88.90	9.53	170.69	1350

## Main Software Control Screen: Independent control of two SP6T switches

- Power handling is specified with RF applied to the COM port and output load connected to either 1,2,3,4,5 or 6 of the respective switch.
- When connecting a coaxial semi flex cable, tighten connectors alternately using an 8in/lb torque wrench to insure proper contact at each end.

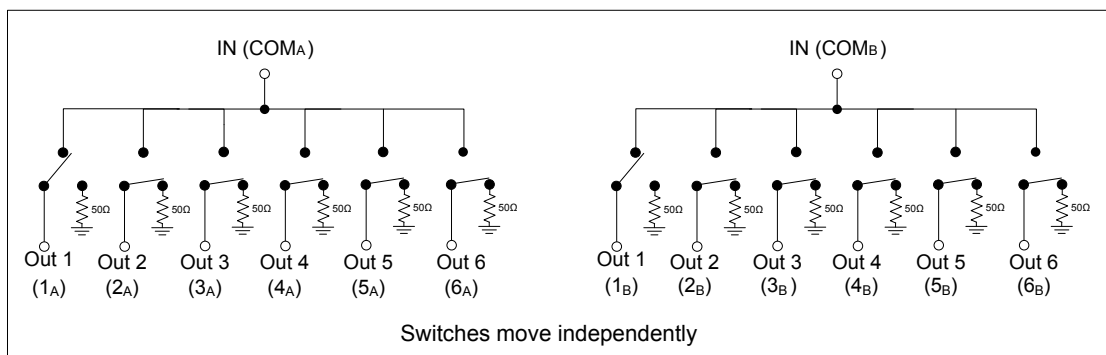
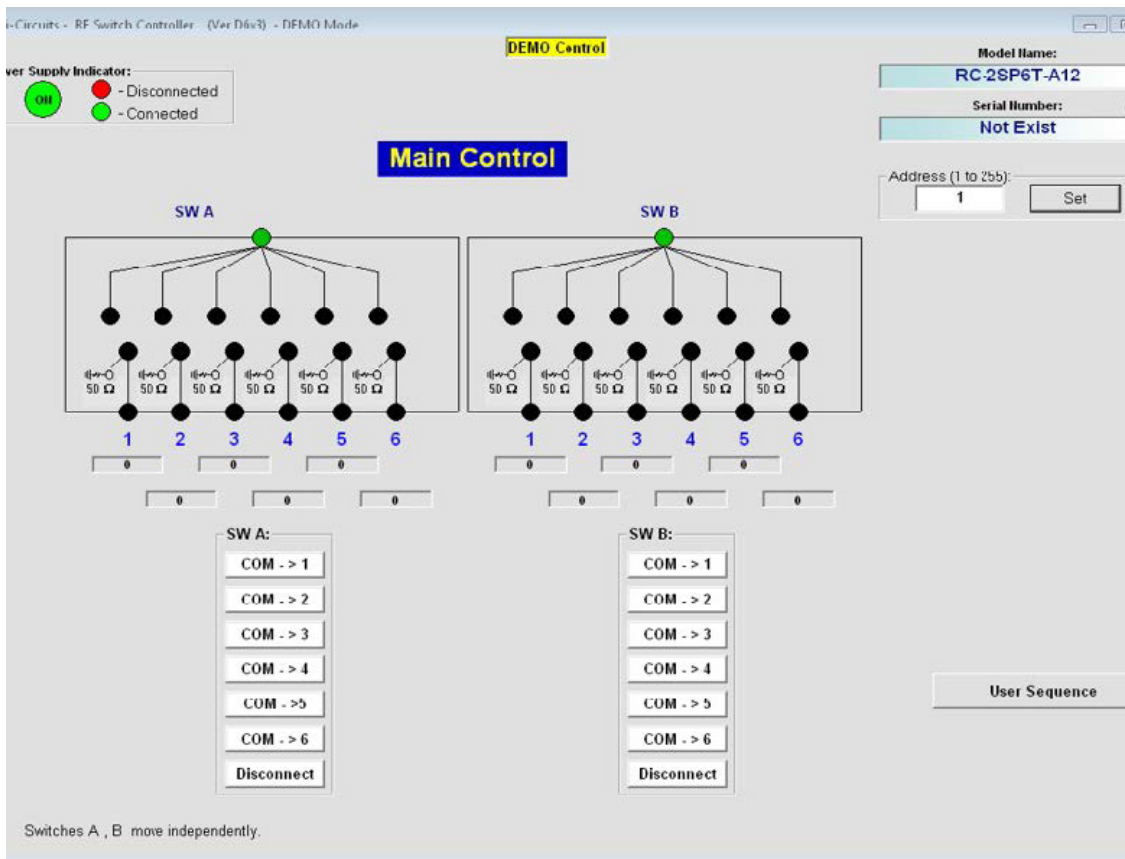



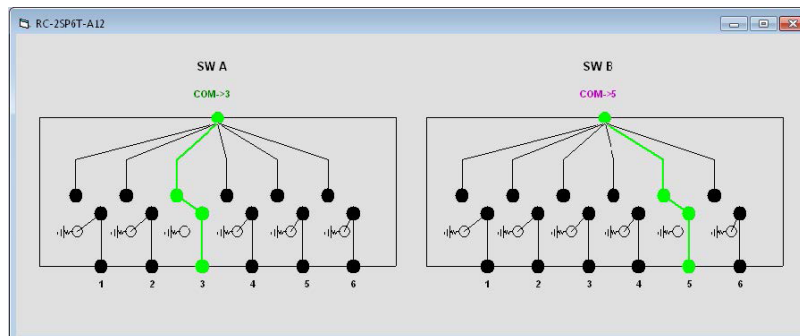
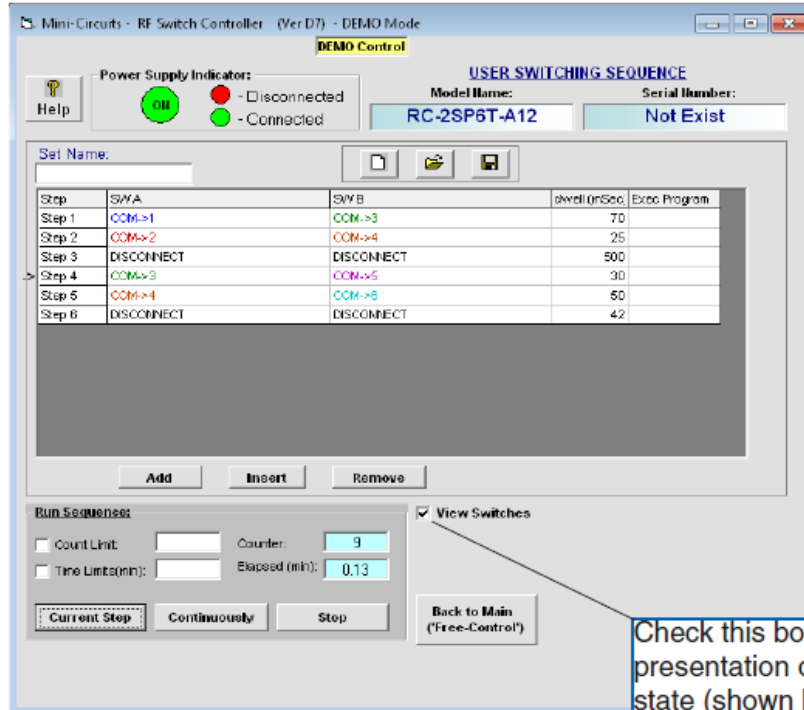

## User Switching Sequence - for setting an automated switch routine





- Power handling is specified with RF applied to the COM port and output load connected to either 1,2,3,4,5 or 6 of the respective switch.
- When connecting a coaxial semi flex cable, tighten connectors alternately using an 8in/lb torque wrench to insure proper contact at each end.



Ordering, Pricing & Availability Information see our web site

Model	Description
RC-2SP6T-A12	USB/Ethernet RF SP6T Switch Matrix

Included Accessories	Part No.	Description
	AC/DC-24-3W1	AC/DC 24V <sub>DC</sub> Grounded Power Adaptor. Operating temperature: 0°C to +40°C, I <sub>Max</sub> =2.5A
	CBL-3W1-XX	AC Power Cord (Select one power cord from below with each Switch Matrix box)
	RFSW-CD	Software CD
	USB-CBL-AB-3+	2.7 ft (0.8 m) USB Cable: USB type A(Male) to USB type B(Male)
	CBL-RJ45-MM-5+	5 ft (1.5 m) Ethernet cable: RJ45(Male) to RJ45(Male) Cat 5E cable

AC Power Cords <sup>7</sup>	Part No.	Description
	CBL-3W1-US	Power Cord for United States
	CBL-3W1-EU	Power Cord for Europe
	CBL-3W1-UK	Power Cord for United Kingdom
	CBL-3W1-AU	Power Cord for Australia and China
	CBL-3W1-IL	Power Cord for Israel

<sup>7</sup> Power cords for other countries are also available, if you need a power cord for a country not listed in the table please contact [apps@minicircuits.com](mailto:apps@minicircuits.com) or check <http://www.minicircuits.com/contact/offices.html> for regional offices e-mail and phone numbers.

Optional Accessories	Description
USB-CBL-3+ (spare)	2.7 ft (0.8 m) USB Cable: USB type A(Male) to USB type B(Male)
USB-CBL-7+	6.8 ft (2.1 m) USB Cable: USB type A(Male) to USB type B(Male)
USB-CBL-11+	11 ft (3.4 m) USB Cable: USB type A(Male) to USB type B(Male)
CBL-RJ45-MM-5+ (spare)	5 ft (1.5 m) Ethernet cable: RJ45(Male) to RJ45(Male) Cat 5E cable
BKT-272-08+	Bracket (One set of 2 each)

### Additional Notes

- A. Performance and quality attributes and conditions not expressly stated in this specification document are intended to be excluded and do not form a part of this specification document.
- B. Electrical specifications and performance data contained in this specification document are based on Mini-Circuit's applicable established test performance criteria and measurement instructions.
- C. The parts covered by this specification document are subject to Mini-Circuits standard limited warranty and terms and conditions (collectively, "Standard Terms"); Purchasers of this part are entitled to the rights and benefits contained therein. For a full statement of the Standard Terms and the exclusive rights and remedies thereunder, please visit Mini-Circuits' website at [www.minicircuits.com/MCLStore/terms.jsp](http://www.minicircuits.com/MCLStore/terms.jsp)

