

Plug-In QPSK Modulator

QMC-1050

50Ω

800 to 1050 MHz

Maximum Ratings

Operating Temperature	-55°C to 100°C
Storage Temperature	-55°C to 100°C
Input power	100mW
Control current	40mA

Permanent damage may occur if any of these limits are exceeded.

Pin Connections

RF IN	13
RF OUT	2
CONTROL-1	4
CONTROL-2	1
ISOLATE (DO NOT USE)	9,12,16
GROUND	3,5,6,7,8,10,11,14,15
CASE GROUND	3,5,6,7,8,10,11,14,15

Features

- hermetically sealed metal case
- good phase and amplitude balance

Applications

- communications systems
- cellular
- military, hi-rel applications

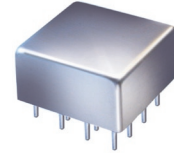

CASE STYLE: C07

PRICE: \$ 124.45 ea. QTY (1-9)

Modulator Electrical Specifications

MODEL NO.	FREQUENCY (MHz)	INSERTION LOSS (dB)		AMPLITUDE UNBALANCE (dB)		PHASE UNBALANCE (Deg.)± with reference to 90°		1 dB COMPR. (dBm)		VSWR (:1) Typ.	
		Typ.	Max.	Typ.	Max.	Typ.	Max.	Typ.	In	Out	
QMC-1050	800 1050	5.5	7.5	0.5	1.0	3	7	4	2.0	2.0	

All specifications at control current ±20mA.
Control ports drive with 50-ohm source.

Typical Performance Data

Freq. (MHz)	Insertion Loss		Amplitude Unbalance \bar{x} (dB)	Phase Unbalance (deg)			VSWR(:1)	
	\bar{x} (dB)	σ (dB)		90°	180°	-90°	IN \bar{x}	OUT \bar{x}
800.00	5.33	0.21	0.55	90.43	180.31	-90.46	1.20	1.45
806.50	5.34	0.20	0.55	90.65	180.30	-90.22	1.21	1.44
825.75	5.38	0.19	0.54	91.46	180.40	-89.37	1.25	1.41
846.75	5.44	0.17	0.51	92.33	180.55	-88.42	1.30	1.42
850.25	5.45	0.17	0.51	92.47	180.58	-88.31	1.30	1.43
867.75	5.51	0.16	0.49	92.89	180.73	-87.87	1.35	1.46
874.75	5.52	0.16	0.49	92.97	180.77	-87.76	1.37	1.48
888.75	5.56	0.15	0.48	93.03	180.87	-87.69	1.41	1.51
899.25	5.58	0.14	0.48	93.04	180.98	-87.67	1.43	1.53
908.00	5.60	0.14	0.47	93.07	181.08	-87.63	1.46	1.54
929.00	5.66	0.14	0.47	93.18	181.26	-87.56	1.51	1.55
950.00	5.70	0.14	0.46	93.17	181.36	-87.60	1.56	1.53
971.00	5.74	0.14	0.46	93.03	181.47	-87.78	1.61	1.53
992.00	5.79	0.14	0.48	92.84	181.53	-87.97	1.64	1.53
1000.75	5.81	0.14	0.49	92.76	181.57	-88.02	1.65	1.53
1011.25	5.84	0.14	0.51	92.66	181.59	-88.10	1.66	1.53
1025.25	5.87	0.14	0.55	92.50	181.62	-88.26	1.68	1.54
1032.25	5.88	0.15	0.57	92.42	181.67	-88.31	1.68	1.53
1049.75	5.91	0.15	0.61	92.10	181.72	-88.52	1.69	1.52
1050.00	5.92	0.14	0.62	92.04	181.75	-88.55	1.70	1.52

Outline Drawing

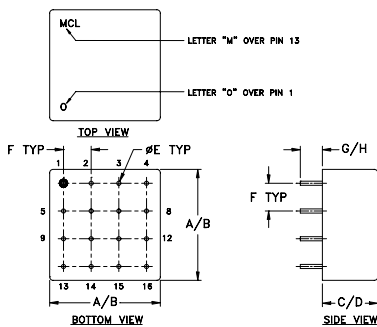

Outline Dimensions (inch/mm)

A	B	C	D	
.770	.810	.380	.410	.03
19.56	20.57	9.65	10.41	0.7

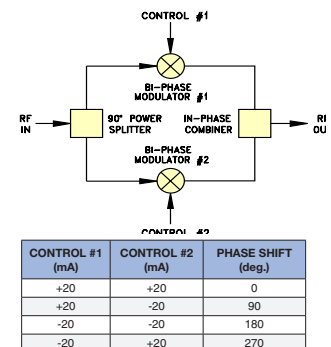
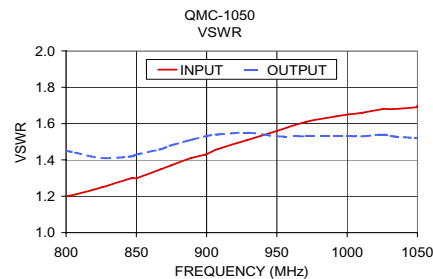
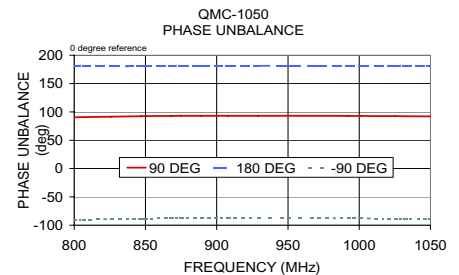
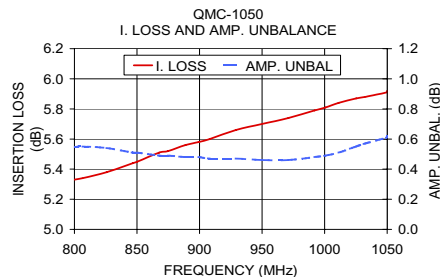

Mini-Circuits
ISO 9001 ISO 14001 AS 9100 CERTIFIED

P.O. Box 350166, Brooklyn, New York 11235-0003 (718) 934-4500 Fax (718) 332-4661 The Design Engineers Search Engine Provides ACTUAL Data Instantly at minicircuits.com

IF/RF MICROWAVE COMPONENTS

For detailed performance specs & shopping online see web site

Notes: 1. Performance and quality attributes and conditions not expressly stated in this specification sheet are intended to be excluded and do not form a part of this specification sheet. 2. Electrical specifications and performance data contained herein are based on Mini-Circuit's applicable established test performance criteria and measurement instructions. 3. The parts covered by this specification sheet are subject to Mini-Circuits standard limited warranty and terms and conditions (collectively, "Standard Terms"); Purchasers of this part are entitled to the rights and benefits contained therein. For a full statement of the Standard Terms and the exclusive rights and remedies thereunder, please visit Mini-Circuits' website at www.minicircuits.com/MCLStore/terms.jsp.

REV. OR
M97465
QMC-1050
DJ/VV/CP
070529