

Low Noise, High IP3

Monolithic Amplifier Die

PMA-545G1-D+

50Ω 0.4 to 2.2 GHz

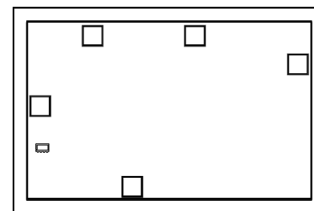

The Big Deal

- High Gain, 31.3 dB
- Low Noise Figure, 1.0 dB
- High IP3, 34-36 dBm

Product Overview

Mini-Circuits' PMA-545G1-D+ is a E-PHEMT based Low Noise MMIC Amplifier die operating from 0.4 to 2.2 GHz with a unique combination of low noise high gain and high IP3 making this amplifier ideal for sensitive receiver applications. This design operates on a single +5V supply and is internally matched to 50 Ohms.

Key Features

Feature	Advantages
High Gain: 26-32 dB	Incorporating multiple stages of amplification, the PMA-545G1-D+ provides high gain reducing cost and real estate.
Ultra Low Noise: 1.0 dB at 0.9 GHz	Excellent Noise Figure, measured in a 50 Ohm environment – without any external matching. When combined with high gain of this design, it suppresses second stage NF contribution.
High IP3: +35 dBm IP3 at 0.9 GHz	Combining Low Noise and High IP3 makes this MMIC amplifier ideal for Low Noise Receiver Front End (RFE) giving the user advantages at both ends of the dynamic range: sensitivity & two-tone IM dynamic range.
Output Power: +23 dBm at 0.9 GHz	The PMA-545G1-D+ maintains consistent output power capability over the full operating temperature range making it ideal to be used in remote applications such as LNB's as the L Band driver stage.
Internally Matched: 9-18 dB return loss	No external matching elements required to achieve the advertized noise and output power over the full band.
Max Input Power +25 dBm	Ruggedized design operates up to input powers often seen at Receiver inputs.
High Reliability	Low, small signal operating current of 160 mA nominal maintains junction temperatures typically below 123°C at 85°C at bottom of die.
Unpackaged Die	Enables user to integrate the amplifier directly into hybrids



Low Noise, High IP3

Monolithic Amplifier Die

PMA-545G1-D+

50Ω 0.4 to 2.2 GHz

Product Features

- High Gain, 31.3 dB typ. at 0.9 GHz
- Ultra Low Noise Figure, 1.0 dB typ. at 0.9 GHz
- High IP3, 34.6 dBm typ. 0.9 GHz
- Output Power, up to +23dBm typ. at 0.9 GHz
- Single Positive Supply Voltage, 5V

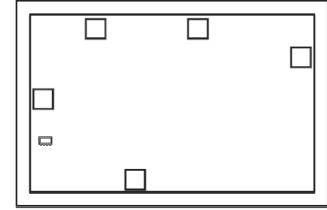

+RoHS Compliant

The +Suffix identifies RoHS Compliance. See our web site for RoHS Compliance methodologies and qualifications

Typical Applications

- Cellular
- ISM
- GSM
- WCDMA
- LTE
- GPS

Ordering Information: Refer to Last Page

General Description

PMA-545G1-D+ is a high dynamic range, low noise, high IP3, high output power, monolithic amplifier die. Manufactured using E-PHEMT* technology enables it to work with a single positive supply voltage. Unconditionally stable over the operating frequency.

Simplified Schematic and Pad description

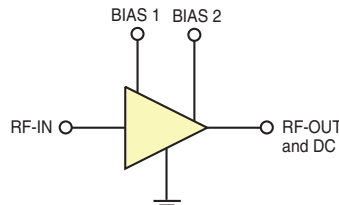

Bonding Pad	Description (See Application Circuit, Fig. 1)
RF-IN	RF input pad (connected to RF-IN via C1)
RF-OUT & DC	RF output pad (connected to RF-OUT via blocking external cap C2, and Supply voltage Vs via RF Choke L2)
BIAS 1	Connect to Vs
BIAS 2	Connect to Vs via L1
GROUND	Connected to ground

*Enhancement mode Pseudomorphic High Electron Mobility Transistor.

Electrical Specifications¹ at 25°C, Vd=5V, Zo=50Ω, (refer to characterization circuit)

Parameter	Condition (GHz)	Min.	Typ.	Max.	Units
Frequency Range		0.4		2.2	GHz
DC Voltage (Vd)		4.8	5.0	5.2	V
DC Current		117	158	186	mA
Noise Figure	0.4	—	1.2	—	dB
	0.9	—	1.0	—	
	1.2	—	1.0	—	
	1.6	—	1.1	—	
	2.2	—	1.3	—	
Gain	0.4	—	32.0	—	dB
	0.9	—	31.3	—	
	1.2	—	31.1	—	
	1.6	—	29.9	—	
	2.2	—	25.8	—	
Input Return Loss	0.4		15.8		dB
	0.9		9.4		
	1.2		10.0		
	1.6		12.9		
	2.2		18.1		
Output Return Loss	0.4		16.9		dB
	0.9		17.3		
	1.2		17.0		
	1.6		16.3		
	2.2		14.9		
Output IP3	0.4		34.5		dBm
	0.9		34.6		
	1.2		36.1		
	1.6		36.6		
	2.2		35.4		
Output Power @ 1 dB compression ²	0.4	—	22.2	—	dBm
	0.9	—	23.3	—	
	1.2	—	23.4	—	
	1.6	—	23.7	—	
	2.2	—	23.5	—	
DC Current Variation vs. Voltage			0.034		mA/mV
Thermal Resistance			40		°C/W

1. Measured on Mini-Circuits die Characterization test board.

See Characterization Test Circuit (Fig. 1)

2. Current increases at P1dB.

Absolute Maximum Ratings^{3,5}

Parameter	Ratings
Operating Temperature ⁴	-40°C to 85°C
Channel Temperature	150°C
DC Voltage (Pads Bias, RF-OUT & DC)	6V
Power Dissipation	1.35W
Input Power	25dBm

3. Permanent damage may occur if any of these limits are exceeded.

These maximum ratings are not intended for continuous normal operation.

4. Defined with reference to ground pad temperature.

5. Measured in industry standard 8-lead 3x3 MCLP package.

Characterization Test Circuit

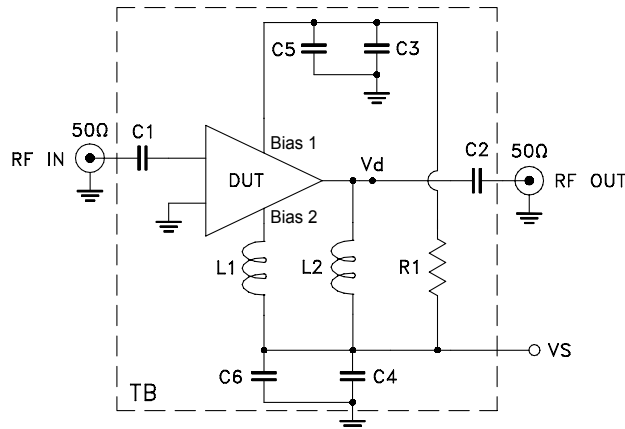

Recommended Application Circuit

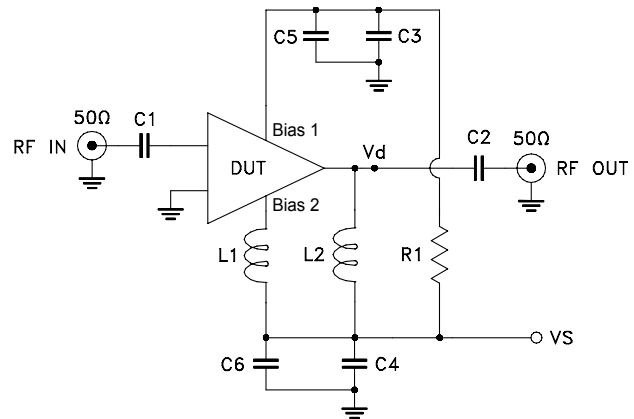

Fig 1. Block Diagram of Test Circuit used for characterization. Gain, Output power at 1dB compression (P1dB), Output IP3 (OIP3), Noise Figure are measured using Agilent's N5242A PNA-X microwave network analyzer.

Conditions:

1. Gain: Pin=-25 dBm
2. Output IP3 (OIP3): Two tones, spaced 1 MHz apart, 0 dBm/tone at output.
3. Vs adjusted for 5V at device (Vd), compensating loss of bias tee.

Component	Description
DUT	PMA-545G1-D+ Die
C1, C2, C5, C6	100 pF
C3, C4	1μF
R1	0 Ω
L1	36 nH
L2	47 nH

Die Layout

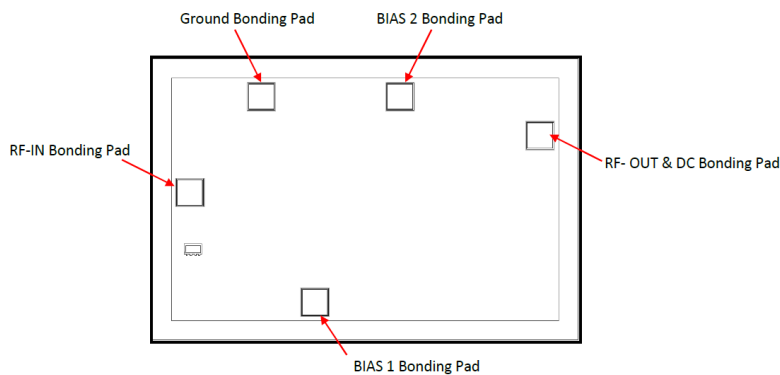

Fig 2. Die Layout

**Bonding Pad Position
(Dimensions in μm, Typical)**

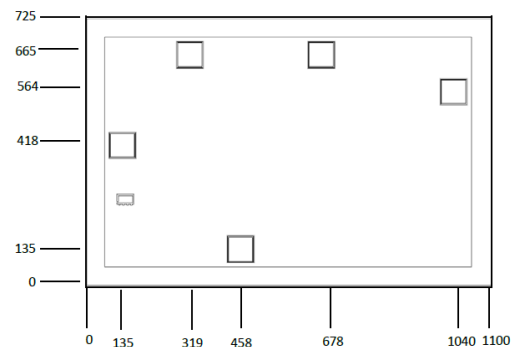

Fig 3. Bonding Pad Positions

Critical Dimensions

Parameter	Values
Die Thickness, μm	100
Die Width, μm	725
Die Length, μm	1100
Bond Pad Size, μm	75 x 75

Assembly and Handling Procedure

1. Storage
Dice should be stored in a dry nitrogen purged desiccators or equivalent.
2. ESD
MMIC Gallium Arsenide (GaAs) amplifier dice are susceptible to electrostatic and mechanical damage. Die are supplied in antistatic protected material, which should be opened in clean room conditions at an appropriately grounded anti-static workstation. Devices need careful handling using correctly designed collets, vacuum pickup tips or sharp antistatic tweezers to deter ESD damage to dice.
3. Die Attach
The die mounting surface must be clean and flat. Using conductive silver filled epoxy, recommended epoxies are DieMat DM6030HK-PT/H579 or Ablestik 84-1LMISR4. Apply sufficient epoxy to meet required epoxy bond line thickness, epoxy fillet height and epoxy coverage around total die periphery. Parts shall be cured in a nitrogen filled atmosphere per manufacturer's cure condition. It is recommended to use antistatic die pick up tools only.
4. Wire Bonding
Bond pad openings in the surface passivation above the bond pads are provided to allow wire bonding to the dice gold bond pads. Thermosonic bonding is used with minimized ultrasonic content. Bond force, time, ultrasonic power and temperature are all critical parameters. Suggested wire is pure gold, 1 mil diameter. Bonds must be made from the bond pads on the die to the package or substrate. All bond wires should be kept as short as low as reasonable to minimize performance degradation due to undesirable series inductance.

Assembly Diagram

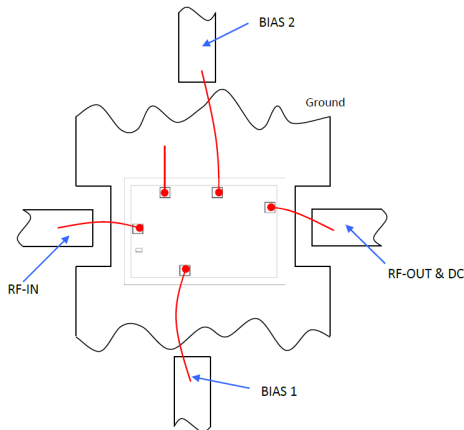

Recommended Wire Length, Typical

Wire	Wire Length (mm)	Wire Loop Height (mm)
RF-IN, RF-OUT & DC	0.8	0.15
BIAS 1, BIAS 2	1.2	0.15
GROUND	0.50	0.15

RF Reference Plane - No port extension

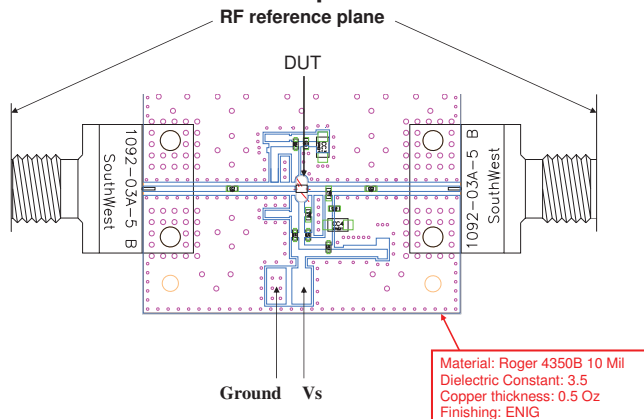

Additional Detailed Technical Information <i>additional information is available on our dash board.</i>	
Performance Data	Data Table
	Swept Graphs
	S-Parameter (S2P Files) Data Set with and without port extension(.zip file)
Case Style	Die
Die Ordering and packaging information	Quantity, Package Model No.
	Small, Gel - Pak: 10,50,100 KGD* PMA-545G1-DG+ Medium†, Partial wafer: KGD*<5K PMA-545G1-DP+ Large†, Full Wafer PMA-545G1-DF+
	† Available upon request contact sales representative
	Refer to AN-60-067
Environmental Ratings	ENV-80

*Known Good Dice (“KGD”) means that the dice in question have been subjected to Mini-Circuits DC test performance criteria and measurement instructions and that the parametric data of such dice fall within a predefined range. While DC testing is not definitive, it does help to provide a higher degree of confidence that dice are capable of meeting typical RF electrical parameters specified by Mini-Circuits.

ESD Rating**

Human Body Model (HBM): Class 1B (500 to <1000V) in accordance with ANSI/ESD STM 5.1 - 2001

Machine Model (MM): Class M1 (passed 40V) in accordance with ANSI/ESD STM5.2-1999

** Tested in industry standard 3x3mm, 8-lead, MCLP package.

Additional Notes

- A. Performance and quality attributes and conditions not expressly stated in this specification document are intended to be excluded and do not form a part of this specification document.
- B. Electrical specifications and performance data contained in this specification document are based on Mini-Circuit's applicable established test performance criteria and measurement instructions.
- C. The parts covered by this specification document are subject to Mini-Circuits standard limited warranty and terms and conditions (collectively, “Standard Terms”); Purchasers of this part are entitled to the rights and benefits contained therein. For a full statement of the Standard Terms and the exclusive rights and remedies thereunder, please visit Mini-Circuits’ website at www.minicircuits.com/MCLStore/terms.jsp
- D. Mini-Circuits does not warrant the accuracy or completeness of the information, text, graphics and other items contained within this document and same are provided as an accommodation and on an “As is” basis, with all faults.
- E. Purchasers of this part are solely responsible for proper storing, handling, assembly and processing of Known Good Dice (including, without limitation, proper ESD preventative measures, die preparation, die attach, wire bonding and related assembly and test activities), and Mini-Circuits assumes no responsibility therefor or for environmental effects on Known Good Dice.
- F. Mini-Circuits and the Mini-Circuits logo are registered trademarks of Scientific Components Corporation d/b/a Mini-Circuits. All other third-party trademarks are the property of their respective owners. A reference to any third-party trademark does not constitute or imply any endorsement, affiliation, sponsorship, or recommendation by any such third-party of Mini-Circuits or its products.

