

# Dual Matched MMIC Amplifier

PHA-22+

50Ω 0.05 to 1.5 GHz



CASE STYLE: DL1020

## The Big Deal

- Dual matched amplifier for push-pull & balanced amplifiers
- High IP2 and IP3
- May be used as a replacement to WJ AH22<sup>a,b</sup>

## Product Overview

Mini-Circuits PHA-22+ is a dual matched wideband amplifier fabricated using advanced E-PHEMT technology, offering high dynamic range (High IP3 and Low NF) for use in 50 and 75 ohm applications. Exceptionally high IP2 has been demonstrated in wideband 50 and 75 ohm amplifiers evaluation boards. Combining this with low noise figure to enable it for use in exceptionally high dynamic range amplifiers.

## Key Features

Feature	Advantages
Broadband	Covers Cable TV band and communication bands such as Cellular, Cable TV, PCS, WiMAX etc.
Matched pair for use in exceptionally high IP2 amplifiers	Typical gain match of 0.2 dB and phase match of 1.6 deg. enables it to be used in push-pull amplifiers. Outstanding IP2.
High IP3, up to 43 dBm	Ideal for suppressing unwanted intermods in the presence of multi carriers, which is common in present day communication systems.
Low Noise Figure: 1.8 dB typical	Compare this to the competitors, which is in the range of 4-6 dB. Mini-Circuits amplifier improves the dynamic range.
High P1dB: 22 dBm	High P1dB enables the amplifier to operate in linear region in the presence of strong interfering signals.

a. Suitability for model replacement within a particular system must be determined by and is solely the responsibility of the customer based on, among other things, electrical performance criteria, stimulus conditions, application, compatibility with other components and environmental conditions and stresses.

b. The WJ part number is used for identification and comparison purposes only.



For detailed performance specs & shopping online see web site

P.O. Box 350166, Brooklyn, New York 11235-0003 (718) 934-4500 Fax (718) 332-4661 The Design Engineers Search Engine  Provides ACTUAL Data Instantly at [minicircuits.com](http://minicircuits.com)

IF/RF MICROWAVE COMPONENTS

Notes: 1. Performance and quality attributes and conditions not expressly stated in this specification sheet are intended to be excluded and do not form a part of this specification sheet. 2. Electrical specifications and performance data contained herein are based on Mini-Circuit's applicable established test performance criteria and measurement instructions. 3. The parts covered by this specification sheet are subject to Mini-Circuits standard limited warranty and terms and conditions (collectively, "Standard Terms"); Purchasers of this part are entitled to the rights and benefits contained therein. For a full statement of the Standard Terms and the exclusive rights and remedies thereunder, please visit Mini-Circuits' website at [www.minicircuits.com/MCLStore/terms.jsp](http://www.minicircuits.com/MCLStore/terms.jsp).

Surface Mount

# Dual Matched MMIC Amplifier

.05-1.5 GHz

## Product Features

- Two matched amplifiers in one package
- High IP3, +44 dBm at 0.8 GHz in push-pull configuration
- High IP2, +78 dBm at 0.8 GHz in push-pull configuration
- Gain, 16 dB typ. at 0.8 GHz
- P1dB, +22 dBm typ. at 0.8 GHz
- Low noise figure, 1.8 dB typ. at 0.8 GHz
- May be used as replacement for WJ AH22<sup>a,b</sup>



## PHA-22+

CASE STYLE: DL1020  
 PRICE: \$7.95 ea. QTY. (10)

## Typical Applications

- CATV
- FTTH
- Optical networks
- Base station infrastructure
- Balanced amplifiers
- 75 Ohm push-pull and balanced amplifiers

**+ RoHS compliant in accordance with EU Directive (2002/95/EC)**

*The +Suffix has been added in order to identify RoHS Compliance. See our web site for RoHS Compliance methodologies and qualifications.*

## General Description

PHA-22+ is a dual matched wideband high dynamic range amplifier. Enclosed in a 6.0 x 4.9 mm MCLP plastic package. PHA-22+ is fabricated using E-PHEMT\* technology and is ideal for use in balanced and push-pull amplifiers.

### simplified schematic (each of A1, A2) and pin description

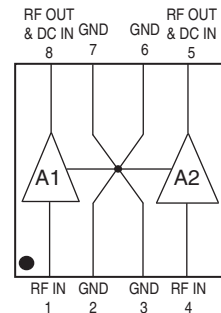
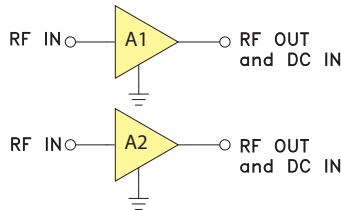

Function	Pin Number	Description
RF IN, A1	1	RF input pin. This pin requires the use of an external DC blocking capacitor chosen for the frequency of operation. (see Application Circuit, Fig 2.)
RF-OUT and DC-IN, A1	8	RF output and bias pin. DC voltage is present on this pin; therefore a DC blocking capacitor is necessary for proper operation. An RF choke is needed to feed DC bias without loss of RF signal due to the bias connection, as shown in "Recommended Application Circuit", Fig 2
RF IN, A2	4	RF input pin. This pin requires the use of an external DC blocking capacitor chosen for the frequency of operation. (see Application Circuit, Fig 2.)
RF-OUT and DC-IN, A2	5	RF output and bias pin. DC voltage is present on this pin; therefore a DC blocking capacitor is necessary for proper operation. An RF choke is needed to feed DC bias without loss of RF signal due to the bias connection, as shown in "Recommended Application Circuit", Fig 2
GND	2,3,6,7 & paddle	Connections to ground. Use via holes as shown in "Suggested Layout for PCB Design" to reduce ground path inductance for best performance.

\* Enhancement mode pseudomorphic High Electron Mobility Transistor.

a. Suitability for model replacement within a particular system must be determined by and is solely the responsibility of the customer based on, among other things, electrical performance criteria, stimulus conditions, application, compatibility with other components and environmental conditions and stresses.  
 b. The WJ part number is used for identification and comparison purposes only.



For detailed performance specs & shopping online see web site

P.O. Box 350166, Brooklyn, New York 11235-0003 (718) 934-4500 Fax (718) 332-4661 The Design Engineers Search Engine Provides ACTUAL Data Instantly at [minicircuits.com](http://minicircuits.com)

Notes: 1. Performance and quality attributes and conditions not expressly stated in this specification sheet are intended to be excluded and do not form a part of this specification sheet. 2. Electrical specifications and performance data contained herein are based on Mini-Circuit's applicable established test performance criteria and measurement instructions. 3. The parts covered by this specification sheet are subject to Mini-Circuits standard limited warranty and terms and conditions (collectively, "Standard Terms"); Purchasers of this part are entitled to the rights and benefits contained therein. For a full statement of the Standard Terms and the exclusive rights and remedies thereunder, please visit Mini-Circuits' website at [www.minicircuits.com/MCLStore/terms.jsp](http://www.minicircuits.com/MCLStore/terms.jsp).

REV. OR  
 M127612  
 PHA-22+  
 MCL NY  
 100817  
 Page 2

**Electrical Specifications<sup>1</sup> at 25°C, Zo=50Ω and Device Voltage 5V, unless noted**  
*(Specifications (other than Matching or where defined as push-pull) are for each of the two matched amplifiers in the package)*

Parameter	Condition (GHz)	Min.	Typ.	Max.	Units
Frequency Range		0.05		1.5	GHz
Gain	0.05		17.7		
	0.8	14.5	16.1	17.7	dB
	1.5		15.4		
Input Return Loss	0.05		11.3		dB
	0.8		17.0		
	1.5		11.7		
Output Return Loss	0.05		14.1		dB
	0.8		18.8		
	1.5		13.1		
Output Power @ 1 dB compression <sup>(2)</sup>	0.05		22.4		dBm
	0.8		22.5		
	1.5		22.5		
Output IP3 <sup>(6)</sup>	0.05		41.4		dBm
	0.8	37.0	41.5		
	1.5		42.9		
Noise Figure	0.05		1.8		dB
	0.8		1.8		
	1.5		2.0		
Matching between A1, A2	Amplitude Unbalance	0.05	0.11		
		0.8	0.12	0.6	dB
		1.5	0.22		
	Phase Unbalance	0.05	0.3		
		0.8	1.0	5.0	deg.
		1.5	1.6		
Device Operating Voltage		4.8	5.0	5.2	V
Device Operating Current (each amplifier)		110	146	180	mA
Device Current Variation vs. Temperature			23		μA/°C
Device Current Variation vs Voltage			0.053		mA/mV
Thermal Resistance, junction-to-ground lead, A1 or A2 <sup>(7)</sup>			34		°C/W

**Push-Pull Amplifier Typical Performance <sup>(3)</sup>**

Frequency		0.05	0.25	0.45	0.85	1.2	1.3	GHz
Gain	75Ω	14.2	13.7	14.0	14.1	13.8	13.5	dB
Output IP3		45	43	42	43	40.6	40.3	dBm
Output IP2		79	79	81	72	78	78	dBm
Gain	50Ω	15.2	13.8	13.8	13	12	—	dB
Output IP3		45	45	44	44	43	—	dBm
Output IP2		82	84	81	76	72	—	dBm

**Absolute Maximum Ratings <sup>(4)</sup>**

Parameter	Ratings
Operating Temperature <sup>(5)</sup>	-40°C to 85°C
Storage Temperature	-55°C to 150°C
Operating Current at 5V <sup>(6)</sup>	200 mA
Power Dissipation <sup>(6)</sup>	1000 mW
Input Power (CW)	+24
DC Voltage (pads 5,8)	6V

Notes:

- (1) Measured on Mini-Circuits Test Board TB-561+ (characterization test circuit, Fig 1a).
- (2) Current increases at P1dB
- (3) Measured on evaluation boards (push-pull amplifiers) TB-566-50+ (50Ω) and TB-566-75+ (75Ω). See Characterization Test Circuit (Fig. 1b)
- (4) Permanent damage may occur if any of these limits are exceeded. These ratings are not intended for continuous normal operation.
- (5) Defined with reference to ground pad temperature.
- (6) Per single ended amplifier
- (7)  $\Theta_{jc} = \frac{\text{Junction Temperature} - 85^\circ\text{C}}{\text{Voltage X sum of current in A1 \& A2}}$



For detailed performance specs & shopping online see web site

P.O. Box 350166, Brooklyn, New York 11235-0003 (718) 934-4500 Fax (718) 332-4661 The Design Engineers Search Engine Provides ACTUAL Data Instantly at [minicircuits.com](http://minicircuits.com)

Notes: 1. Performance and quality attributes and conditions not expressly stated in this specification sheet are intended to be excluded and do not form a part of this specification sheet. 2. Electrical specifications and performance data contained herein are based on Mini-Circuit's applicable established test performance criteria and measurement instructions. 3. The parts covered by this specification sheet are subject to Mini-Circuits standard limited warranty and terms and conditions (collectively, "Standard Terms"); Purchasers of this part are entitled to the rights and benefits contained therein. For a full statement of the Standard Terms and the exclusive rights and remedies thereunder, please visit Mini-Circuits' website at [www.minicircuits.com/MCLStore/terms.jsp](http://www.minicircuits.com/MCLStore/terms.jsp).

Characterization Test Circuit

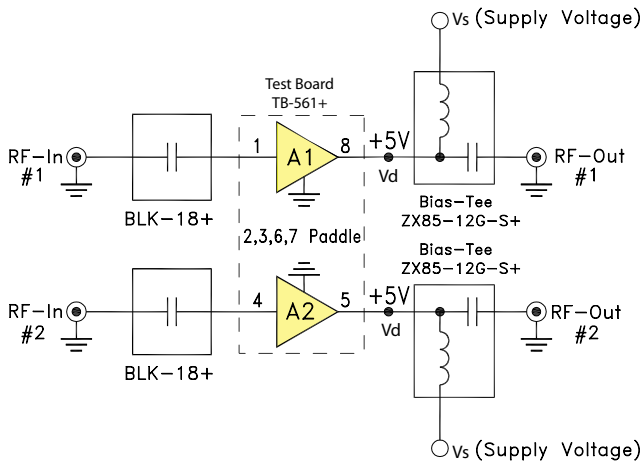

**Fig 1a.** Block Diagram of Test Circuit used for characterization. (DUT tested in Mini-Circuits Test board TB-561+, except for IP2) Gain, Return loss, Output power at 1dB compression (P1 dB) , output IP3 (OIP3) and noise figure measured using Agilent’s N5242A PNA-X microwave network analyzer.

**Conditions:**

1. Gain and Return loss: Pin= -25dBm
2. Output IP3 (OIP3): Two tones, spaced 1MHz apart, 5 dBm/tone at output.

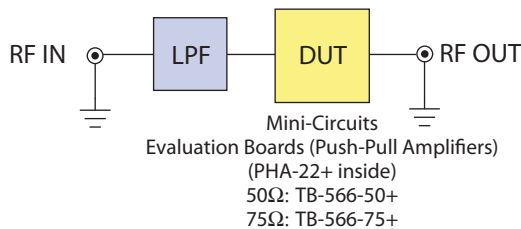
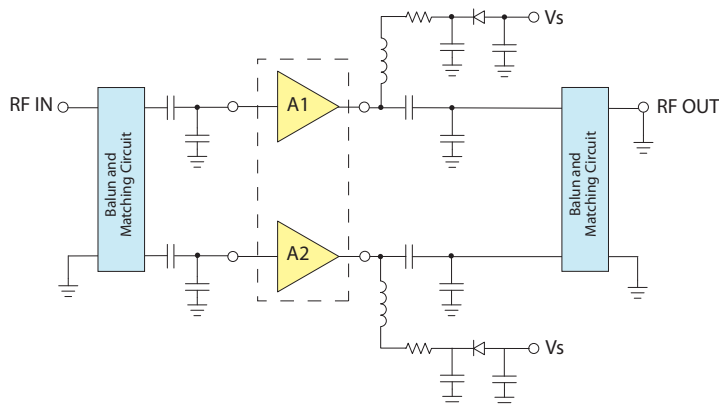

**Fig 1b.** Block Diagram of Test Set up used for characterization of Gain, IP2, IP3. Measured using Agilent’s signal generators E8527D and Spectrum analyzer N9020A.

**Conditions:**

1. Two tones, spaced 1MHz apart, 5 dBm/tone at output. IP2 is measured at the sum frequency of the tones.

Recommended Application Circuit



**Fig 2.** Recommended Application Circuit. Refer to following Mini-Circuits Evaluation Boards for parts list.  
50Ω: TB-566-50+  
75Ω: TB-566-75+

**Product Marking**

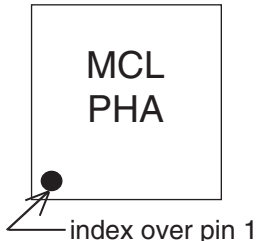

Additional Detailed Technical Information <i>(additional information is available on our web site. To access this information enter the model number on our web site home page)</i>		
<b>Performance Data</b>	Data Table	
	Swept Graphs	
	S-Parameter (S2P Files) Data Set (.zip file)	
<b>Case Style</b>	DL1020 <i>Plastic package, exposed paddle, lead finish: tin/silver/nickel</i>	
<b>Tape &amp; Reel</b>	F68	
<b>Suggested Layout for PCB Design</b>	PL-322	
<b>Evaluation Board</b>	<a href="#">TB-566-50+ (50Ω, 0.05-1.2 GHz)</a> <a href="#">TB-566-75+ (75Ω, 0.05-1.3 GHz)</a>	
<b>Environmental Ratings</b>	ENV08T2	

**ESD Rating**

Human Body Model (HBM): Class 1A ( 250 to <500V) in accordance with ANSI/ESD STM 5.1 - 2001  
 Machine Model (MM): Class M1 (25V) in accordance with ANSI/ESD STM5.2-1999

**MSL Rating**

Moisture Sensitivity: MSL1 in accordance with IPC/JEDEC J-STD-020D

**MSL Test Flow Chart**

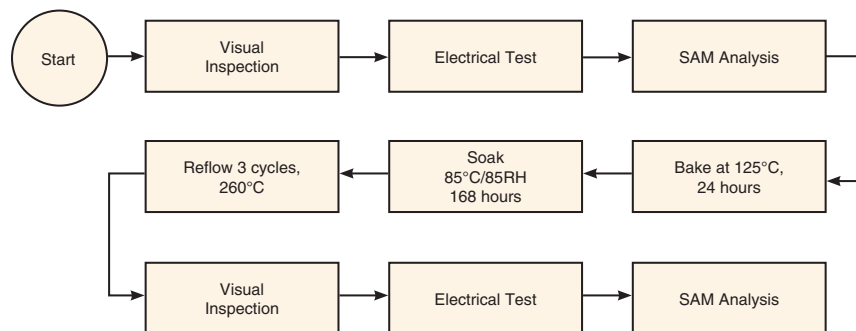

For detailed performance specs & shopping online see web site

P.O. Box 350166, Brooklyn, New York 11235-0003 (718) 934-4500 Fax (718) 332-4661 The Design Engineers Search Engine Provides ACTUAL Data Instantly at [minicircuits.com](http://minicircuits.com)

**Notes:** 1. Performance and quality attributes and conditions not expressly stated in this specification sheet are intended to be excluded and do not form a part of this specification sheet. 2. Electrical specifications and performance data contained herein are based on Mini-Circuit's applicable established test performance criteria and measurement instructions. 3. The parts covered by this specification sheet are subject to Mini-Circuits standard limited warranty and terms and conditions (collectively, "Standard Terms"); Purchasers of this part are entitled to the rights and benefits contained therein. For a full statement of the Standard Terms and the exclusive rights and remedies thereunder, please visit Mini-Circuits' website at [www.minicircuits.com/MCLStore/terms.jsp](http://www.minicircuits.com/MCLStore/terms.jsp).