

Ultra High Dynamic Range

Monolithic Amplifier

PGA-102+

50Ω 0.05 to 6 GHz

The Big Deal

- High IP3
- Broadband High Dynamic Range without external Matching Components



SOT-89 PACKAGE

Product Overview

PGA-102+ (RoHS compliant) is an advanced wideband amplifier fabricated using E-PHEMT technology and offers extremely high dynamic range over a broad frequency range and with low noise figure. In addition, the PGA-102+ has good input and output return loss over a broad frequency range without the need for external matching components and has demonstrated excellent reliability. Lead finish is SnAgNi. It has repeatable performance from lot to lot and is enclosed in a SOT-89 package for very good thermal performance.

Key Features

Feature	Advantages
Broad Band: 0.05 to 6.0 GHz	Broadband covering primary wireless communications bands: Cellular, PCS, LTE, WiMAX
High IP3 Versus DC power Consumption: 33 dBm typical at 2 GHz at +3.3V Supply Voltage and only 83mA	The PGA-102+ provides good IP3 performance relative to device size and power consumption. The combination of the design and E-PHEMT Structure provides enhanced linearity over a broad frequency range as evidence in the IP3 being typically 15 dB above the P 1dB point. This feature makes this amplifier ideal for use in: <ul style="list-style-type: none">• Driver amplifiers for complex waveform up converter paths• Drivers in linearized transmit systems• Secondary amplifiers in ultra High Dynamic range receivers
No External Matching Components Required	Unlike competing products, Mini-Circuits PGA-102+ provides Input and Output Return Loss of 16-19 dB up to 4 GHz without the need for any external matching components
Low Noise Figure: 2.3 dB up to 0.8 GHz	A unique feature of the PGA-102+ which separates this design from all competitors is the low noise figure performance in combination with the high dynamic range.



P.O. Box 350166, Brooklyn, New York 11235-0003 (718) 934-4500 Fax (718) 332-4661 The Design Engineers Search Engine  Provides ACTUAL Data Instantly at minicircuits.com

IFIRF MICROWAVE COMPONENTS

For detailed performance specs
& shopping online see web site

Notes: 1. Performance and quality attributes and conditions not expressly stated in this specification sheet are intended to be excluded and do not form a part of this specification sheet. 2. Electrical specifications and performance data contained herein are based on Mini-Circuit's applicable established test performance criteria and measurement instructions. 3. The parts covered by this specification sheet are subject to Mini-Circuits standard limited warranty and terms and conditions (collectively, "Standard Terms"); Purchasers of this part are entitled to the rights and benefits contained therein. For a full statement of the Standard Terms and the exclusive rights and remedies thereunder, please visit Mini-Circuits' website at www.minicircuits.com/MCLStore/terms.jsp.

Low Noise, High IP3

Monolithic Amplifier

0.05-6 GHz

Product Features

- 3.3V, 83mA operation
- High IP3, 33 dBm typ. at 2 GHz
- Gain, 14.0 dB typ. at 2 GHz
- P1dB 17.5 dBm typ. at 2 GHz
- Low noise figure, 2.4dB at 2 GHz
- No external matching components required

Typical Applications

- Base station infrastructure
- Portable Wireless
- CATV & DBS
- MMDS & Wireless LAN
- LTE



PGA-102+

CASE STYLE: DF782
PRICE: \$1.39 ea. QTY. (50)

+ RoHS compliant in accordance with EU Directive (2002/95/EC)

The +Suffix has been added in order to identify RoHS Compliance. See our web site for RoHS Compliance methodologies and qualifications.

General Description

PGA-102+ (RoHS compliant) is an advanced wideband amplifier fabricated using E-PHEMT technology and offers extremely high dynamic range over a broad frequency range and with low noise figure. In addition, the PGA-102+ has good input and output return loss over a broad frequency range without the need for external matching components. Lead finish is SnAgNi. It has repeatable performance from lot to lot and is enclosed in a SOT-89 package for very good thermal performance.

simplified schematic and pin description

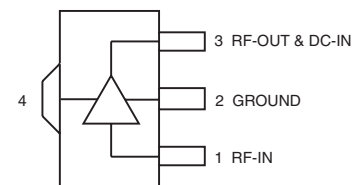
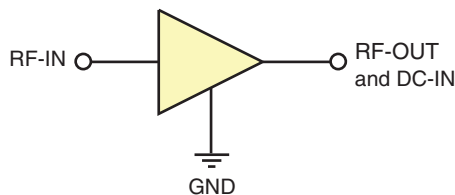

Function	Pin Number	Description
RF IN	1	RF input pin. This pin requires the use of an external DC blocking capacitor chosen for the frequency of operation.
RF-OUT and DC-IN	3	RF output and bias pin. DC voltage is present on this pin; therefore a DC blocking capacitor is necessary for proper operation. An RF choke is needed to feed DC bias without loss of RF signal due to the bias connection, as shown in "Recommended Application Circuit", Fig. 2
GND	2,4	Connections to ground. Use via holes as shown in "Suggested Layout for PCB Design" to reduce ground path inductance for best performance.



P.O. Box 350166, Brooklyn, New York 11235-0003 (718) 934-4500 Fax (718) 332-4661 The Design Engineers Search Engine Provides ACTUAL Data Instantly at minicircuits.com

IF/RF MICROWAVE COMPONENTS

For detailed performance specs & shopping online see web site

Notes: 1. Performance and quality attributes and conditions not expressly stated in this specification sheet are intended to be excluded and do not form a part of this specification sheet. 2. Electrical specifications and performance data contained herein are based on Mini-Circuit's applicable established test performance criteria and measurement instructions. 3. The parts covered by this specification sheet are subject to Mini-Circuits standard limited warranty and terms and conditions (collectively, "Standard Terms"); Purchasers of this part are entitled to the rights and benefits contained therein. For a full statement of the Standard Terms and the exclusive rights and remedies thereunder, please visit Mini-Circuits' website at www.minicircuits.com/MCLStore/terms.jsp.

REV. A
M131392
PGA-102+
TH/RS/CP
110406
Page 2

Electrical Specifications⁽¹⁾ at 25°C, 50Ω and 3.3V, unless noted

Parameter	Condition (GHz)	Min.	Typ.	Max.	Units
Frequency Range		0.05		6	GHz
Gain	0.05 0.8 2.0 3.0 4.0 6.0	14.4	17.7 15.9 14.0 12.5 11.5 10.4	17.4	dB
Input Return Loss	0.05 0.8 2.0 3.0 4.0 6.0	15	14.0 18.4 12.4 10.5 9.4 6.7		dB
Output Return Loss	0.05 0.8 2.0 3.0 4.0 6.0	15	18.3 18.6 17.6 17.1 15.3 11.0		dB
Reverse Isolation	2.0		21.9		dB
Output Power @ 1 dB compression	0.05 0.8 2.0 3.0 4.0 6.0	16.0	17.6 17.4 17.5 17.5 17.3 16.5		dBm
Output IP3	0.05 0.8 2.0 3.0 4.0 6.0		30.8 32.7 33.0 33.0 33.4 33.2		dBm
Noise Figure	0.05 0.8 2.0 3.0 4.0 6.0		2.1 2.3 2.4 2.8 3.0 3.9		dB
Device Operating Voltage		3.1	3.3	3.5	V
Device Operating Current		60	83	120	mA
Device Current Variation vs. Temperature			49		μA/°C
Device Current Variation vs Voltage			0.066		mA/mV
Thermal Resistance, junction-to-ground lead			73		°C/W

⁽¹⁾ Measured on Mini-Circuits Characterization test board TB-313. See Characterization Test Circuit (Fig. 1)

Absolute Maximum Ratings

Parameter	Ratings
Operating Temperature (ground lead)	-40°C to 85°C
Storage Temperature	-65°C to 150°C
Operating Current at 3.3V	300 mA
Power Dissipation	1.0 W
Input Power (CW)	28 dBm
DC Voltage on Pin 3	5.5 V

Note:

Permanent damage may occur if any of these limits are exceeded.

Electrical maximum ratings are not intended for continuous normal operation.



For detailed performance specs
& shopping online see web site

P.O. Box 350166, Brooklyn, New York 11235-0003 (718) 934-4500 Fax (718) 332-4661 The Design Engineers Search Engine  Provides ACTUAL Data Instantly at minicircuits.com

IF/RF MICROWAVE COMPONENTS

Notes: 1. Performance and quality attributes and conditions not expressly stated in this specification sheet are intended to be excluded and do not form a part of this specification sheet. 2. Electrical specifications and performance data contained herein are based on Mini-Circuit's applicable established test performance criteria and measurement instructions. 3. The parts covered by this specification sheet are subject to Mini-Circuits standard limited warranty and terms and conditions (collectively, "Standard Terms"); Purchasers of this part are entitled to the rights and benefits contained therein. For a full statement of the Standard Terms and the exclusive rights and remedies thereunder, please visit Mini-Circuits' website at www.minicircuits.com/MCLStore/terms.jsp.

Characterization Test Circuit

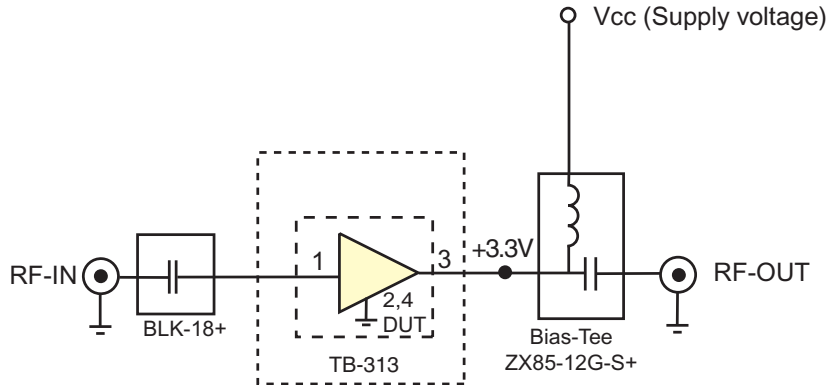
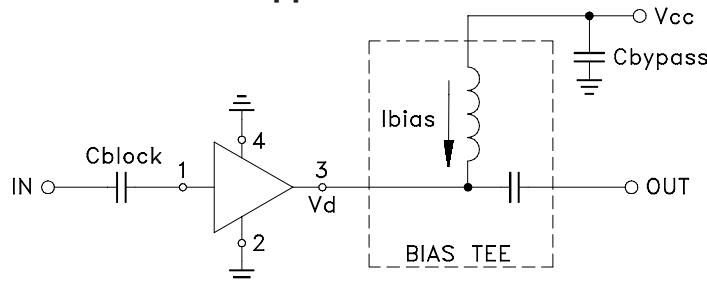

Fig 1. Block Diagram of Test Circuit used for characterization. (DUT tested on Mini-Circuits Characterization test board TB-313)
Gain, Return loss, Output power at 1dB compression (P1 dB) , output IP3 (OIP3) and noise figure measured using Agilent’s N5242A PNA-X microwave network analyzer.

Conditions:

1. Gain and Return loss: Pin= -25dBm
2. Output IP3 (OIP3): Two tones, spaced 10 MHz apart, 2.5 dBm/tone at output.

Recommended Application Circuit











Cblock=0.001µF, Bias-Tee=TCBT-14+, Cbypass=0.1µF

Fig 2. Evaluation board includes case, connectors, and components soldered to PCB

Product Marking



Additional Detailed Technical Information		
<i>(additional information is available on our web site. To access this information enter the model number on our web site home page)</i>		
Performance Data	Data Table	
	Swept Graphs	
	S-Parameter (S2P Files) Data Set (.zip file)	
Case Style	DF782 (SOT 89) <i>Plastic package, exposed paddle, lead finish: tin/silver/nickel</i>	
Tape & Reel Standard quantities available on reel	F55 <i>7" reels with 20, 50, 100, 200, 500, or 1K devices.</i>	
Suggested Layout for PCB Design	PL-313	
Evaluation Board	TB-596-1+	
Environmental Ratings	ENV08T1	

ESD Rating

Human Body Model (HBM): Class 1B (500 to <1000V) in accordance with ANSI/ESD STM 5.1 - 2001

Machine Model (MM): Class M1(50V) in accordance with ANSI/ESD STM5.2-1999



Attention
Observe precautions for handling electrostatic sensitive devices

MSL Rating

Moisture Sensitivity: MSL1 in accordance with IPC/JEDEC J-STD-020D

MSL Test Flow Chart

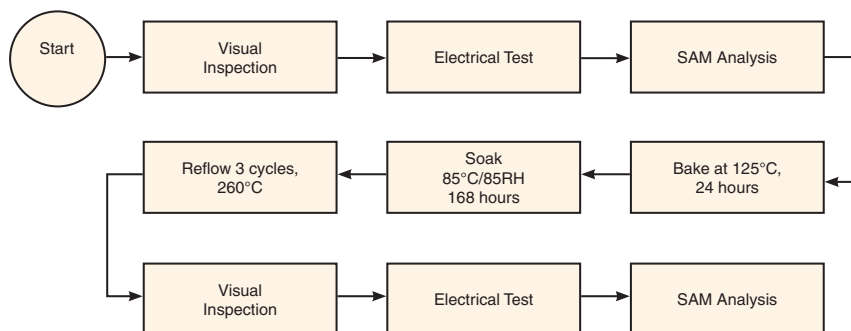

For detailed performance specs & shopping online see web site

P.O. Box 350166, Brooklyn, New York 11235-0003 (718) 934-4500 Fax (718) 332-4661 The Design Engineers Search Engine Provides ACTUAL Data Instantly at minicircuits.com

Notes: 1. Performance and quality attributes and conditions not expressly stated in this specification sheet are intended to be excluded and do not form a part of this specification sheet. 2. Electrical specifications and performance data contained herein are based on Mini-Circuit's applicable established test performance criteria and measurement instructions. 3. The parts covered by this specification sheet are subject to Mini-Circuits standard limited warranty and terms and conditions (collectively, "Standard Terms"); Purchasers of this part are entitled to the rights and benefits contained therein. For a full statement of the Standard Terms and the exclusive rights and remedies thereunder, please visit Mini-Circuits' website at www.minicircuits.com/MCLStore/terms.jsp.