

High Directivity

Monolithic Amplifier Die

MNA-4A-D+

50Ω 0.5 to 4.5 GHz

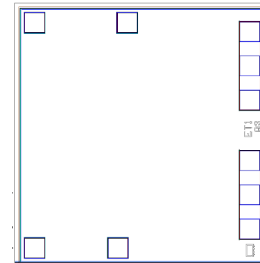

The Big Deal

- Integrated matching, DC Blocks and bias circuits
- Excellent Active Directivity
- Operates over 2.8-5V

Product Overview

MNA-4A-D+ is a wideband PHEMT based MMIC amplifier die with high active Directivity. MNA integrates the entire matching network and majority of the bias circuit inside the die, reducing the need for complicated external circuits. This approach makes the MNA amplifier die extremely straightforward to use. This design operates on a single 2.8 to 5V supply, is well matched for 50Ω.

Key Features

Feature	Advantages
Excellent Active Directivity (Isolation- Gain) 19-35 dB	Ideal for use as a buffer amplifier minimizing interaction of adjacent circuits
Integrates DC blocks and RF choke	Minimizes external components, component count and circuit area.
Single +2.8 to +5V operation	Amplifier can be used at low voltage such as +3V or standard +5V. +5V operation results in higher P1dB and OIP3.
Unpackaged die	Enables the user to integrate the amplifier directly into hybrids.

High Directivity

Monolithic Amplifier Die

MNA-4A-D+

50Ω 0.5 to 4.5 GHz

Product Features

- Choice of supply voltage, +2.8V to +5V
- Internal DC blocking at RF input and output
- High directivity, 19-32 dB typ.
- Output power, up to +19 dBm typ.

Typical Applications

- Buffer amplifier
- Cellular infrastructure
- Communications satellite
- Defense

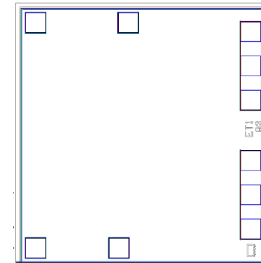

+RoHS Compliant

The +Suffix identifies RoHS Compliance. See our web site for RoHS Compliance methodologies and qualifications

Ordering Information: Refer to Last Page

General Description

MNA-4A-D+ is a wideband PHEMT based MMIC amplifier die with high active Directivity. MNA integrates the entire matching network and majority of the bias circuit inside the die, reducing the need for complicated external circuits. This approach makes the MNA amplifier die extremely straightforward to use. This design operates on a single +2.8 to +5V supply, is well matched for 50Ω.

Simplified Schematic and Pad description

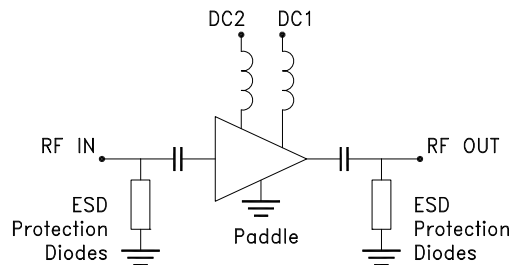

Pad	Description
RF IN	RF input pad.
RF-OUT	RF output pad
DC1 & DC2	DC Supply pad. Connect DC2 to DC1 via 33.2Ω resistor

Electrical Specifications¹ at 25°C

Parameter	Condition (GHz)	Vs=5V			Vs=2.8V	Units
		Min.	Typ.	Max.	Typ.	
Frequency Range		0.5		4.5	0.5-4.5	GHz
Gain	0.5		16.0		14.2	dB
	1.0		17.8		15.4	
	2.0		17.8		14.9	
	2.5		17.0		14.2	
	3.5		13.9		11.6	
	4.5		9.8		8.1	
Input Return Loss	0.5		5.2		5.5	dB
	1.0		14.6		14.5	
	2.0		31.1		26.9	
	2.5		29.8		30.4	
	3.5		15.6		15.4	
	4.5		7.8		8.0	
Output Return Loss	0.5		12.9		12.1	dB
	1.0		25.9		12.7	
	2.0		15.6		11.2	
	2.5		15.0		11.3	
	3.5		17.7		12.6	
	4.5		16.7		11.8	
Output Power at P1dB	0.5		18.7		10.7	dBm
	1.0		18.6		11.8	
	2.0		17.2		12.0	
	2.5		16.8		12.1	
	3.5		15.2		11.9	
	4.5		13.5		10.8	
Output IP3	0.5		30.9		22.8	dBm
	1.0		30.8		23.5	
	2.0		28.5		23.4	
	2.5		27.9		23.2	
	3.5		26.3		22.4	
	4.5		25.0		21.3	
Noise Figure (dB)	0.5		4.9		5.0	dB
	1.0		4.4		4.5	
	2.0		4.5		4.6	
	2.5		4.5		4.6	
	3.5		4.7		4.9	
	4.5		5.5		5.8	
Directivity (Isolation-Gain)	0.5		31.8		35.3	dB
	1.0		26.2		26.2	
	2.0		19.4		20.5	
	2.5		19.0		19.7	
	3.5		20.8		20.7	
	4.5		23.9		23.5	
DC Current			75.1	94.0	70.6	mA
Device Current Variation vs. Temperature ⁽²⁾			35		17	μA/°C
Device Current Variation vs Voltage			0.001 ⁽³⁾		0.003 ⁽⁴⁾	mA/mV
Thermal resistance at 85°C (Junction to Lead)			50		50	°C/W

1. Measured on Mini-Circuits characterization test board. Die packaged in 3x3 mm MCLP package and soldered on test board TB-186+

2. (Current at 85°C - Current at -45°C)/130

3. (Current at 5.25V - Current at 3.9V)/1.35

4. (Current at 3.9V - Current at 2.66V)/1.24

Absolute Maximum Ratings^{1,5}

Parameter	Ratings
Operating Temperature	-40°C to 85°C
DC Voltage	7V at DC1 (DC2 connected to DC1 via 33.2Ω) 1V at RF IN & RF OUT
Power Dissipation	500 mW
Input Power	+13 dBm (continuous operation)
	+24 dBm (5 minutes max)

5. Permanent damage may occur if any of these limits are exceeded. These ratings are not intended for continuous normal operation.

Characterization Circuit

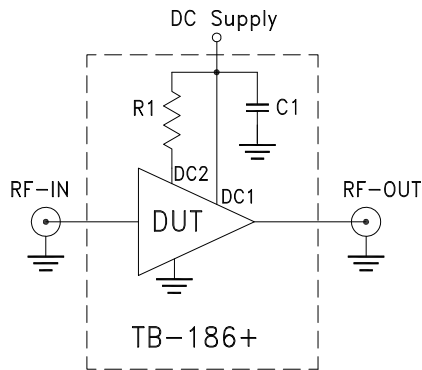

Component	Size	Value	Units
R1	0805	33.2	Ω
C1	0402	1000	ρF

Fig 1. Block Diagram of Test Circuit used for characterization. (Die packaged in 3x3 mm MCLP package and soldered on Mini-Circuits Characterization test board TB-186+) Gain, Return loss, Output power at 1dB compression (P1 dB) , output IP3 (OIP3) and noise figure measured using Agilent’s N5242A PNA-X microwave network analyzer.

Conditions:

1. Gain and Return loss: Pin= -25dBm
2. Output IP3 (OIP3): Two tones, spaced 1 MHz apart, 0 dBm/tone at output.

Recommended Application Circuit

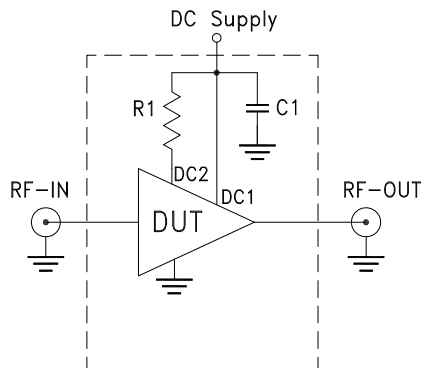

Component	Value	Units
R1	33.2	Ω
C1	1000	ρF

Fig 2. Test Board includes case, connectors, and components soldered to PCB

Die Layout

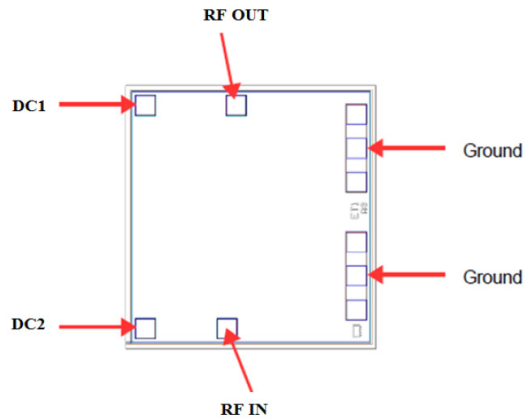

Fig 3. Die Layout

Bonding Pad Position
(Dimensions in μm, Typical)

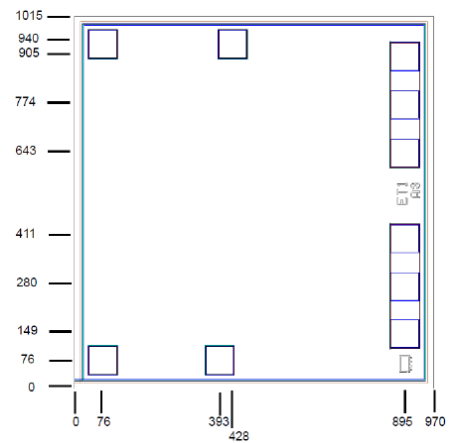

Fig 4. Bonding Pad Positions

Critical Dimensions

Parameter	Values
Die Thickness, μm	100
Die Width, μm	970
Die Length, μm	1015
Bond Pad Size (RF In, RF Out, DC), μm	80 x 80
Bond Pad Size (Ground pad), μm	80 x 340

Assembly and Handling Procedure

1. Storage
Dice should be stored in a dry nitrogen purged desiccators or equivalent.
2. ESD
MMIC PHEMT amplifier dice are susceptible to electrostatic and mechanical damage. Die are supplied in antistatic protected material, which should be opened in clean room conditions at an appropriately grounded anti-static workstation. Devices need careful handling using correctly designed collets, vacuum pickup tips or sharp antistatic tweezers to deter ESD damage to dice.
3. Die Attach
The die mounting surface must be clean and flat. Using conductive silver filled epoxy, recommended epoxies are DieMat DM6030HK-PT/H579 or Ablestik 84-1LMISR4. Apply sufficient epoxy to meet required epoxy bond line thickness, epoxy fillet height and epoxy coverage around total die periphery. Parts shall be cured in a nitrogen filled atmosphere per manufacturer's cure condition. It is recommended to use antistatic die pick up tools only.
4. Wire Bonding
Bond pad openings in the surface passivation above the bond pads are provided to allow wire bonding to the dice gold bond pads. Thermosonic bonding is used with minimized ultrasonic content. Bond force, time, ultrasonic power and temperature are all critical parameters. Suggested wire is pure gold, 1 mil diameter. Bonds must be made from the bond pads on the die to the package or substrate. All bond wires should be kept as short as low as reasonable to minimize performance degradation due to undesirable series inductance.

Assembly Diagram

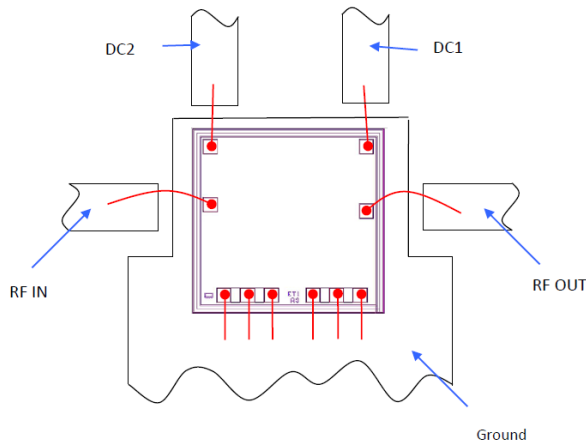

Recommended Wire Length, Typical

Wire	Wire Length (mm)	Wire Loop Height (mm)
RF In, RF Out	1.0	0.15
DC	0.5	0.15
Ground	0.5	0.15

Additional Detailed Technical Information <i>additional information is available on our dash board.</i>	
Performance Data	Data Table
	Swept Graphs
	S-Parameter (S2P Files) Data Set with and without port extension(.zip file)
Case Style	Die
Die Ordering and packaging information	Quantity, Package Model No.
	Small, Gel - Pak: 5,10,50,100 KGD* MNA-4A-DG+ Medium†, Partial wafer: KGD*<5K MNA-4A-DP+ Large†, Full Wafer MNA-4A-DF+
	†Available upon request contact sales representative
	Refer to AN-60-067
Environmental Ratings	ENV-80

*Known Good Dice (“KGD”) means that the dice in question have been subjected to Mini-Circuits DC test performance criteria and measurement instructions and that the parametric data of such dice fall within a predefined range. While DC testing is not definitive, it does help to provide a higher degree of confidence that dice are capable of meeting typical RF electrical parameters specified by Mini-Circuits.

ESD Rating**

Human Body Model (HBM): Class 1A (250 to <500V) in accordance with ANSI/ESD STM 5.1 - 2001

Machine Model (MM): Class M1 (Pass 50V) in accordance with ANSI/ESD STM5.2-1999

** Tested in industry standard 3X3 mm 8 lead MCLP

Additional Notes

- A. Performance and quality attributes and conditions not expressly stated in this specification document are intended to be excluded and do not form a part of this specification document.
- B. Electrical specifications and performance data contained in this specification document are based on Mini-Circuit's applicable established test performance criteria and measurement instructions.
- C. The parts covered by this specification document are subject to Mini-Circuits standard limited warranty and terms and conditions (collectively, “Standard Terms”); Purchasers of this part are entitled to the rights and benefits contained therein. For a full statement of the Standard Terms and the exclusive rights and remedies thereunder, please visit Mini-Circuits’ website at www.minicircuits.com/MCLStore/terms.jsp
- D. Mini-Circuits does not warrant the accuracy or completeness of the information, text, graphics and other items contained within this document and same are provided as an accommodation and on an “As is” basis, with all faults.
- E. Purchasers of this part are solely responsible for proper storing, handling, assembly and processing of Known Good Dice (including, without limitation, proper ESD preventative measures, die preparation, die attach, wire bonding and related assembly and test activities), and Mini-Circuits assumes no responsibility therefor or for environmental effects on Known Good Dice.
- F. Mini-Circuits and the Mini-Circuits logo are registered trademarks of Scientific Components Corporation d/b/a Mini-Circuits. All other third-party trademarks are the property of their respective owners. A reference to any third-party trademark does not constitute or imply any endorsement, affiliation, sponsorship, or recommendation by any such third-party of Mini-Circuits or its products.

