

Ultra High Dynamic Range

Monolithic Amplifier

LHY-1H+

50Ω 0.05 to 6 GHz

The Big Deal

- Ultra High IP3
- Broadband High Dynamic Range without external Matching Components
- Small size 2 x 2 mm



CASE STYLE: MC1630-1

Product Overview

LHY-1H+ (RoHS compliant) is an advanced wideband amplifier fabricated using E-PHEMT technology and offers extremely high dynamic range over a broad frequency range and with low noise figure. In addition, the LHY-1H+, unlike competitive models, is well matched (input and output) over a broad frequency range without the need for external matching components. Lead finish is tin-silver over nickel. It is enclosed in a 2x2 mm MCLP package for low parasitic interface.

Key Features

Feature	Advantages
Broad Band: 0.05 to 6.0 GHz	Broadband covering primary wireless communications bands: Cellular, PCS, LTE, WiMAX
Extremely High IP3 versus DC power Consumption 41 dBm typical at 2 GHz	The LHY-1H+ matches industry leading IP3 performance relative to device size and power consumption. The combination of the design and E-PHEMT Structure provides enhanced linearity over a broad frequency range as evidence in the IP3 being typically 17 dB above the P 1dB point. This feature makes this amplifier ideal for use in: <ul style="list-style-type: none">• Driver amplifiers for complex waveform up converter paths• Drivers in linearized transmit systems• Secondary amplifiers in ultra High Dynamic range receivers
Low Noise Figure: 2.7 dB typ. up to 4 GHz 3.1 dB typ. up to 6 GHz	A unique feature of the LHY-1H+ which separates this design from all competitors is the low noise figure performance in combination with the high dynamic range.
Small size 2 x 2 mm	Saves PCB area



Ultra High Dynamic Range

Monolithic Amplifier

0.05-6 GHz

Product Features

- High IP3, 41 dBm typ. at 2 GHz, 5V
- Gain, 14.0 dB typ. at 2 GHz, 5V
- High Pout, P1dB 22.5 dBm typ. at 2 GHz, 5V
- Low noise figure, 2.1 dB @2 GHz, 5V
- Usable to 4.0V
- No external matching components required



LHY-1H+

CASE STYLE: MC1630-1

Typical Applications

- Base station infrastructure
- Portable Wireless
- CATV & DBS
- MMDS & Wireless LAN
- LTE

+RoHS Compliant

The +Suffix identifies RoHS Compliance. See our web site for RoHS Compliance methodologies and qualifications

General Description

LHY-1H+ (RoHS compliant) is an advanced wideband amplifier fabricated using E-PHEMT technology and offers extremely high dynamic range over a broad frequency range and with low noise figure. In addition, the LHY-1H+ has well matched input and output over a broad frequency range without the need for external matching components. Lead finish is tin-silver over nickel. It has repeatable performance from lot to lot and is enclosed in a 2 x 2 mm MCLP package for low parasitic interface.

simplified schematic and pad description

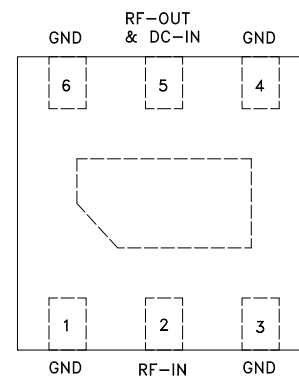
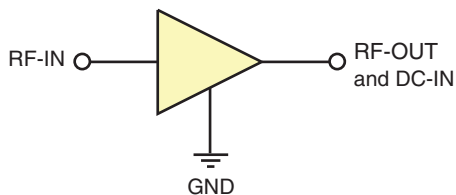

Function	Pad Number	Description
RF-IN	2	RF input pin.
RF-OUT and DC-IN	5	RF output and bias pin.
GND	1,3,4,6 paddle	Connections to ground.

Electrical Specifications¹ at 25°C, unless noted

Parameter	Condition (GHz)	Vd=5.0V			Vd=4.5V	Vd=4.0V	Units
		Min.	Typ.	Max.	Typ.	Typ.	
Frequency Range		0.05		6	0.05-6	0.05-6	GHz
Gain	0.05	16.0	17.7	19.6	17.5	17.3	dB
	0.8	14.3	15.8	17.5	15.7	15.4	
	2.0		14.0		13.8	13.6	
	3.0		12.4		12.2	11.9	
	4.0	9.9	10.9	12.0	10.7	10.4	
Input Return Loss	0.05		11.1		11.0	10.6	dB
	0.8	12.5	15.5		15.3	14.9	
	2.0		10.9		10.8	10.6	
	3.0		9.2		9.1	8.9	
	4.0		7.8		7.7	7.6	
Output Return Loss	0.05		14.1		14.0	13.8	dB
	0.8	16.0	21.0		20.6	20.0	
	2.0		18.8		18.0	16.8	
	3.0		17.3		16.6	15.4	
	4.0		16.2		15.4	14.3	
Reverse Isolation	0.05		19.3		19.1	18.9	dB
	0.8		19.3		19.1	18.9	
	2.0		19.3		19.1	18.9	
	3.0		19.3		19.1	18.9	
	4.0		19.3		19.1	18.9	
Output Power @ 1 dB compression	0.05	20.0	22.7		21.4	19.9	dBm
	0.8	20.0	22.6		21.4	19.9	
	2.0	20.0	22.5		21.3	19.8	
	3.0		22.8		21.5	19.9	
	4.0		22.7		21.5	20.0	
Output IP3	0.05		40.1		37.9	34.6	dBm
	0.8	37.0	40.0		39.7	35.1	
	2.0		41.0		36.3	33.0	
	3.0		41.6		36.2	32.6	
	4.0		40.8		35.7	32.2	
Noise Figure	0.05		1.6		1.5	1.4	dB
	0.8		1.8		1.7	1.7	
	2.0		2.1		2.0	2.0	
	3.0		2.3		2.3	2.2	
	4.0		2.6		2.4	2.4	
Device Operating Voltage	0.05		3.1		3.1	2.8	V
	0.8		3.1		3.1	2.8	
	2.0		3.1		3.1	2.8	
	3.0		3.1		3.1	2.8	
	4.0		3.1		3.1	2.8	
Device Operating Current		4.8	5.0	5.2	4.5	4.0	mA
Device Current Variation vs. Temperature ²			113		136	152	µA/°C
Device Current Variation vs Voltage			0.059		0.057	0.056	mA/mV
Thermal Resistance, junction-to-ground lead			55		55	55	°C/W

1. Measured on Mini-Circuits Characterization test board TB-621+. See Characterization Test Circuit (Fig. 1)
 2. (Current at 85°C — Current at -45°C)/130

Absolute Maximum Ratings³

Parameter	Ratings
Operating Temperature (ground lead)	-40°C to 85°C
Storage Temperature	-65°C to 150°C
Operating Current at 5V	210 mA
Power Dissipation	1 W
Input Power (CW)	24 dBm
DC Voltage on Pad 5	6 V

3. Permanent damage may occur if any of these limits are exceeded.
 Electrical maximum ratings are not intended for continuous normal operation.

Characterization Test Circuit

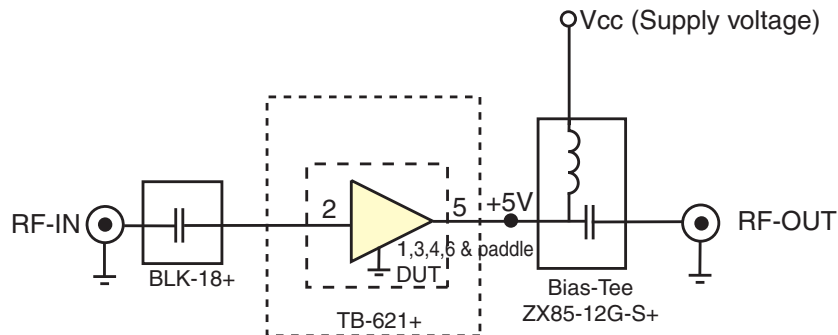
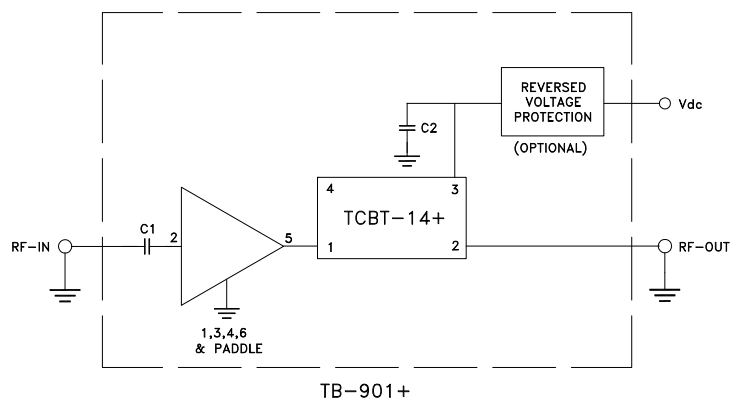

Fig 1. Block Diagram of Test Circuit used for characterization. (DUT soldered on Mini-Circuits Characterization test board TB-621+) Gain, Return loss, Output power at 1dB compression (P1 dB) , output IP3 (OIP3) and noise figure measured using Agilent’s N5242A PNA-X microwave network analyzer.

Conditions:

1. Gain and Return loss: Pin= -25dBm
2. Output IP3 (OIP3): Two tones, spaced 1 MHz apart, 5 dBm/tone at output.

Recommended Application Circuit



COMPONENT	SIZE	VALUE	P/N	MANUFACTURER
C1	0402	1nF	-	VARIOUS
C2	0805	1nF	-	VARIOUS
BIAS-TEE	-	-	TCBT-14+	MINI-CIRCUITS

Fig 2. Test Board includes case, connectors, and components soldered to PCB.

Product Marking

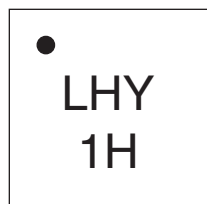

Marking may contain other features or characters for internal lot control

Additional Detailed Technical Information	
<i>additional information is available on our dash board. To access this information click here</i>	
Performance Data	Data Table
	Swept Graphs
	S-Parameter (S2P Files) Data Set (.zip file)
Case Style	MC1630-1 (2x2 mm MCLP) <i>Plastic package, exposed paddle lead finish: tin-silver over nickel</i>
Tape & Reel Standard quantities available on reel	F66 <i>7" reels with 20, 50, 100, 200, 500 or 1K devices</i>
Suggested Layout for PCB Design	PL-493
Evaluation Board	TB-901+
Environmental Ratings	ENV08T1

ESD Rating

Human Body Model (HBM): Class 1B (500 to <1000V) in accordance with ANSI/ESD STM 5.1 - 2001

Machine Model (MM): Class M1 (>25V) in accordance with ANSI/ESD STM5.2-1999

MSL Rating

Moisture Sensitivity: MSL1 in accordance with IPC/JEDEC J-STD-020D

MSL Test Flow Chart

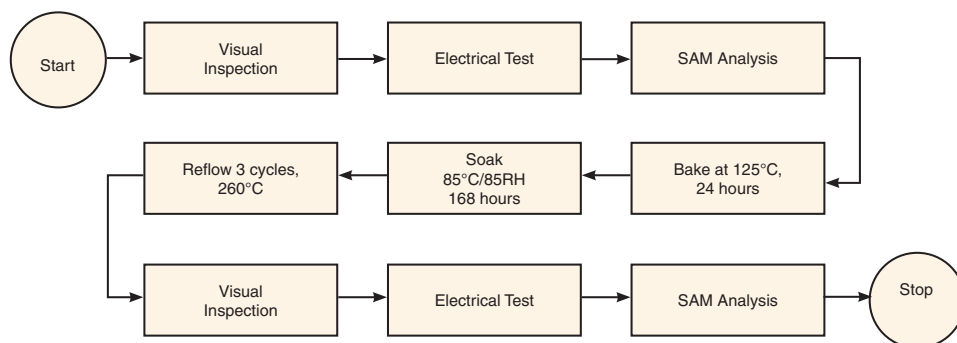

Additional Notes

- A. Performance and quality attributes and conditions not expressly stated in this specification document are intended to be excluded and do not form a part of this specification document.
- B. Electrical specifications and performance data contained in this specification document are based on Mini-Circuit's applicable established test performance criteria and measurement instructions.
- C. The parts covered by this specification document are subject to Mini-Circuits standard limited warranty and terms and conditions (collectively, "Standard Terms"); Purchasers of this part are entitled to the rights and benefits contained therein. For a full statement of the Standard Terms and the exclusive rights and remedies thereunder, please visit Mini-Circuits' website at www.minicircuits.com/MCLStore/terms.jsp