

Ceramic Low Pass Filter

50Ω DC⁽¹⁾ to 6000 MHz

LFCN-6000



CASE STYLE: FV1206

Available Tape and Reel at no extra cost

Reel Size	Devices/Reel
7"	20, 50, 100, 200, 500, 1000, 3000

Maximum Ratings

Operating Temperature	-55°C to 100°C
Storage Temperature	-55°C to 100°C
RF Power Input*	9W max. at 25°C

* Passband rating, derate linearly to 3W at 100°C ambient. Permanent damage may occur if any of these limits are exceeded.

Pin Connections

RF IN	1
RF OUT	3
GROUND	2,4

Outline Drawing

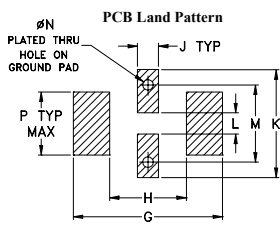
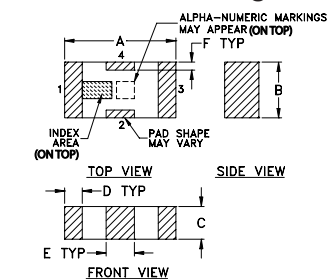

Suggested Layout, Tolerance to be within ±0.02

Outline Dimensions (inch/mm)

A	B	C	D	E	F	G
.126	.063	.037	.020	.032	.009	.169
3.20	1.60	0.94	0.51	0.81	0.23	4.29
H	J	K	L	M	N	P
.087	.024	.122	.024	.087	.012	.071
2.21	0.61	3.10	0.61	2.21	0.30	1.80
						wt
						grams
						.020

Demo Board MCL P/N: TB-270 Suggested PCB Layout (PL-137)

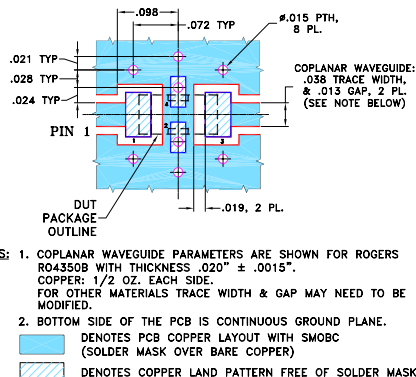

Features

- excellent power handling, 9W
- small size
- 7 sections
- temperature stable
- LTCC construction
- protected by U.S. Patent 6,943,646

Applications

- harmonic rejection
- VHF/UHF transmitters/receivers
- lab use

Electrical Specifications^(1,2) at 25°C

Parameter	F#	Frequency (MHz)	Min.	Typ.	Max.	Unit	
Pass Band	Insertion Loss	DC-F1	DC-6000	—	—	1.2	dB
	Freq. Cut-Off	F2	6800	—	3.0	—	dB
	VSWR	DC-F1	DC-6000	—	1.3	—	:1
Stop Band	Rejection Loss	F3	8500	20	—	—	dB
		F4-F5	8700-10500	—	30	—	dB
		F6	18000	—	20	—	dB
	VSWR	F3-F6	8500-18000	—	20	—	:1

(1) In Application where DC voltage is present at either input or output ports, coupling capacitors are required. Alternatively, if DC pass IN-OUT is required, Mini-Circuits' "D" suffix version of this model will support DC IN-OUT, and provide >100 MOhm isolation to ground.

(2) Measured on Mini-Circuits Characterization Test Board TB-270.

Typical Frequency Response

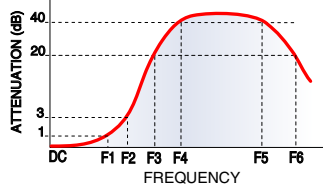

Electrical Schematic

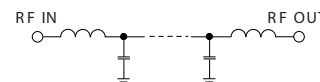

Typical Performance Data at 25°C

Frequency (MHz)	Insertion Loss (dB)	VSWR (:1)
50.00	0.10	1.01
100.00	0.02	1.01
1000.00	0.10	1.03
3000.00	0.19	1.07
5000.00	0.57	1.37
6000.00	0.75	1.24
6800.00	2.80	3.31
8000.00	21.90	15.96
8720.00	44.10	17.22
10000.00	58.33	19.76
12000.00	30.77	15.26
13700.00	27.55	1.37
15000.00	27.44	8.72
18000.00	21.31	10.02
20000.00	26.23	7.44

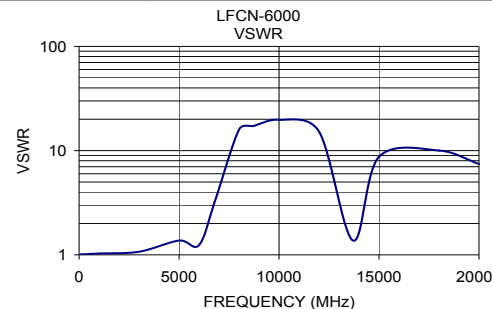
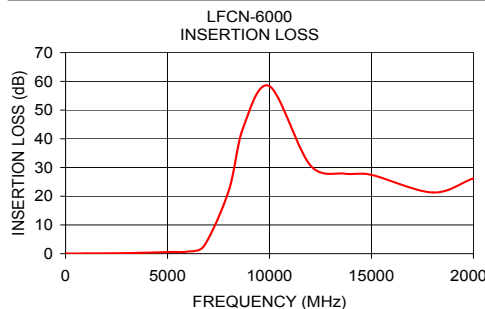

Notes

- Performance and quality attributes and conditions not expressly stated in this specification document are intended to be excluded and do not form a part of this specification document.
- Electrical specifications and performance data contained in this specification document are based on Mini-Circuit's applicable established test performance criteria and measurement instructions.
- The parts covered by this specification document are subject to Mini-Circuits standard limited warranty and terms and conditions (collectively, "Standard Terms"); Purchasers of this part are entitled to the rights and benefits contained therein. For a full statement of the Standard Terms and the exclusive rights and remedies thereunder, please visit Mini-Circuits' website at www.minicircuits.com/MCLStore/terms.jsp

