

# Ceramic Low Pass Filter

## LFCN-180

50Ω DC<sup>(1)</sup> to 180 MHz



CASE STYLE: FV1206

### Maximum Ratings

Operating Temperature	-55°C to 100°C
Storage Temperature	-55°C to 100°C
RF Power Input*	8W max. at 25°C

\* Passband rating, derate linearly to 3W at 100°C ambient. Permanent damage may occur if any of these limits are exceeded.

### Pin Connections

RF IN	1
RF OUT	3
GROUND	2,4

### Outline Drawing

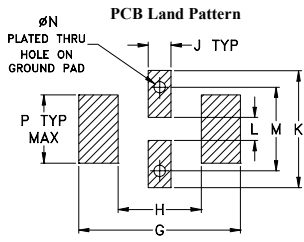
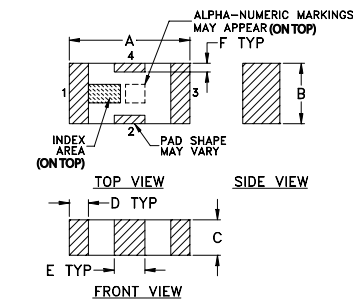

Suggested Layout, Tolerance to be within ±.002

### Outline Dimensions (inch)

A	B	C	D	E	F	G
.126	.063	.037	.020	.032	.009	.169
3.20	1.60	0.94	0.51	0.81	0.23	4.29

H	J	K	L	M	N	P	wt
.087	.024	.122	.024	.087	.012	.071	grams
2.21	0.61	3.10	0.61	2.21	0.30	1.80	.020

### Demo Board MCL P/N: TB-270 Suggested PCB Layout (PL-137)

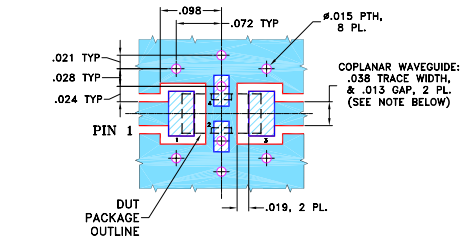

NOTES: 1. COPLANAR WAVEGUIDE PARAMETERS ARE SHOWN FOR ROGERS RO4350B WITH THICKNESS .020" ± .0015". COPPER: 1/2 OZ. EACH SIDE. FOR OTHER MATERIALS TRACE WIDTH & GAP MAY NEED TO BE MODIFIED.

2. BOTTOM SIDE OF THE PCB IS CONTINUOUS GROUND PLANE.
- DENOTES PCB COPPER LAYOUT WITH SMOBC (SOLDER MASK OVER BARE COPPER)
  - DENOTES COPPER LAND PATTERN FREE OF SOLDER MASK

#### Notes

- A. Performance and quality attributes and conditions not expressly stated in this specification document are intended to be excluded and do not form a part of this specification document.
- B. Electrical specifications and performance data contained in this specification document are based on Mini-Circuit's applicable established test performance criteria and measurement instructions.
- C. The parts covered by this specification document are subject to Mini-Circuits standard limited warranty and terms and conditions (collectively, "Standard Terms"); Purchasers of this part are entitled to the rights and benefits contained therein. For a full statement of the Standard Terms and the exclusive rights and remedies thereunder, please visit Mini-Circuits' website at [www.minicircuits.com/MCLStore/terms.jsp](http://www.minicircuits.com/MCLStore/terms.jsp)

### Features

- excellent power handling, 8W
- small size
- 7 sections
- temperature stable
- hermetically sealed
- LTCC construction
- protected by U.S. Patent 6,943,646

### Applications

- harmonic rejection
- VHF/UHF transmitters/receivers
- lab use

### Electrical Specifications<sup>(1,2)</sup> at 25°C

Parameter	F#	Frequency (MHz)	Min.	Typ.	Max.	Unit	
Pass Band	Insertion Loss	DC-F1	DC-180	—	—	1.0	dB
	Freq. Cut-Off	F2	270	—	3.0	—	dB
	VSWR	DC-F1	DC-180	—	1.2	—	:1
Stop Band	Rejection Loss	F3-F4	370-525	20	—	—	dB
		F4-F5	525-2350	—	40	—	dB
		F5-F6	2350-6400	—	20	—	dB
	VSWR	F3-F6	370-6400	—	17	—	:1

(1) In Application where DC voltage is present at either input or output ports, coupling capacitors are required.

(2) Measured on Mini-Circuits Characterization Test Board TB-270.

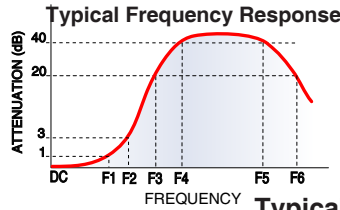

### Electrical Schematic

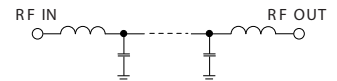

### Typical Performance Data at 25°C

Frequency (MHz)	Insertion Loss (dB)	VSWR (:1)
40	0.29	1.08
100	0.47	1.08
180	0.85	1.14
235	1.55	1.39
270	3.15	1.82
300	7.47	2.89
325	14.93	4.47
350	25.55	5.79
370	35.04	6.37
525	40.41	11.85
950	64.01	54.29
1700	47.93	69.49
2350	42.01	64.35
4500	25.94	28.49
6400	20.10	27.16
8500	33.14	8.12
12000	20.84	3.93

