

Ceramic Low Pass Filter

50Ω DC⁽¹⁾ to 1575 MHz

LFCN-1575+



CASE STYLE: FV1206

Maximum Ratings

Operating Temperature	-55°C to 100°C
Storage Temperature	-55°C to 100°C
RF Power Input*	10W max. at 25°C

* Passband rating, derate linearly to 3.5W at 100°C ambient. Permanent damage may occur if any of these limits are exceeded.

Pin Connections

RF IN	1
RF OUT	3
GROUND	2,4

Outline Drawing

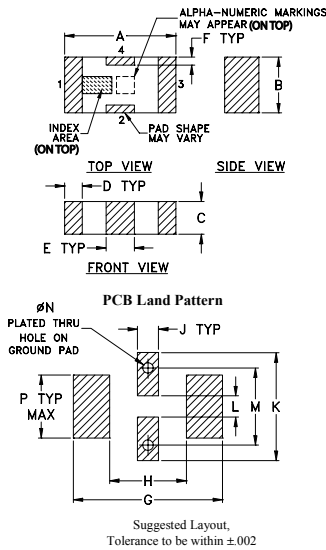

Outline Dimensions (inch/mm)

A	B	C	D	E	F	G	
.126	.063	.037	.020	.032	.009	.169	
3.20	1.60	0.94	0.51	0.81	0.23	4.29	
H	J	K	L	M	N	P	wt
.087	.024	.122	.024	.087	.012	.071	grams
2.21	0.61	3.10	0.61	2.21	0.30	1.80	.020

Demo Board MCL P/N: TB-270 Suggested PCB Layout (PL-137)

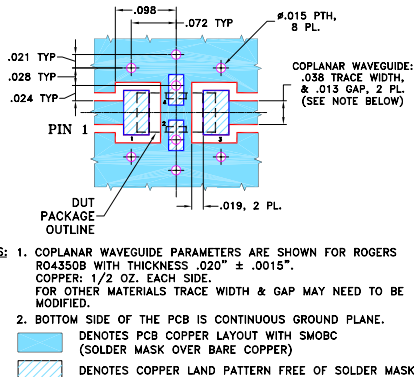

Notes

- Performance and quality attributes and conditions not expressly stated in this specification document are intended to be excluded and do not form a part of this specification document.
- Electrical specifications and performance data contained in this specification document are based on Mini-Circuit's applicable established test performance criteria and measurement instructions.
- The parts covered by this specification document are subject to Mini-Circuits standard limited warranty and terms and conditions (collectively, "Standard Terms"); Purchasers of this part are entitled to the rights and benefits contained therein. For a full statement of the Standard Terms and the exclusive rights and remedies thereunder, please visit Mini-Circuits' website at www.minicircuits.com/MCLStore/terms.jsp

Features

- excellent power handling, 10W
- small size
- 7 sections
- temperature stable
- LTCC construction
- protected by U.S Patent 6,943,646

Applications

- harmonic rejection
- VHF/UHF transmitters/receivers
- lab use

Electrical Specifications^(1,2) at 25°C

Parameter	F#	Frequency (MHz)	Min.	Typ.	Max.	Unit	
Pass Band	Insertion Loss	DC-F1	DC-1575	—	—	1.0	dB
	Freq. Cut-Off	F2	1875	—	3.0	—	dB
	VSWR	DC-F1	DC-1575	—	1.2	—	:1
Stop Band	Rejection Loss	F3	2175	20	—	—	dB
		F4-F5	2225-6800	—	30	—	dB
		F6	7100	—	20	—	dB
	VSWR	F3-F6	2175-7100	—	20	—	:1

(1) In Application where DC voltage is present at either input or output ports, coupling capacitors are required. Alternatively, if DC pass IN-OUT is required, Mini-Circuits' "D" suffix version of this model will support DC IN-OUT, and provide >100 MOhm isolation to ground.

(2) Measured on Mini-Circuits Characterization Test Board TB-270.

Typical Frequency Response

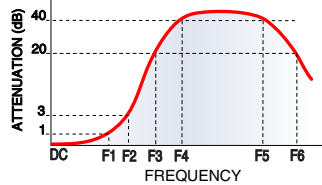

Electrical Schematic



Typical Performance Data at 25°C

Frequency (MHz)	Insertion Loss (dB)	VSWR (:1)
100.00	0.08	1.03
1000.00	0.36	1.11
1575.00	0.76	1.21
1875.00	2.32	2.03
2000.00	7.66	5.56
2200.00	35.08	16.11
2275.00	32.67	18.90
2500.00	41.82	26.33
2700.00	37.22	32.18
4000.00	41.10	51.10
5000.00	43.27	48.26
6000.00	37.34	34.07
6800.00	35.05	27.16
7200.00	20.70	18.90
9000.00	16.86	17.57

