

Frequency Synthesizer

KSN-1127A-119+

50Ω 1109.1 to 1123.9 MHz

The Big Deal

- Fractional N synthesizer
- Low phase noise and spurious
- Robust design and construction
- Small size 0.80" x 0.58" x 0.15"



CASE STYLE: DK1042

Product Overview

The KSN-1127A-119+ is a Frequency Synthesizer, designed to operate from 1109.1 to 1123.9 MHz for GSM application. The KSN-1127A-119+ is packaged in a metal case (size of 0.80" x 0.58" x 0.15") to shield against unwanted signals and noise.

Key Features

Feature	Advantages
Low phase noise and spurious: <ul style="list-style-type: none">• Phase Noise: -106 dBc/Hz typ. @ 10 kHz offset• Step Size Spurious: -84 dBc typ.• Comparison Spurious: -83 dBc typ.• Reference Spurious: -80 dBc typ.	Low phase noise and spurious improve system EVM (Error Vector Magnitude).
Robust design and construction	To enhance the robustness of KSN-1127A-119+, each internal component is secured to the substrate with chip bonder, thereby eliminating the risk of tombstoning during subsequent solder reflow operations by the customer.
Small size, 0.80" x 0.58" x 0.15"	The small size enables the KSN-1127A-119+ to be used in compact designs.



IF/RF MICROWAVE COMPONENTS • ISO 9001 ISO 14001 AS9100 CERTIFIED RoHS compliant
P.O. Box 350166, Brooklyn, New York 11235-0003 (718) 934-4500 Fax (718) 332-4661



The Design Engineers Search Engine finds the model you need, Instantly • For detailed performance specs & shopping online see



Notes: 1. Performance and quality attributes and conditions not expressly stated in this specification sheet are intended to be excluded and do not form a part of this specification sheet. 2. Electrical specifications and performance data contained herein are based on Mini-Circuit's applicable established test performance criteria and measurement instructions. 3. The parts covered by this specification sheet are subject to Mini-Circuits standard limited warranty and terms and conditions (collectively, "Standard Terms"); Purchasers of this part are entitled to the rights and benefits contained therein. For a full statement of the Standard Terms and the exclusive rights and remedies thereunder, please visit Mini-Circuits' website at www.minicircuits.com/MCLStore/terms.jsp.

Frequency Synthesizer

KSN-1127A-119+

50Ω 1109.1 to 1123.9 MHz

Features

- Fractional N synthesizer
- Integrated VCO + PLL
- Low phase noise and spurious
- Robust design and construction
- Low operating voltage (VCC VCO=+5.5V, VCC PLL=+3.3V)
- Small size 0.80" x 0.58" x 0.15"

Applications

- GSM

General Description

The KSN-1127A-119+ is a Frequency Synthesizer, designed to operate from 1109.1 to 1123.9 MHz for GSM application. The KSN-1127A-119+ is packaged in a metal case (size of 0.80" x 0.58" x 0.15) to shield against unwanted signals and noise. To enhance the robustness of KSN-1127A-119+, each internal component is secured to the substrate with chip bonder, thereby eliminating the risk of tombstoning during subsequent solder reflow operations by the customer.



CASE STYLE: DK1042
PRICE: \$29.95 ea. QTY (1-9)

+ RoHS compliant in accordance with EU Directive (2002/95/EC)

The +Suffix has been added in order to identify RoHS Compliance. See our web site for RoHS Compliance methodologies and qualifications.

Simplified Schematic

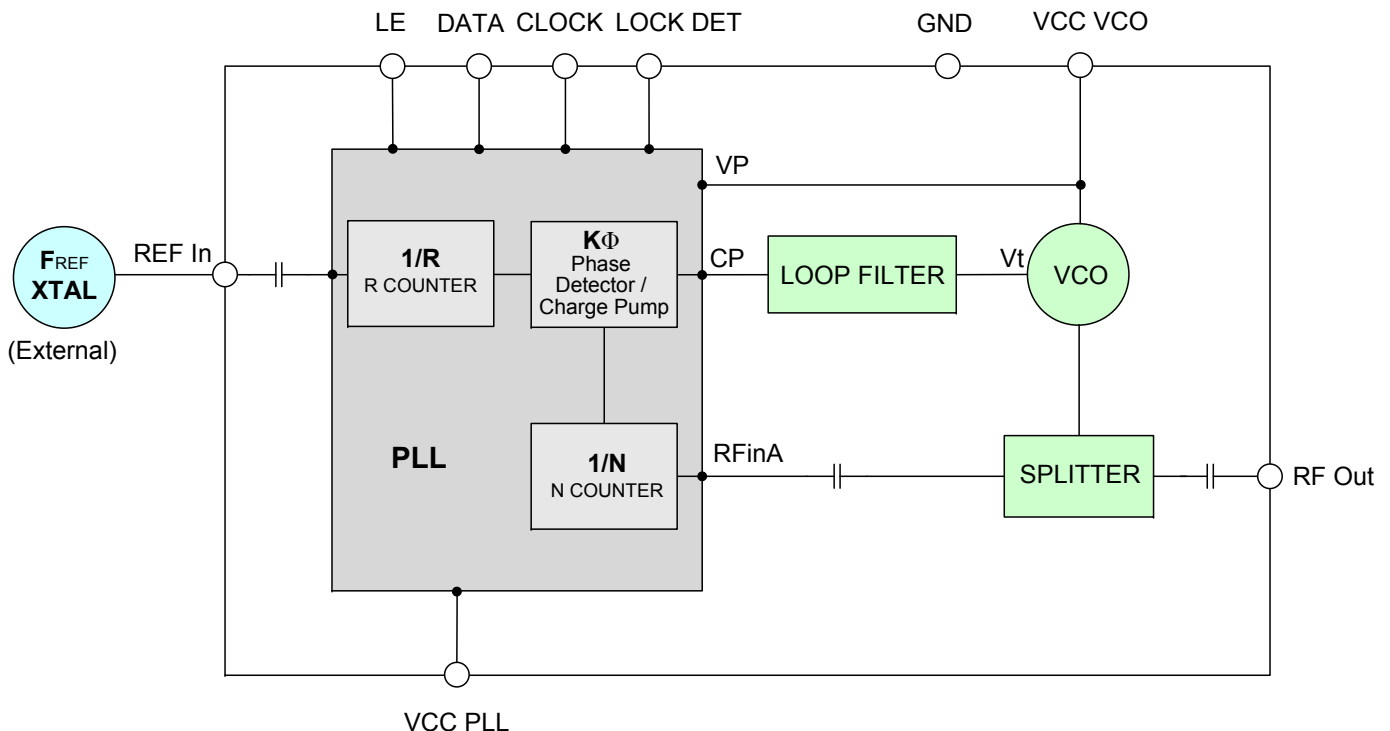

IF/RF MICROWAVE COMPONENTS • ISO 9001 ISO 14001 AS9100 CERTIFIED RoHS compliant
P.O. Box 350166, Brooklyn, New York 11235-0003 (718) 934-4500 Fax (718) 332-4661



The Design Engineers Search Engine finds the model you need, Instantly • For detailed performance specs & shopping online see



Notes: 1. Performance and quality attributes and conditions not expressly stated in this specification sheet are intended to be excluded and do not form a part of this specification sheet. 2. Electrical specifications and performance data contained herein are based on Mini-Circuit's applicable established test performance criteria and measurement instructions. 3. The parts covered by this specification sheet are subject to Mini-Circuits standard limited warranty and terms and conditions (collectively, "Standard Terms"); Purchasers of this part are entitled to the rights and benefits contained therein. For a full statement of the Standard Terms and the exclusive rights and remedies thereunder, please visit Mini-Circuits' website at www.minicircuits.com/MCLStore/terms.jsp.

Electrical Specifications (over operating temperature -40°C to +85°C)

Parameters	Test Conditions	Min.	Typ.	Max.	Units
Frequency Range	-	1109.1	-	1123.9	MHz
Step Size	-	-	199.48	-	kHz
Comparison Frequency	-	-	30.72	-	MHz
Settling Time	Within ± 1 kHz	-	150	-	mSec
Output Power	-	+2.0	+5.5	+8.0	dBm
SSB Phase Noise	@ 100 Hz offset	-	-80	-	dBc/Hz
	@ 1 kHz offset	-	-87	-80	
	@ 10 kHz offset	-	-106	-101	
	@ 100 kHz offset	-	-136	-129	
	@ 1 MHz offset	-	-157	-150	
Step Size Spurious Suppression	Step Size 199.48 kHz	-	-84	-70	dBc
Reference Spurious Suppression	Ref. Freq. 61.44 MHz	-	-80	-64	
Comparison Spurious Suppression	Comp. Freq. 30.72 MHz	-	-83	-67	
Non - Harmonic Spurious Suppression	-	-	-90	-	
Harmonic Suppression	-	-	-42	-25	
VCO Supply Voltage	5.50	5.25	5.50	5.75	V
PLL Supply Voltage	3.30	3.15	3.30	3.45	
VCO Supply Current	-	-	54	61	mA
PLL Supply Current	-	-	17	25	
Reference Input (External)	Frequency	61.44 (square wave)	-	61.44	MHz
	Amplitude	1.0	0.8	1.0	V _{P-P}
	Input impedance	-	-	100	KΩ
	Phase Noise @ 1 kHz offset	-	-	-125	dBc/Hz
RF Output port Impedance	-	-	50	-	Ω
Input Logic Level	Input high voltage	-	2.80	-	V
	Input low voltage	-	-	0.60	V
Digital Lock Detect	Locked	-	2.75	3.84	V
	Unlocked	-	-	0.40	V
Frequency Synthesizer PLL	-	ADF4153			
PLL Programming	-	3-wire serial 3.3V CMOS			
Register Map @ 1123.9MHz	R0_Register	-	(MSB) 00001001000000101101000 (LSB)		
	R1_Register	-	(MSB) 000100001000001001101001 (LSB)		
	R2_Register	-	(MSB) 000000000000000001100010 (LSB)		
	R3_Register	-	(MSB) 00000000000000000000011 (LSB)		

Absolute Maximum Ratings

Parameters	Ratings
VCO Supply Voltage	5.8V
PLL Supply Voltage	4.0V
VCO Supply Voltage to PLL Supply Voltage	-0.3V to +5.8V
Reference Frequency Voltage	-0.3Vmin, VCC PLL +0.3Vmax
Data, Clock, LE Levels	-0.3Vmin, VCC PLL +0.3Vmax
Operating Temperature	-40°C to +85°C
Storage Temperature	-55°C to +100°C

Permanent damage may occur if any of these limits are exceeded



IF/RF MICROWAVE COMPONENTS • ISO 9001 ISO 14001 AS9100 CERTIFIED RoHS compliant
 P.O. Box 350166, Brooklyn, New York 11235-0003 (718) 934-4500 Fax (718) 332-4661

The Design Engineers Search Engine finds the model you need, Instantly • For detailed performance specs & shopping online see minicircuits.com

Notes: 1. Performance and quality attributes and conditions not expressly stated in this specification sheet are intended to be excluded and do not form a part of this specification sheet. 2. Electrical specifications and performance data contained herein are based on Mini-Circuit's applicable established test performance criteria and measurement instructions. 3. The parts covered by this specification sheet are subject to Mini-Circuits standard limited warranty and terms and conditions (collectively, "Standard Terms"); Purchasers of this part are entitled to the rights and benefits contained therein. For a full statement of the Standard Terms and the exclusive rights and remedies thereunder, please visit Mini-Circuits' website at www.minicircuits.com/MCLStore/terms.jsp.

Typical Performance Data

FREQUENCY (MHz)	POWER OUTPUT (dBm)			VCO CURRENT (mA)			PLL CURENT (mA)		
	-45°C	+25°C	+85°C	-45°C	+25°C	+85°C	-45°C	+25°C	+85°C
	1109.10	5.55	5.61	5.62	52.95	53.92	55.95	15.17	17.06
1110.95	5.45	5.59	5.60	51.37	53.88	55.91	15.38	17.29	19.33
1112.80	5.44	5.58	5.58	51.32	53.83	55.88	15.50	17.42	19.46
1114.65	5.42	5.56	5.56	51.27	53.79	55.84	15.61	17.54	19.59
1116.50	5.43	5.54	5.54	51.72	53.74	55.81	15.67	17.60	19.65
1118.35	5.45	5.53	5.52	52.24	53.70	55.78	15.71	17.65	19.70
1120.20	5.46	5.51	5.50	52.67	53.65	55.75	15.74	17.68	19.73
1122.05	5.44	5.48	5.47	52.64	53.61	55.72	15.70	17.64	19.69
1123.90	5.42	5.46	5.45	52.60	53.57	55.68	15.66	17.60	19.64

FREQUENCY (MHz)	HARMONICS (dBc)					
	F2			F3		
	-45°C	+25°C	+85°C	-45°C	+25°C	+85°C
1109.10	-41.23	-42.71	-43.60	-39.37	-43.24	-43.52
1110.95	-40.93	-42.51	-43.33	-39.09	-42.87	-43.36
1112.80	-40.48	-42.25	-42.95	-38.72	-42.30	-43.19
1114.65	-40.04	-41.99	-42.57	-38.36	-41.72	-43.02
1116.50	-39.53	-41.52	-42.21	-38.21	-41.42	-42.95
1118.35	-39.01	-41.03	-41.86	-38.10	-41.16	-42.88
1120.20	-38.51	-40.55	-41.53	-38.03	-40.95	-42.86
1122.05	-38.12	-40.16	-41.38	-38.21	-40.92	-43.05
1123.90	-37.73	-39.77	-41.23	-38.39	-40.90	-43.24



IF/RF MICROWAVE COMPONENTS • ISO 9001 ISO 14001 AS9100 CERTIFIED RoHS compliant
 P.O. Box 350166, Brooklyn, New York 11235-0003 (718) 934-4500 Fax (718) 332-4661



The Design Engineers Search Engine finds the model you need, Instantly • For detailed performance specs & shopping online see



Notes: 1. Performance and quality attributes and conditions not expressly stated in this specification sheet are intended to be excluded and do not form a part of this specification sheet. 2. Electrical specifications and performance data contained herein are based on Mini-Circuit's applicable established test performance criteria and measurement instructions. 3. The parts covered by this specification sheet are subject to Mini-Circuits standard limited warranty and terms and conditions (collectively, "Standard Terms"); Purchasers of this part are entitled to the rights and benefits contained therein. For a full statement of the Standard Terms and the exclusive rights and remedies thereunder, please visit Mini-Circuits' website at www.minicircuits.com/MCLStore/terms.jsp.

FREQUENCY (MHz)	PHASE NOISE (dBc/Hz) @ OFFSETS				
	+25°C				
	100Hz	1kHz	10kHz	100kHz	1MHz
1109.10	-81.66	-88.06	-106.30	-137.51	-157.65
1110.95	-83.31	-87.84	-106.40	-137.49	-158.48
1112.80	-81.69	-87.14	-106.22	-137.43	-158.40
1114.65	-80.08	-86.43	-106.03	-137.36	-158.33
1116.50	-80.24	-86.10	-105.90	-137.04	-157.80
1118.35	-80.68	-85.83	-105.77	-136.69	-157.21
1120.20	-80.96	-85.66	-105.66	-136.31	-156.61
1122.05	-80.44	-86.00	-105.68	-135.76	-156.03
1123.90	-79.91	-86.35	-105.69	-135.21	-155.45

FREQUENCY (MHz)	PHASE NOISE (dBc/Hz) @ OFFSETS				
	-45°C				
	100Hz	1kHz	10kHz	100kHz	1MHz
1109.10	-81.41	-88.47	-107.67	-136.49	-157.93
1110.95	-82.64	-88.15	-106.44	-134.15	-155.49
1112.80	-81.71	-86.95	-106.05	-134.29	-155.39
1114.65	-80.78	-85.74	-105.65	-134.43	-155.29
1116.50	-81.13	-86.49	-106.26	-134.85	-155.80
1118.35	-81.68	-87.53	-107.03	-135.32	-156.41
1120.20	-82.10	-88.17	-107.65	-135.78	-156.85
1122.05	-81.93	-86.83	-107.58	-136.25	-156.48
1123.90	-81.75	-85.49	-107.52	-136.72	-156.11

FREQUENCY (MHz)	PHASE NOISE (dBc/Hz) @ OFFSETS				
	+85°C				
	100Hz	1kHz	10kHz	100kHz	1MHz
1109.10	-77.12	-86.39	-106.40	-133.70	-156.17
1110.95	-79.75	-87.09	-106.36	-135.07	-155.63
1112.80	-80.91	-87.01	-106.33	-134.80	-155.65
1114.65	-82.07	-86.94	-106.30	-134.53	-155.67
1116.50	-81.92	-86.85	-106.09	-134.35	-155.45
1118.35	-81.58	-86.76	-105.86	-134.19	-155.21
1120.20	-81.29	-86.66	-105.64	-133.88	-154.97
1122.05	-81.32	-86.56	-105.49	-132.84	-154.82
1123.90	-81.34	-86.45	-105.35	-131.79	-154.66



IF/RF MICROWAVE COMPONENTS • ISO 9001 ISO 14001 AS9100 CERTIFIED RoHS compliant
 P.O. Box 350166, Brooklyn, New York 11235-0003 (718) 934-4500 Fax (718) 332-4661



The Design Engineers Search Engine finds the model you need, Instantly • For detailed performance specs & shopping online see



Notes: 1. Performance and quality attributes and conditions not expressly stated in this specification sheet are intended to be excluded and do not form a part of this specification sheet. 2. Electrical specifications and performance data contained herein are based on Mini-Circuit's applicable established test performance criteria and measurement instructions. 3. The parts covered by this specification sheet are subject to Mini-Circuits standard limited warranty and terms and conditions (collectively, "Standard Terms"); Purchasers of this part are entitled to the rights and benefits contained therein. For a full statement of the Standard Terms and the exclusive rights and remedies thereunder, please visit Mini-Circuits' website at www.minicircuits.com/MCLStore/terms.jsp.

COMPARISON SPURIOUS ORDER	COMPARISON SPURIOUS @Fcarrier 1109.1MHz+(n*Fcomparison) (dBc) note 1			COMPARISON SPURIOUS @Fcarrier 1116.5MHz+(n*Fcomparison) (dBc) note 1			COMPARISON SPURIOUS @Fcarrier 1123.9MHz+(n*Fcomparison) (dBc) note 1			
	n	-45°C	+25°C	+85°C	-45°C	+25°C	+85°C	-45°C	+25°C	+85°C
	-5	-85.44	-89.97	-93.82	-83.23	-85.94	-90.74	-82.26	-83.55	-86.93
-4	-80.26	-81.14	-83.37	-81.70	-81.76	-82.91	-83.53	-82.95	-82.98	
-3	-91.45	-92.29	-95.47	-93.38	-90.79	-93.62	-97.60	-90.13	-92.48	
-2	-103.76	-98.22	-103.27	-98.46	-102.89	-100.39	-95.82	-112.29	-102.73	
-1	-99.37	-104.43	-101.97	-94.25	-105.88	-102.98	-91.87	-101.07	-100.86	
0 note 2	-	-	-	-	-	-	-	-	-	
+1	-88.83	-99.18	-100.90	-90.09	-94.22	-100.03	-94.10	-91.21	-99.31	
+2	-96.18	-113.22	-103.46	-99.63	-111.83	-99.10	-101.36	-103.88	-96.86	
+3	-91.39	-89.63	-89.60	-90.40	-89.24	-89.89	-90.12	-88.63	-90.88	
+4	-91.49	-91.29	-89.41	-93.83	-91.76	-88.77	-93.24	-91.36	-88.66	
+5	-88.85	-92.20	-90.42	-87.20	-91.89	-90.66	-86.54	-91.43	-91.10	

Note 1: Comparison frequency 30.72 MHz
 Note 2: All spurs are referenced to carrier signal (n=0).

REFERENCE SPURIOUS ORDER	REFERENCE SPURIOUS @Fcarrier 1109.1MHz+(n*Freference) (dBc) note 3			REFERENCE SPURIOUS @Fcarrier 1116.5MHz+(n*Freference) (dBc) note 3			REFERENCE SPURIOUS @Fcarrier 1123.9MHz+(n*Freference) (dBc) note 3			
	n	-45°C	+25°C	+85°C	-45°C	+25°C	+85°C	-45°C	+25°C	+85°C
	-5	-92.90	-78.90	-75.29	-91.87	-79.13	-75.06	-90.13	-79.29	-74.81
-4	-82.01	-83.49	-88.76	-81.98	-83.10	-88.06	-82.31	-83.17	-86.99	
-3	-91.53	-83.07	-84.43	-91.17	-83.22	-83.85	-90.32	-84.23	-83.52	
-2	-80.33	-81.19	-83.38	-81.69	-81.78	-82.86	-83.47	-82.96	-82.95	
-1	-104.24	-98.17	-102.85	-98.51	-102.45	-100.26	-96.12	-111.94	-102.84	
0 note 4	-	-	-	-	-	-	-	-	-	
+1	-96.25	-110.96	-103.44	-99.84	-112.19	-99.61	-101.87	-104.54	-97.10	
+2	-91.48	-91.26	-89.55	-93.88	-91.77	-88.77	-93.33	-91.34	-88.66	
+3	-89.45	-86.08	-85.13	-88.76	-84.86	-84.72	-88.14	-84.53	-84.28	
+4	-84.64	-91.36	-91.12	-84.35	-90.65	-91.81	-84.72	-89.93	-92.48	
+5	-98.02	-84.94	-81.89	-98.11	-84.59	-81.83	-97.86	-84.81	-81.57	

Note 3: Reference frequency 61.44 MHz
 Note 4: All spurs are referenced to carrier signal (n=0).



IF/RF MICROWAVE COMPONENTS • ISO 9001 ISO 14001 AS9100 CERTIFIED RoHS compliant
 P.O. Box 350166, Brooklyn, New York 11235-0003 (718) 934-4500 Fax (718) 332-4661



The Design Engineers Search Engine finds the model you need, Instantly • For detailed performance specs & shopping online see



Notes: 1. Performance and quality attributes and conditions not expressly stated in this specification sheet are intended to be excluded and do not form a part of this specification sheet. 2. Electrical specifications and performance data contained herein are based on Mini-Circuit's applicable established test performance criteria and measurement instructions. 3. The parts covered by this specification sheet are subject to Mini-Circuits standard limited warranty and terms and conditions (collectively, "Standard Terms"); Purchasers of this part are entitled to the rights and benefits contained therein. For a full statement of the Standard Terms and the exclusive rights and remedies thereunder, please visit Mini-Circuits' website at www.minicircuits.com/MCLStore/terms.jsp.

STEP SIZE SPURIOUS ORDER n	STEP SIZE SPURIOUS @Fcarrier 1108.9122MHz+(n*Fstep size) (dBc) note 5			STEP SIZE SPURIOUS @Fcarrier 1115.9920MHz+(n*Fstep size) (dBc) note 5			STEP SIZE SPURIOUS @Fcarrier 1123.8730MHz+(n*Fstep size) (dBc) note 5		
	-45°C	+25°C	+85°C	-45°C	+25°C	+85°C	-45°C	+25°C	+85°C
-5.0	-116.50	-120.23	-118.44	-113.66	-118.00	-117.96	-114.72	-119.55	-116.86
-4.0	-116.03	-118.60	-117.79	-111.78	-117.09	-115.56	-112.03	-114.60	-114.80
-3.0	-110.52	-107.78	-113.86	-110.92	-108.71	-109.68	-111.89	-114.28	-114.28
-2.0	-106.75	-110.11	-104.47	-83.91	-104.35	-102.02	-109.34	-105.98	-109.31
-1.0	-95.06	-95.17	-93.66	-88.61	-85.46	-88.41	-92.22	-96.62	-95.43
0 ^{note 6}	-	-	-	-	-	-	-	-	-
+1.0	-91.77	-96.61	-97.52	-104.30	-102.60	-105.11	-94.14	-94.34	-97.49
+2.0	-104.08	-105.53	-108.36	-112.03	-113.47	-110.64	-108.27	-104.30	-108.50
+3.0	-114.61	-113.04	-114.27	-112.04	-116.48	-113.81	-112.03	-112.32	-115.22
+4.0	-115.63	-114.81	-114.57	-117.68	-118.15	-117.15	-117.92	-113.85	-115.97
+5.0	-116.33	-116.51	-117.93	-116.31	-113.51	-114.51	-115.37	-116.55	-119.13

Note 5: Step size 199.48 kHz

Note 6: All spurs are referenced to carrier signal (n=0).



IF/RF MICROWAVE COMPONENTS • ISO 9001 ISO 14001 AS9100 CERTIFIED RoHS compliant
 P.O. Box 350166, Brooklyn, New York 11235-0003 (718) 934-4500 Fax (718) 332-4661



The Design Engineers Search Engine finds the model you need, Instantly • For detailed performance specs & shopping online see



Notes: 1. Performance and quality attributes and conditions not expressly stated in this specification sheet are intended to be excluded and do not form a part of this specification sheet. 2. Electrical specifications and performance data contained herein are based on Mini-Circuit's applicable established test performance criteria and measurement instructions. 3. The parts covered by this specification sheet are subject to Mini-Circuits standard limited warranty and terms and conditions (collectively, "Standard Terms"); Purchasers of this part are entitled to the rights and benefits contained therein. For a full statement of the Standard Terms and the exclusive rights and remedies thereunder, please visit Mini-Circuits' website at www.minicircuits.com/MCLStore/terms.jsp.

Typical Performance Curves

OUTPUT POWER Vs FREQUENCY

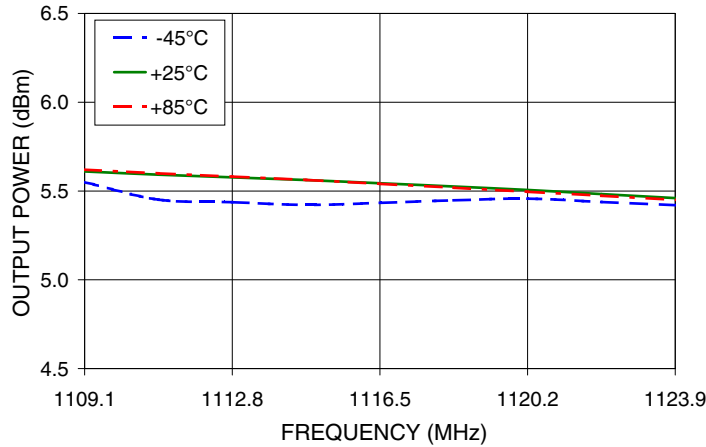

2nd HARMONIC Vs FREQUENCY

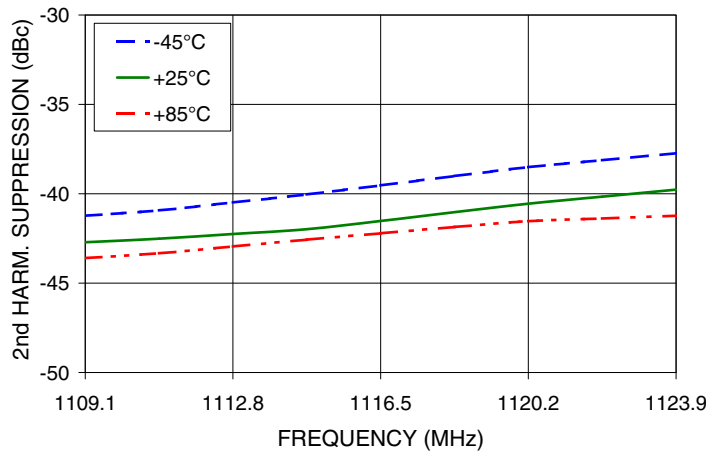

3rd HARMONIC Vs FREQUENCY

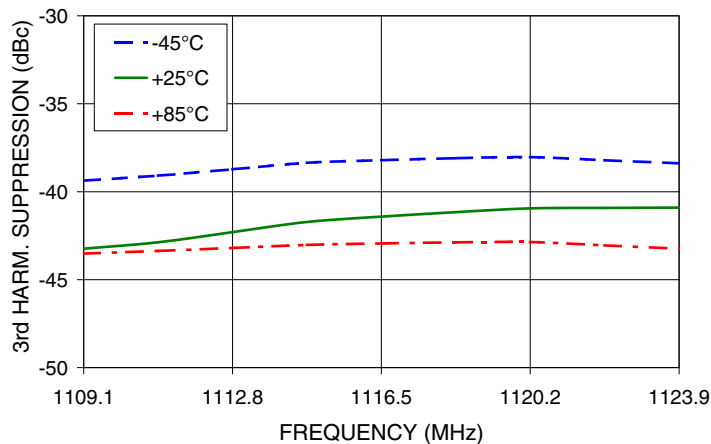

IF/RF MICROWAVE COMPONENTS • ISO 9001 ISO 14001 AS9100 CERTIFIED RoHS compliant
 P.O. Box 350166, Brooklyn, New York 11235-0003 (718) 934-4500 Fax (718) 332-4661



The Design Engineers Search Engine finds the model you need, Instantly • For detailed performance specs & shopping online see



Notes: 1. Performance and quality attributes and conditions not expressly stated in this specification sheet are intended to be excluded and do not form a part of this specification sheet. 2. Electrical specifications and performance data contained herein are based on Mini-Circuit's applicable established test performance criteria and measurement instructions. 3. The parts covered by this specification sheet are subject to Mini-Circuits standard limited warranty and terms and conditions (collectively, "Standard Terms"); Purchasers of this part are entitled to the rights and benefits contained therein. For a full statement of the Standard Terms and the exclusive rights and remedies thereunder, please visit Mini-Circuits' website at www.minicircuits.com/MCLStore/terms.jsp.

PHASE NOISE @100Hz offset

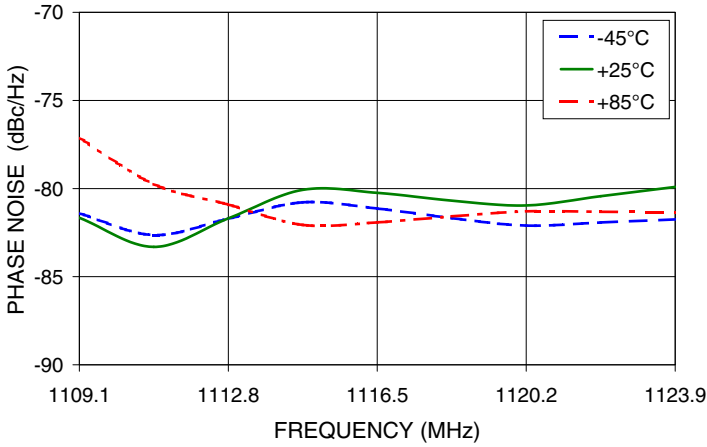

PHASE NOISE @1kHz offset

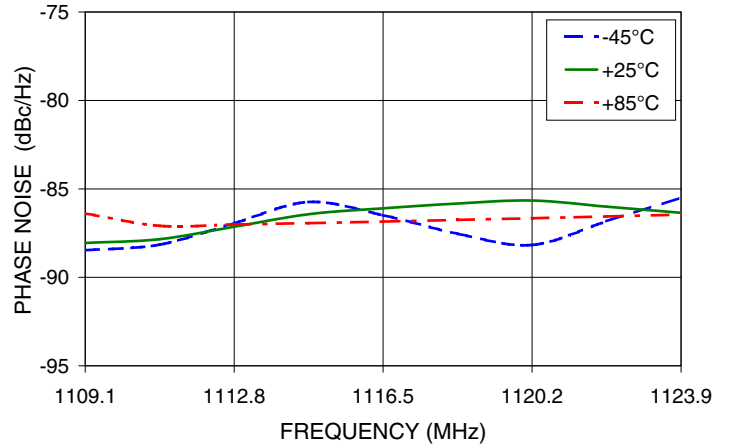

PHASE NOISE @10 kHz offset

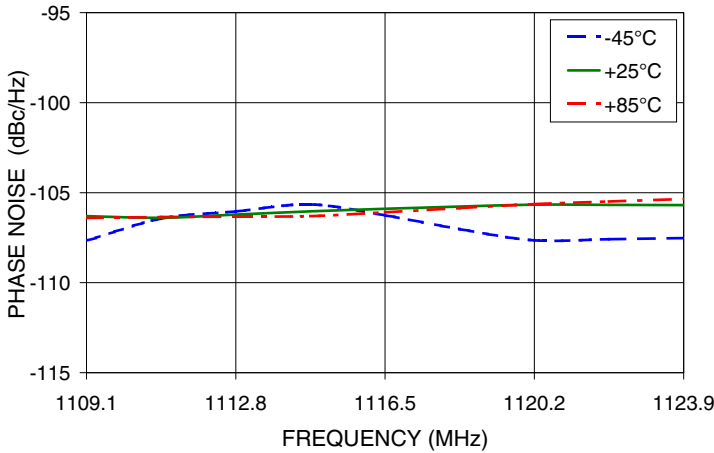

PHASE NOISE @100 kHz offset

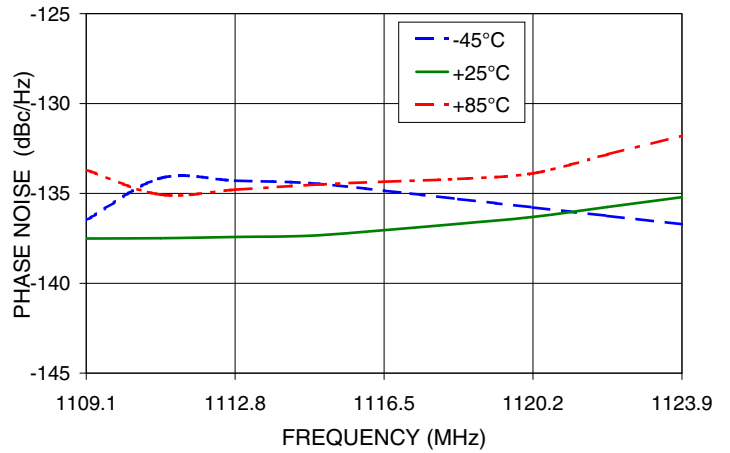

PHASE NOISE @1MHz offset

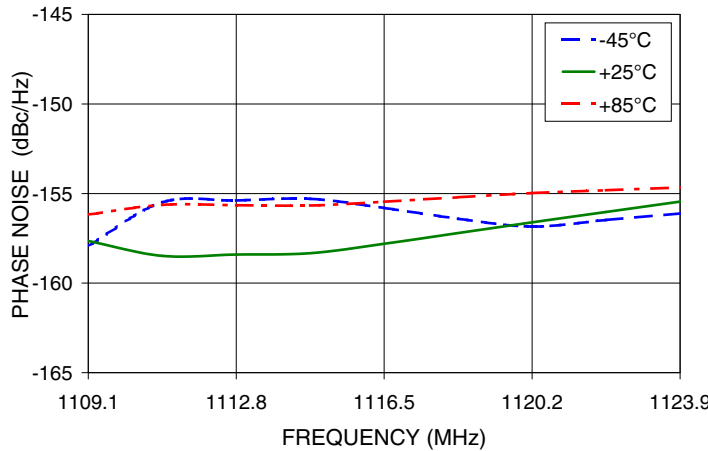

IF/RF MICROWAVE COMPONENTS • ISO 9001 ISO 14001 AS9100 CERTIFIED RoHS compliant
 P.O. Box 350166, Brooklyn, New York 11235-0003 (718) 934-4500 Fax (718) 332-4661



The Design Engineers Search Engine finds the model you need, Instantly • For detailed performance specs & shopping online see



Notes: 1. Performance and quality attributes and conditions not expressly stated in this specification sheet are intended to be excluded and do not form a part of this specification sheet. 2. Electrical specifications and performance data contained herein are based on Mini-Circuit's applicable established test performance criteria and measurement instructions. 3. The parts covered by this specification sheet are subject to Mini-Circuits standard limited warranty and terms and conditions (collectively, "Standard Terms"); Purchasers of this part are entitled to the rights and benefits contained therein. For a full statement of the Standard Terms and the exclusive rights and remedies thereunder, please visit Mini-Circuits' website at www.minicircuits.com/MCLStore/terms.jsp.

COMPARISON SPURIOUS
Vs FREQ. OFFSET @ Fcar = 1109.1MHz

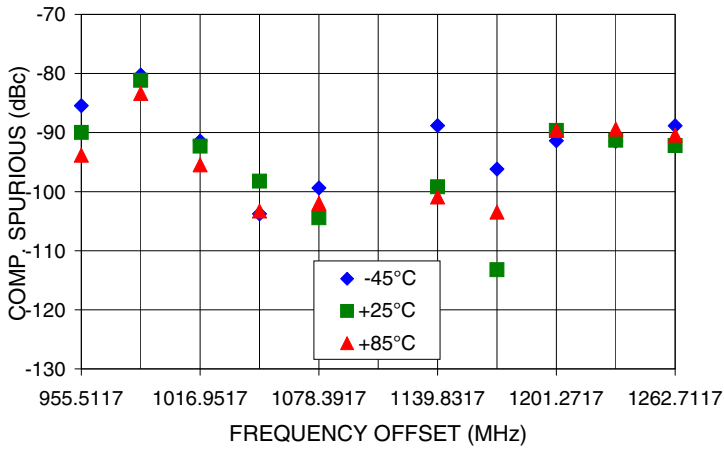

REFERENCE SPURIOUS
Vs FREQ. OFFSET @ Fcar = 1109.1MHz

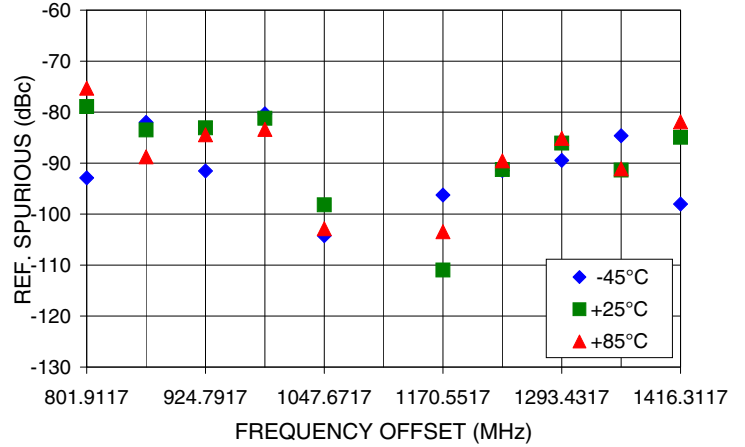

COMPARISON SPURIOUS
Vs FREQ. OFFSET @ Fcar = 1116.5MHz

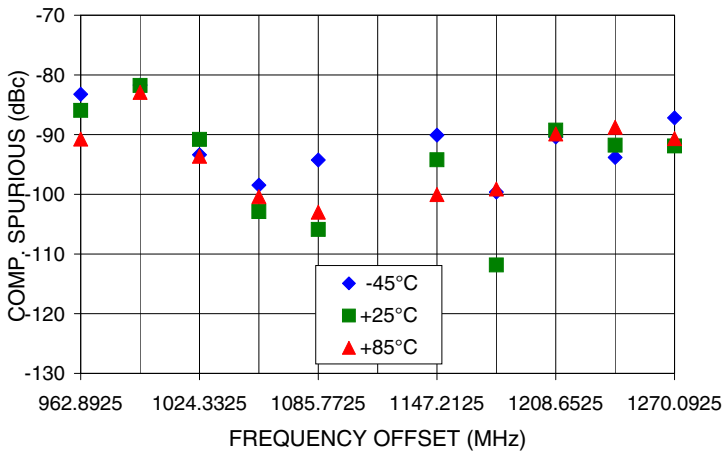

REFERENCE SPURIOUS
Vs FREQ. OFFSET @ Fcar = 1116.5MHz

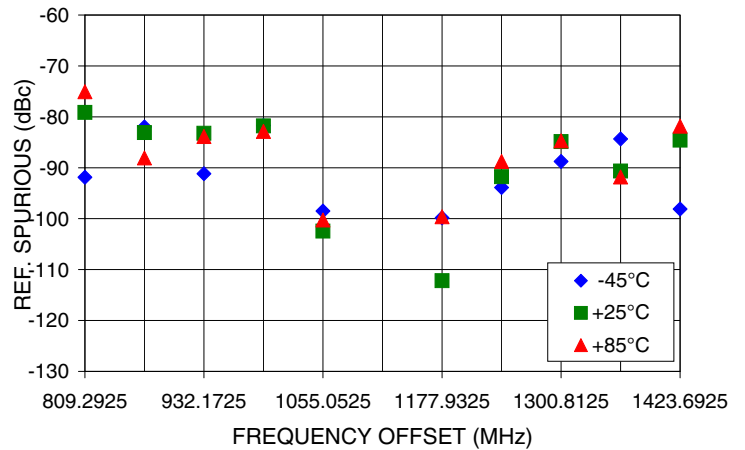

COMPARISON SPURIOUS
Vs FREQ. OFFSET @ Fcar = 1123.9MHz

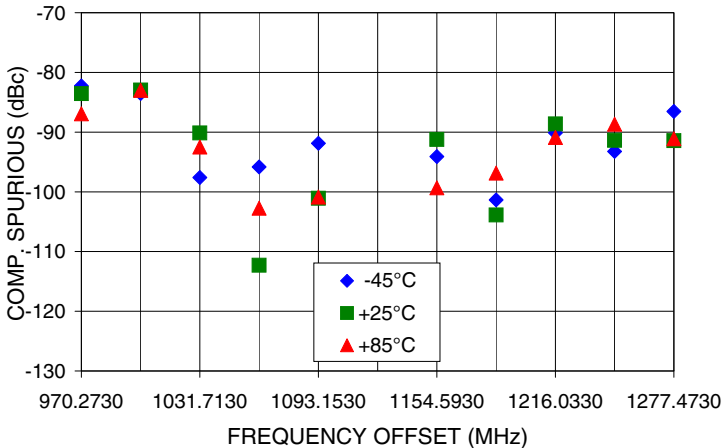

REFERENCE SPURIOUS
Vs FREQ. OFFSET @ Fcar = 1123.9MHz

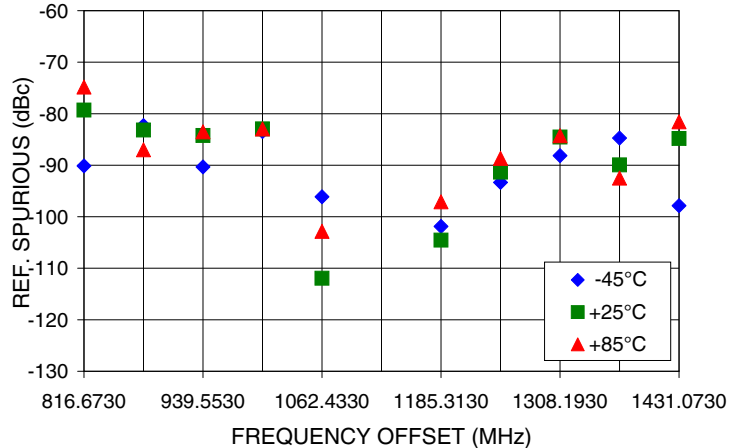

IF/RF MICROWAVE COMPONENTS • ISO 9001 ISO 14001 AS9100 CERTIFIED RoHS compliant
P.O. Box 350166, Brooklyn, New York 11235-0003 (718) 934-4500 Fax (718) 332-4661



The Design Engineers Search Engine finds the model you need, Instantly • For detailed performance specs & shopping online see



Notes: 1. Performance and quality attributes and conditions not expressly stated in this specification sheet are intended to be excluded and do not form a part of this specification sheet. 2. Electrical specifications and performance data contained herein are based on Mini-Circuit's applicable established test performance criteria and measurement instructions. 3. The parts covered by this specification sheet are subject to Mini-Circuits standard limited warranty and terms and conditions (collectively, "Standard Terms"); Purchasers of this part are entitled to the rights and benefits contained therein. For a full statement of the Standard Terms and the exclusive rights and remedies thereunder, please visit Mini-Circuits' website at www.minicircuits.com/MCLStore/terms.jsp.

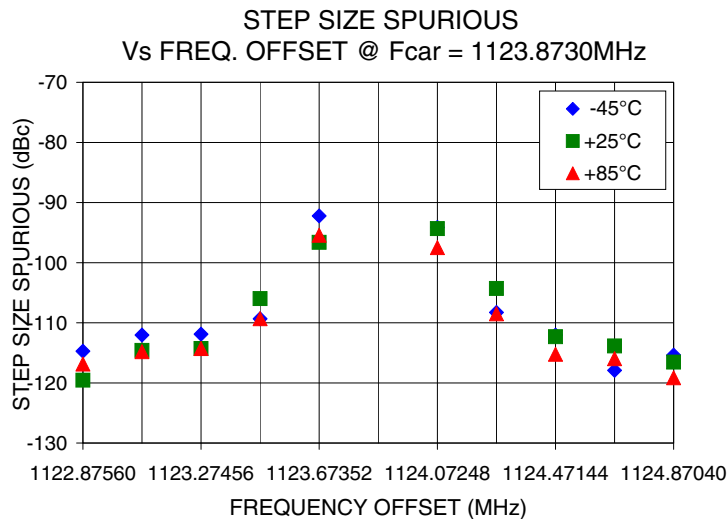
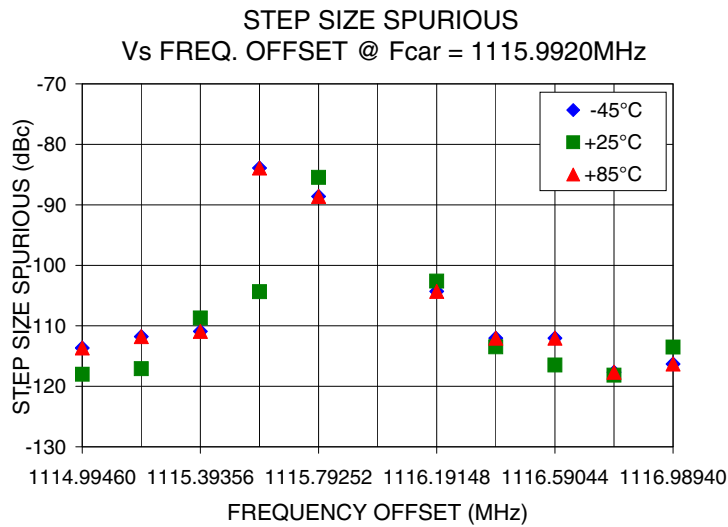
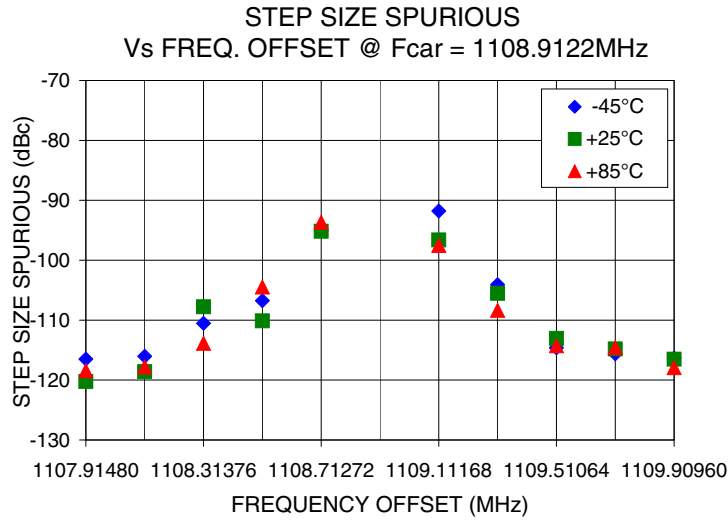

IF/RF MICROWAVE COMPONENTS • ISO 9001 ISO 14001 AS9100 CERTIFIED RoHS compliant
P.O. Box 350166, Brooklyn, New York 11235-0003 (718) 934-4500 Fax (718) 332-4661



The Design Engineers Search Engine finds the model you need, Instantly • For detailed performance specs & shopping online see



Notes: 1. Performance and quality attributes and conditions not expressly stated in this specification sheet are intended to be excluded and do not form a part of this specification sheet. 2. Electrical specifications and performance data contained herein are based on Mini-Circuit's applicable established test performance criteria and measurement instructions. 3. The parts covered by this specification sheet are subject to Mini-Circuits standard limited warranty and terms and conditions (collectively, "Standard Terms"); Purchasers of this part are entitled to the rights and benefits contained therein. For a full statement of the Standard Terms and the exclusive rights and remedies thereunder, please visit Mini-Circuits' website at www.minicircuits.com/MCLStore/terms.jsp.

Pin Configuration

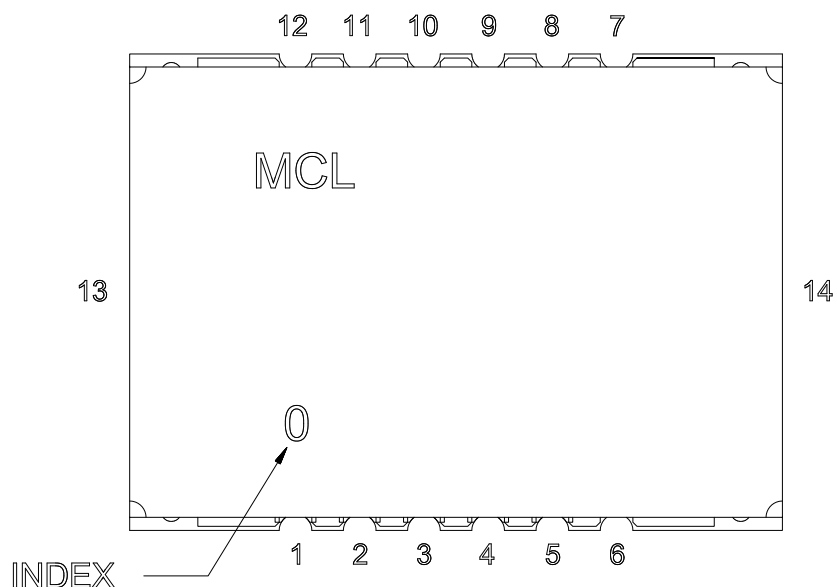

Pin Connection

Pin Number	Function
1	VCC PLL
2	GND
3	REF IN
4	GND
5	VCC VCO
6	GND
7	RF OUT
8	GND
9	LOCK DET
10	CLOCK
11	DATA
12	LE
13	GND
14	GND

Recommended Application Circuit

Note: REF IN and RF OUT ports are internally AC coupled.

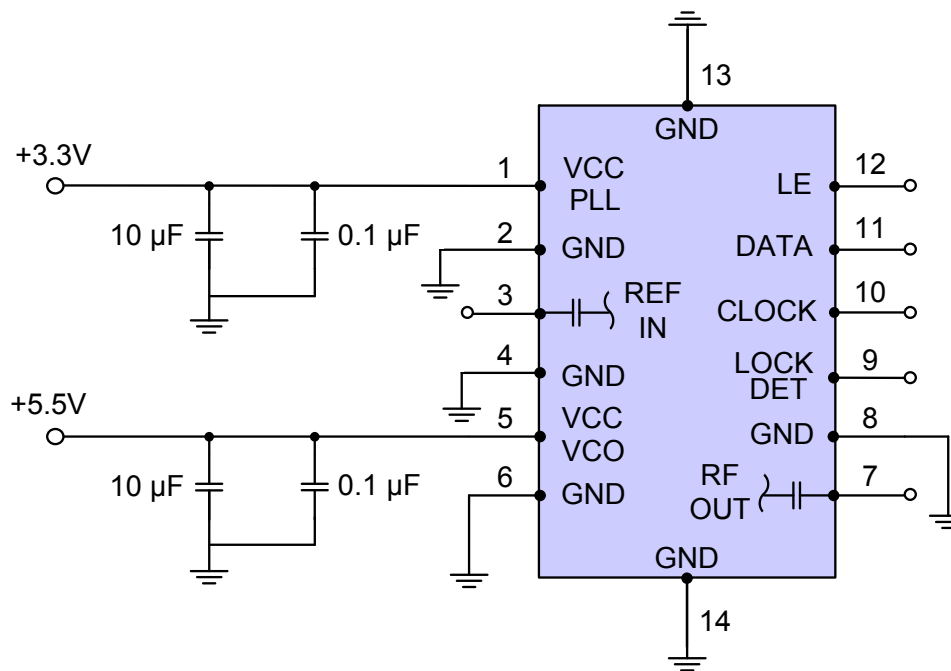

IF/RF MICROWAVE COMPONENTS • ISO 9001 ISO 14001 AS9100 CERTIFIED RoHS compliant
 P.O. Box 350166, Brooklyn, New York 11235-0003 (718) 934-4500 Fax (718) 332-4661



The Design Engineers Search Engine finds the model you need, Instantly • For detailed performance specs & shopping online see



Notes: 1. Performance and quality attributes and conditions not expressly stated in this specification sheet are intended to be excluded and do not form a part of this specification sheet. 2. Electrical specifications and performance data contained herein are based on Mini-Circuit's applicable established test performance criteria and measurement instructions. 3. The parts covered by this specification sheet are subject to Mini-Circuits standard limited warranty and terms and conditions (collectively, "Standard Terms"); Purchasers of this part are entitled to the rights and benefits contained therein. For a full statement of the Standard Terms and the exclusive rights and remedies thereunder, please visit Mini-Circuits' website at www.minicircuits.com/MCLStore/terms.jsp.

Device Marking

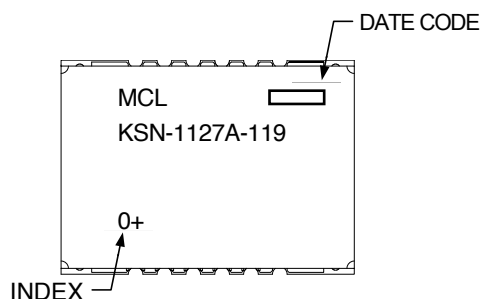

Additional Detailed Technical Information

Additional information is available on our web site. To access this information enter the model number on our web site home page.

Case Style: DK1042

Tape & Reel: TR-F28

Suggested Layout for PCB Design: PL-249

Evaluation Board: TB-567-4+

Environment Ratings: ENV03T2



IF/RF MICROWAVE COMPONENTS • ISO 9001 ISO 14001 AS9100 CERTIFIED RoHS compliant
P.O. Box 350166, Brooklyn, New York 11235-0003 (718) 934-4500 Fax (718) 332-4661



The Design Engineers Search Engine finds the model you need, Instantly • For detailed performance specs & shopping online see



Notes: 1. Performance and quality attributes and conditions not expressly stated in this specification sheet are intended to be excluded and do not form a part of this specification sheet. 2. Electrical specifications and performance data contained herein are based on Mini-Circuit's applicable established test performance criteria and measurement instructions. 3. The parts covered by this specification sheet are subject to Mini-Circuits standard limited warranty and terms and conditions (collectively, "Standard Terms"); Purchasers of this part are entitled to the rights and benefits contained therein. For a full statement of the Standard Terms and the exclusive rights and remedies thereunder, please visit Mini-Circuits' website at www.minicircuits.com/MCLStore/terms.jsp.