

Surface Mount I&Q Modulator

50Ω LO Drive +10 dBm 1800 to 2000 MHz

IQBG-2000A+

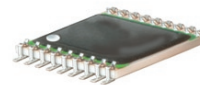

Unit may be marked IQBG-2000A+ or IQBG-2000A-4

CASE STYLE: SM20A
PRICE: \$24.95 ea. QTY (1-9)

+ RoHS compliant in accordance with EU Directive (2002/95/EC)

The +Suffix has been added in order to identify RoHS Compliance. See our web site for RoHS Compliance methodologies and qualifications.

Maximum Ratings

Operating Temperature	-40°C to 85°C
Storage Temperature	-55°C to 100°C
LO Power	50 mW
I & Q Current	40mA

Permanent damage may occur if any of these limits are exceeded.

Pin Connections

LO (carrier)	9
RF (signal)	14
I (0°)(ref.)	10
Q (90°)*	18
GROUND	1,2,3,4,5,6,7,8,11,12,13,15,16,17

*Q= I +90° for lower sideband suppression

Outline Drawing

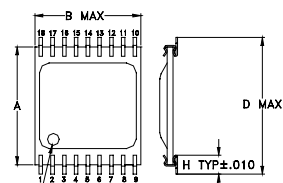

Suggested Layout.
Tolerance to be within ±.002
Each ground pin shall have footprint per view "A". All ground pads shall be connected to each other per view "B".

PCB Land Pattern

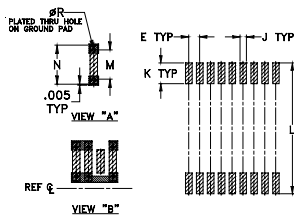

Outline Dimensions (inch/mm)

A	B	C	D	E	F	G	H	J
.500	.460	.095	.575	.050	.015	.025	.070	.030
12.70	11.68	2.41	14.61	1.27	0.38	0.64	1.78	0.76
K	L	M	N	P	Q	R	wt	
.095	.600	.120	.160	--	--	.012	grams	
2.41	15.24	3.05	4.06	--	--	0.30	0.5	

Demo Board MCL P/N: TB-196 Suggested PCB Layout (PL-222)

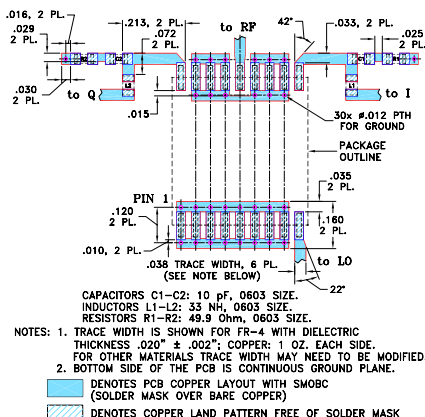

Features

- excellent sideband rejection, 34 dB typ.
- excellent temperature stability
- low noise floor
- low height
- aqueous washable
- protected by US patents, 5,534,830 and 5,745,017

Applications

- communications systems

Modulator Electrical Specifications

FREQUENCY (MHz)		CONVERSION LOSS (dB)		CARRIER REJECTION (-dBc)		SIDE BAND REJECTION (-dBc)		HARMONIC SUPPRESSION (dBc)					
RF (SIGNAL) LO (CARRIER)		I&Q						3XI/Q		5XI/Q			
f _L	f _U	Min.	Max.	\bar{x}	Max.	Typ.	Min.	Typ.	Min.	Typ.	Min.		
1800	2000	DC	10	7.5	9.0	30	20	34	28	50	45	70	50

Typical Performance Data

Carrier Frequency (MHz)	Conversion Loss (\bar{x} (dB), σ (dB))	Sideband Rejection LSB (-dBc)	Carrier Rejection (-dBc)	3rd. Harmonic Suppression (L - 3 I, L + 3 I) (-dBc)	
1800	7.25 / 0.09	36.50	24.72	48.80	78.04
1850	7.45 / 0.11	37.50	26.41	50.52	73.47
1900	7.66 / 0.08	37.55	26.47	53.47	76.07
1950	8.02 / 0.05	36.31	28.23	54.98	69.41
2000	8.30 / 0.11	33.57	28.80	56.50	72.13

Typical 5th Harmonic Suppression performance: at noise floor, -79 dBc

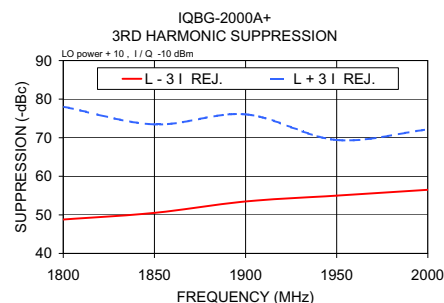
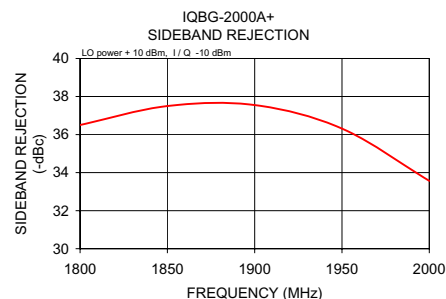
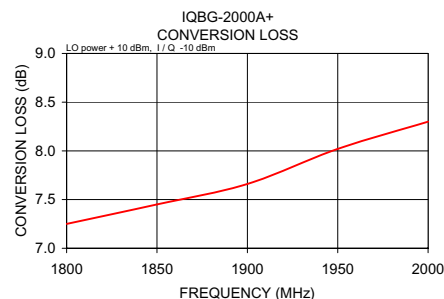

Recommended IF Diplexer

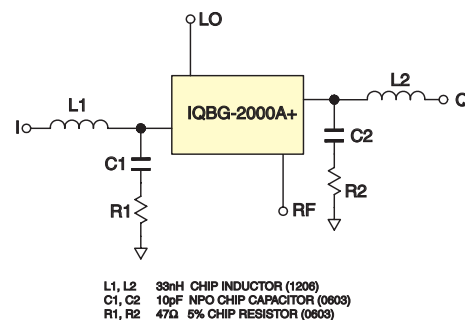

Mini-Circuits
ISO 9001 ISO 14001 AS 9100 CERTIFIED

For detailed performance specs & shopping online see web site

P.O. Box 350166, Brooklyn, New York 11235-0003 (718) 934-4500 Fax (718) 332-4661 The Design Engineers Search Engine Provides ACTUAL Data Instantly at minicircuits.com

Notes: 1. Performance and quality attributes and conditions not expressly stated in this specification sheet are intended to be excluded and do not form a part of this specification sheet. 2. Electrical specifications and performance data contained herein are based on Mini-Circuit's applicable established test performance criteria and measurement instructions. 3. The parts covered by this specification sheet are subject to Mini-Circuits standard limited warranty and terms and conditions (collectively, "Standard Terms"); Purchasers of this part are entitled to the rights and benefits contained therein. For a full statement of the Standard Terms and the exclusive rights and remedies thereunder, please visit Mini-Circuits' website at www.minicircuits.com/MCLStore/terms.jsp.

REV. D
M121018
IQBG-2000A+
EDB-0204B
BC/TD/CP/AM
090108