

Ceramic High Pass Filter

HFCN-1810

50Ω 1950 to 4750 MHz



CASE STYLE: FV1206

Maximum Ratings

Operating Temperature	-55°C to 100°C
Storage Temperature	-55°C to 100°C
RF Power Input*	7W max. at 25°C

* Passband rating, derate linearly to 3W at 100°C ambient. Permanent damage may occur if any of these limits are exceeded.

Pin Connections

RF IN	1
RF OUT	3
GROUND	2,4

Outline Drawing

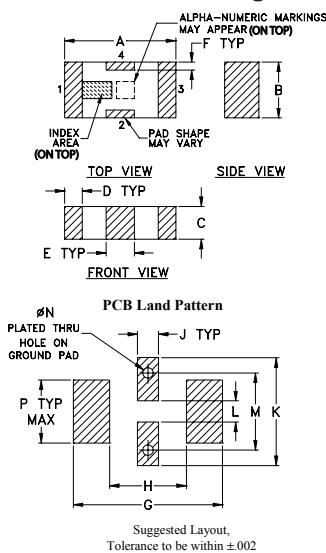

Outline Dimensions (inch)

A	B	C	D	E	F	G
.126	.063	.037	.020	.032	.009	.169
3.20	1.60	0.94	0.51	0.81	0.23	4.29

H	J	K	L	M	N	P	wt
.087	.024	.122	.024	.087	.012	.071	grams
2.21	0.61	3.10	0.61	2.21	0.30	1.80	.020

Demo Board MCL P/N: TB-270
Suggested PCB Layout (PL-137)

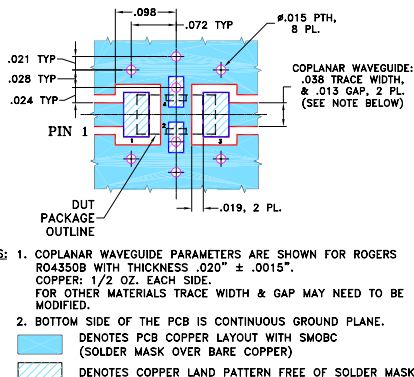

NOTES: 1. COPLANAR WAVEGUIDE PARAMETERS ARE SHOWN FOR ROGERS RO4350B WITH THICKNESS .020" ± .0015". COPPER: 1/2 OZ. EACH SIDE. FOR OTHER MATERIALS TRACE WIDTH & GAP MAY NEED TO BE MODIFIED.

2. BOTTOM SIDE OF THE PCB IS CONTINUOUS GROUND PLANE.
- DENOTES PCB COPPER LAYOUT WITH SMOBC (SOLDER MASK OVER BARE COPPER)
 - DENOTES COPPER LAND PATTERN FREE OF SOLDER MASK

Notes

- A. Performance and quality attributes and conditions not expressly stated in this specification document are intended to be excluded and do not form a part of this specification document.
 B. Electrical specifications and performance data contained in this specification document are based on Mini-Circuit's applicable established test performance criteria and measurement instructions.
 C. The parts covered by this specification document are subject to Mini-Circuits standard limited warranty and terms and conditions (collectively, "Standard Terms"); Purchasers of this part are entitled to the rights and benefits contained therein. For a full statement of the Standard Terms and the exclusive rights and remedies thereunder, please visit Mini-Circuits' website at www.minicircuits.com/MCLStore/terms.jsp

Features

- low cost
- small size
- 7 sections
- temperature stable
- hermetically sealed
- LTCC construction
- excellent power handling, 7W

Applications

- sub-harmonic rejection
- transmitters/receivers
- lab use

Electrical Specifications^(1,2) at 25°C

STOP BAND (MHz)		f _{co} , MHz	PASSBAND (MHz)		VSWR (:1) Typ.	POWER INPUT (W)	NO. OF SECTIONS
Min.		Nom.	Max.		Frequency (MHz)		
(loss > 40 dB)	(loss > 20 dB)	(loss 3 dB) Typ.	(loss < 1.3 dB) Max.	(loss < 2 dB) Typ.	Stopband 1.5:1		
1100	1480	1810	2250-3850	1950-4750	20:1	2250-3750	7

(1) In Application where DC voltage is present at either input or output ports, coupling capacitors are required. Alternatively, Mini-Circuits' "D" suffix version of this model will provide >100 MOhm isolation to ground.

(2) Measured on Mini-Circuits Characterization Test Board TB-270.

typical frequency response

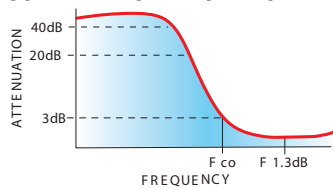

electrical schematic

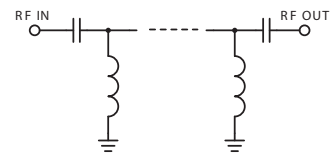

Typical Performance Data at 25°C

Frequency (MHz)	Insertion Loss (dB)	VSWR (:1)
1.00	94.72	1737.18
100.00	74.52	1737.18
1100.00	45.78	66.82
1480.00	32.05	26.33
1650.00	14.33	12.01
1750.00	6.57	4.61
1810.00	3.63	2.52
1950.00	1.52	1.57
2250.00	0.78	1.33
3750.00	0.69	1.53
3850.00	0.74	1.61
4750.00	1.66	2.67
5500.00	2.71	3.76
7000.00	4.89	6.30

