

# Ceramic High Pass Filter

## HFCN-1760

50Ω 1900 to 5500 MHz



CASE STYLE: FV1206

Available Tape and Reel at no extra cost

Reel Size	Devices/Reel
7"	20, 50, 100, 200, 500, 1000, 3000

### Maximum Ratings

Operating Temperature	-55°C to 100°C
Storage Temperature	-55°C to 100°C
RF Power Input*	7W max. at 25°C

\* Passband rating, derate linearly to 3W at 100°C ambient. Permanent damage may occur if any of these limits are exceeded.

### Pin Connections

RF IN	1
RF OUT	3
GROUND	2,4

### Outline Drawing

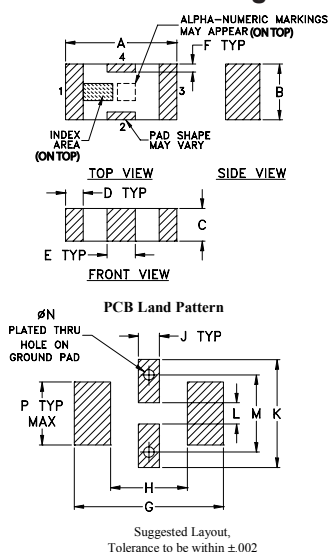

### Outline Dimensions (inch)

A	B	C	D	E	F	G
.126	.063	.037	.020	.032	.009	.169
3.20	1.60	0.94	0.51	0.81	0.23	4.29

H	J	K	L	M	N	P	wt
.087	.024	.122	.024	.087	.012	.071	grams
2.21	0.61	3.10	0.61	2.21	0.30	1.80	.020

### Demo Board MCL P/N: TB-270 Suggested PCB Layout (PL-137)

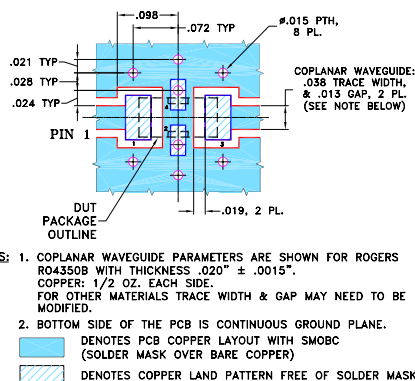

- NOTES:**
- COPLANAR WAVEGUIDE PARAMETERS ARE SHOWN FOR ROGERS RO4350B WITH THICKNESS .020" ± .0015". COPPER: 1/2 OZ. EACH SIDE. FOR OTHER MATERIALS TRACE WIDTH & GAP MAY NEED TO BE MODIFIED.
  - BOTTOM SIDE OF THE PCB IS CONTINUOUS GROUND PLANE.
    - DENOTES PCB COPPER LAYOUT WITH SMOBC (SOLDER MASK OVER BARE COPPER)
    - DENOTES COPPER LAND PATTERN FREE OF SOLDER MASK

### Notes

- A. Performance and quality attributes and conditions not expressly stated in this specification document are intended to be excluded and do not form a part of this specification document.  
 B. Electrical specifications and performance data contained in this specification document are based on Mini-Circuit's applicable established test performance criteria and measurement instructions.  
 C. The parts covered by this specification document are subject to Mini-Circuit's standard limited warranty and terms and conditions (collectively, "Standard Terms"); Purchasers of this part are entitled to the rights and benefits contained therein. For a full statement of the Standard Terms and the exclusive rights and remedies thereunder, please visit Mini-Circuit's website at [www.minicircuits.com/MCLStore/terms.jsp](http://www.minicircuits.com/MCLStore/terms.jsp)

### Features

- low cost
- small size
- 7 sections
- temperature stable
- hermetically sealed
- LTCC construction
- excellent power handling, 7W

### Applications

- sub-harmonic rejection
- transmitters/receivers
- lab use

### Electrical Specifications<sup>(1,2)</sup> at 25°C

STOP BAND (MHz) Min.	f <sub>co</sub> , MHz Nom.	PASSBAND (MHz)	VSWR (:1) Typ.	POWER INPUT (W)	NO. OF SECTIONS
(loss > 40 dB)	(loss 3 dB) Typ.	(loss < 1.3 dB) (loss < 2 dB) Max. Typ.	Frequency (MHz) Stopband 1.5:1		
950	1760	2100-5200 1900-5500	20:1 2200-4500	7	7

(1) In Application where DC voltage is present at either input or output ports, coupling capacitors are required.

(2) Measured on Mini-Circuits Characterization Test Board TB-270.

### typical frequency response

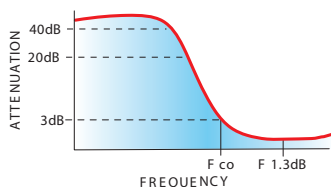

### electrical schematic

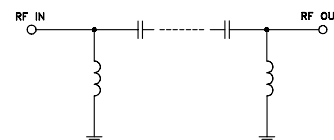

### Typical Performance Data at 25°C

Frequency (MHz)	Insertion Loss (dB)	VSWR (:1)
1.00	94.01	347.44
100.00	79.27	102.19
950.00	44.24	38.61
1230.00	23.99	27.59
1400.00	13.10	15.67
1500.00	7.92	8.43
1700.00	2.49	2.72
1760.00	1.87	2.24
1900.00	1.18	1.67
2100.00	0.79	1.34
2200.00	0.67	1.23
4500.00	0.58	1.16
5200.00	0.98	1.73
5500.00	1.31	2.12
6500.00	2.90	3.81
9000.00	4.70	5.27

