

Ceramic High Pass Filter

HFCN-1200

50Ω 1220 to 4600 MHz



CASE STYLE: FV1206

Maximum Ratings

| | |
|-----------------------|-----------------|
| Operating Temperature | -55°C to 100°C |
| Storage Temperature | -55°C to 100°C |
| RF Power Input* | 7W max. at 25°C |

* Passband rating, derate linearly to 3W at 100°C ambient. Permanent damage may occur if any of these limits are exceeded.

Pin Connections

| | |
|--------|-----|
| RF IN | 1 |
| RF OUT | 3 |
| GROUND | 2,4 |

Outline Drawing

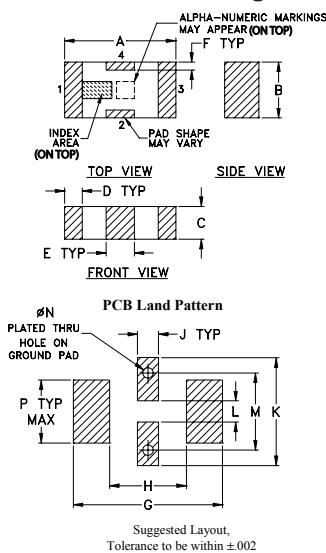

Outline Dimensions (inch)

| A | B | C | D | E | F | G |
|------|------|------|------|------|------|------|
| .126 | .063 | .037 | .020 | .032 | .009 | .169 |
| 3.20 | 1.60 | 0.94 | 0.51 | 0.81 | 0.23 | 4.29 |

| H | J | K | L | M | N | P | wt |
|------|------|------|------|------|------|------|-------|
| .087 | .024 | .122 | .024 | .087 | .012 | .071 | grams |
| 2.21 | 0.61 | 3.10 | 0.61 | 2.21 | 0.30 | 1.80 | .020 |

Demo Board MCL P/N: TB-270 Suggested PCB Layout (PL-137)

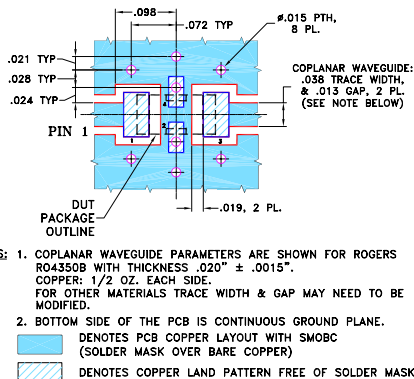

NOTES: 1. COPLANAR WAVEGUIDE PARAMETERS ARE SHOWN FOR ROGERS RO4350B WITH THICKNESS .020" ± .0015". COPPER: 1/2 OZ. EACH SIDE. FOR OTHER MATERIALS TRACE WIDTH & GAP MAY NEED TO BE MODIFIED.

2. BOTTOM SIDE OF THE PCB IS CONTINUOUS GROUND PLANE.
- DENOTES PCB COPPER LAYOUT WITH SMOBC (SOLDER MASK OVER BARE COPPER)
 - DENOTES COPPER LAND PATTERN FREE OF SOLDER MASK

Notes

A. Performance and quality attributes and conditions not expressly stated in this specification document are intended to be excluded and do not form a part of this specification document.
 B. Electrical specifications and performance data contained in this specification document are based on Mini-Circuit's applicable established test performance criteria and measurement instructions.
 C. The parts covered by this specification document are subject to Mini-Circuit's standard limited warranty and terms and conditions (collectively, "Standard Terms"); Purchasers of this part are entitled to the rights and benefits contained therein. For a full statement of the Standard Terms and the exclusive rights and remedies thereunder, please visit Mini-Circuit's website at www.minicircuits.com/MCLStore/terms.jsp

Features

- low cost
- small size
- 7 sections
- temperature stable
- hermetically sealed
- LTCC construction
- excellent power handling, 7W

Applications

- sub-harmonic rejection
- transmitters/receivers
- lab use

Electrical Specifications^(1,2) at 25°C

| STOP BAND (MHz) | | f _{co} , MHz Nom. | PASSBAND (MHz) | | VSWR (:1) Typ. | POWER INPUT (W) | NO. OF SECTIONS |
|-----------------|----------------|----------------------------|----------------------|--------------------|--------------------------------|-----------------|-----------------|
| (loss > 40 dB) | (loss > 20 dB) | (loss 3 dB) Typ. | (loss < 1.3 dB) Max. | (loss < 2 dB) Typ. | Frequency (MHz) Stopband 1.5:1 | | |
| 750 | 910 | 1180 | 1380-4000 | 1220-4600 | 20:1 | 1300-3200 | 7 |

(1) In Application where DC voltage is present at either input or output ports, coupling capacitors are required. Alternatively, Mini-Circuit's "D" suffix version of this model will provide >100 MOhm isolation to ground.
 (2) Measured on Mini-Circuit's Characterization Test Board TB-270.

typical frequency response

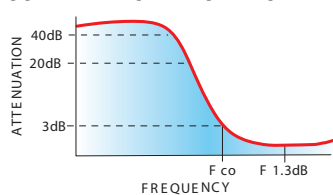

electrical schematic

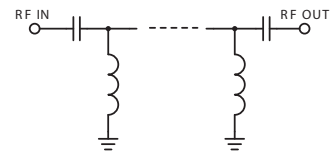

Typical Performance Data at 25°C

| Frequency (MHz) | Insertion Loss (dB) | VSWR (:1) |
|-----------------|---------------------|-----------|
| 1.00 | 104.60 | 1737.18 |
| 100.00 | 76.44 | 1737.18 |
| 750.00 | 63.39 | 56.04 |
| 910.00 | 30.29 | 32.79 |
| 1050.00 | 13.74 | 12.35 |
| 1130.00 | 6.09 | 4.53 |
| 1180.00 | 3.15 | 2.35 |
| 1220.00 | 2.01 | 1.65 |
| 1300.00 | 1.24 | 1.39 |
| 1380.00 | 0.98 | 1.39 |
| 3200.00 | 0.44 | 1.33 |
| 4000.00 | 0.93 | 2.01 |
| 4600.00 | 1.62 | 2.73 |
| 7000.00 | 4.86 | 6.63 |

