

5 Volt-Surface Mount

Monolithic Amplifier

DC-7 GHz

Product Features

- Gain, 10 dB typ. at 100 MHz
- High Pout, P1dB 19.1 dBm typ.
- High IP3, 42 dBm typ. at 100 MHz
- Ruggedized design
- Fixed 5V operation
- Unconditionally stable
- Excellent ESD Protection
- Transient protected, US patent 6,943,629



GVA-81+

CASE STYLE: DF782
PRICE: \$1.82 ea. QTY. (30)

+ RoHS compliant in accordance with EU Directive (2002/95/EC)

The +Suffix has been added in order to identify RoHS Compliance. See our web site for RoHS Compliance methodologies and qualifications.

Typical Applications

- Base station infrastructure
- Portable Wireless
- CATV & DBS
- MMDS & Wireless LAN
- LTE

General Description

GVA-81+ (RoHS compliant) is a wideband amplifier offering high dynamic range. Lead finish is SnAgNi. It has repeatable performance from lot to lot and is enclosed in a SOT-89 package. It uses patented Transient Protected Darlington configuration and is fabricated using InGaP HBT technology.

simplified schematic and pin description

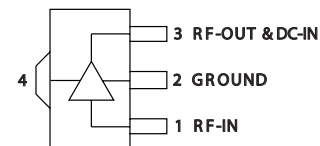
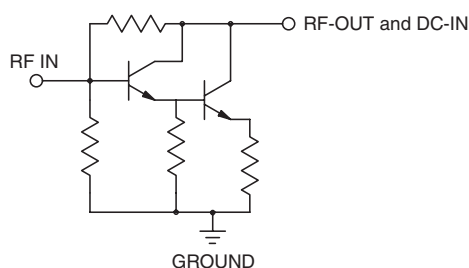

Function	Pin Number	Description
RF IN	1	RF input pin. This pin requires the use of an external DC blocking capacitor chosen for the frequency of operation.
RF-OUT and DC-IN	3	RF output and bias pin. DC voltage is present on this pin; therefore a DC blocking capacitor is necessary for proper operation. An RF choke is needed to feed DC bias without loss of RF signal due to the bias connection, as shown in "Recommended Application Circuit", Fig. 2
GND	2,4	Connections to ground. Use via holes as shown in "Suggested Layout for PCB Design" to reduce ground path inductance for best performance.

Mini-Circuits
ISO 9001 ISO 14001 AS 9100 CERTIFIED

P.O. Box 350166, Brooklyn, New York 11235-0003 (718) 934-4500 Fax (718) 332-4661 The Design Engineers Search Engine

IF/RF MICROWAVE COMPONENTS

For detailed performance specs & shopping online see web site



Provides ACTUAL Data Instantly at minicircuits.com

Notes: 1. Performance and quality attributes and conditions not expressly stated in this specification sheet are intended to be excluded and do not form a part of this specification sheet. 2. Electrical specifications and performance data contained herein are based on Mini-Circuit's applicable established test performance criteria and measurement instructions. 3. The parts covered by this specification sheet are subject to Mini-Circuits standard limited warranty and terms and conditions (collectively, "Standard Terms"); Purchasers of this part are entitled to the rights and benefits contained therein. For a full statement of the Standard Terms and the exclusive rights and remedies thereunder, please visit Mini-Circuits' website at www.minicircuits.com/MCLStore/terms.jsp.

REV. OR
M122194
GVA-81+
ED-12353/2
091117
Page 1 of 5

Electrical Specifications⁽¹⁾ at 25°C and 5V, unless noted

Parameter	Condition (GHz)	Min.	Typ.	Max.	Units
Frequency Range ⁽²⁾		DC		7	GHz
Gain	0.1	9.5	10.5	11.5	dB
	1.0		10.5		
	2.0	8.8	10.0	11.0	
	3.0		9.3		
	4.0	7.5	8.7	10.0	
	6.0		8.1		
	7.0		7.6		
Magnitude of Gain Variation versus Temperature ⁽³⁾ (values are negative)	0.1		0.0005	0.005	dB/°C
	1.0		0.0010		
	2.0		0.0016		
	3.0		0.0020		
	4.0		0.0025		
	6.0		0.0036		
	7.0		0.0063		
Input Return Loss	0.1	14.0	38.0		dB
	1.0		27.0		
	2.0		20.1		
	3.0		17.4		
	4.0		16.9		
	6.0		18.5		
	7.0		14.3		
Output Return Loss	0.1	12.0	21.4		dB
	1.0		20.6		
	2.0		17.4		
	3.0		14.5		
	4.0		13.1		
	6.0		14.8		
	7.0		13.2		
Reverse Isolation	2.0		20.8		dB
Output Power @ 1 dB compression	0.1	17.5	19.1		dBm
	1.0	17.5	19.1		
	2.0	17.5	19.7		
	3.0		19.7		
	4.0		19.4		
	6.0		17.7		
	7.0		17.7		
Output IP3	0.1	32.0	42.0		dBm
	1.0		38.3		
	2.0		36.6		
	3.0		35.0		
	4.0		33.2		
	6.0		31.1		
	7.0		31.1		
Noise Figure	0.1		7.3	8.6	dB
	1.0		7.3		
	2.0		7.4		
	3.0		7.6		
	4.0		7.7		
	6.0		8.3		
	7.0		8.9		
Group Delay	2.0		98		psec
Device Operating Voltage		4.8	5.0	5.2	V
Device Operating Current		93	103	112	mA
Device Current Variation vs. Temperature			62		µA/°C
Device Current Variation vs. Voltage			0.036		mA/mV
Thermal Resistance, junction-to-ground lead			65		°C/W

⁽¹⁾ Measured on Mini-Circuits test board TB-313. See Characterization Test Circuit (Fig. 1)

⁽²⁾ Guaranteed specification DC-7 GHz. *Low frequency cut off determined by external coupling capacitors and RF Choke (RFC).

⁽³⁾ (Gain at 85°C - Gain at -45°C)/130



For detailed performance specs & shopping online see web site

P.O. Box 350166, Brooklyn, New York 11235-0003 (718) 934-4500 Fax (718) 332-4661 The Design Engineers Search Engine Provides ACTUAL Data Instantly at minicircuits.com

IF/RF MICROWAVE COMPONENTS

Notes: 1. Performance and quality attributes and conditions not expressly stated in this specification sheet are intended to be excluded and do not form a part of this specification sheet. 2. Electrical specifications and performance data contained herein are based on Mini-Circuit's applicable established test performance criteria and measurement instructions. 3. The parts covered by this specification sheet are subject to Mini-Circuits standard limited warranty and terms and conditions (collectively, "Standard Terms"); Purchasers of this part are entitled to the rights and benefits contained therein. For a full statement of the Standard Terms and the exclusive rights and remedies thereunder, please visit Mini-Circuits' website at www.minicircuits.com/MCLStore/terms.jsp.

Absolute Maximum Ratings

Parameter	Ratings
Operating Temperature (ground lead)	-40°C to 85°C
Storage Temperature	-65°C to 150°C
Operating Current at 5V	160mA
Power Dissipation	1.0W
Input Power	20 dBm
DC Voltage on Pin 3	5.8V

Note:
 Permanent damage may occur if any of these limits are exceeded.
 Electrical maximum ratings are not intended for continuous normal operation.

Characterization Test Circuit

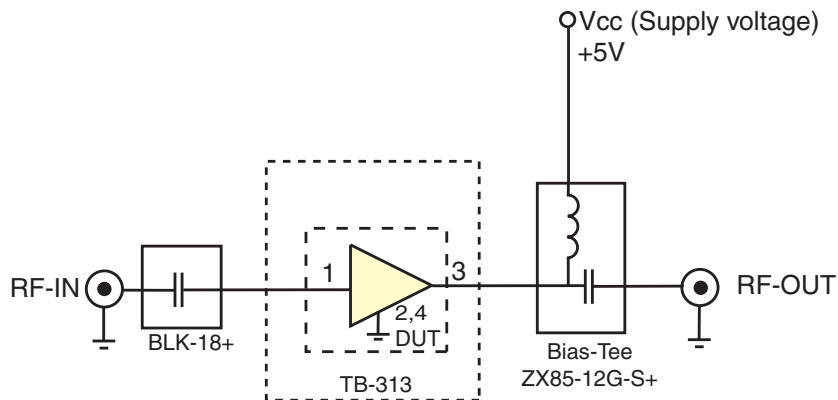
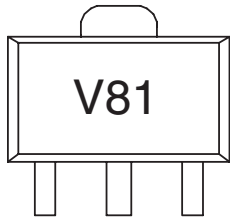

Fig 1. Block Diagram of Test Circuit used for characterization. (DUT soldered on Mini-Circuits Test Board TB-313)
 Gain, Output power at 1dB compression (P1 dB) and output IP3 (OIP3) are measured using R&S Network Analyzer ZVA-24.
 Noise Figure measured using Agilent's N5242A PNA-X microwave network analyzer.

- Conditions:**
1. Gain and Return loss: Pin= -25dBm
 2. Output IP3 (OIP3): Two tones, spaced 1 MHz apart, 0 dBm/tone at output.

Product Marking



Additional Detailed Technical Information

Additional information is available on our web site. To access this information enter the model number on our web site home page.

Performance data, graphs, s-parameter (S2P FILES) data set (.zip file)

Case Style: DF782 (SOT 89)

Plastic package, exposed paddle, lead finish: tin/silver/nickel

Tape & Reel: F55

Suggested Layout for PCB Design: PL-255

Evaluation Board: TB-410-81+

Environmental Ratings: ENV08T1

Recommended Application Circuit

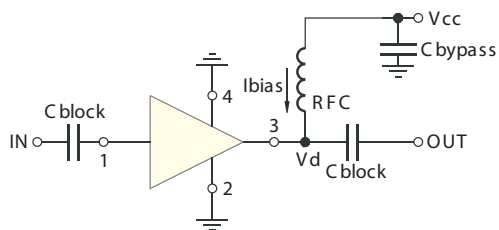

Fig 2. Test Board includes case, connectors, and components soldered to PCB

ESD Rating

Human Body Model (HBM): Class 1C (1000v to < 2000v) in accordance with ANSI/ESD STM 5.1 - 2001

Machine Model (MM): Class M2 (100V to < 200V) in accordance with ANSI/ESD STM 5.2 - 1999

MSL Rating

Moisture Sensitivity: MSL1 in accordance with IPC/JEDECJ-STD-020D

MSL Test Flow Chart

