



Millimeter Wave PIN Diode Attenuator/Modulator

[How to Buy](#) Application Notes for [Microwave Attenuator](#)



MODEL 1959

The Model 1959 is a current controlled attenuator/modulator that provides a minimum of 50 dB of attenuation over the frequency range of 18 to 40 GHz. As shown in figure 1 below, the RF circuit uses two shunt arrays of PIN diodes and two quadrature hybrid couplers. The quadrature hybrids are of a unique GMC microstrip design which are integrated with the diode arrays to yield a minimal package size.

- Absorptive
- Current or voltage controlled
- 18 to 40 GHz frequency range
- High performance MIC quadrature hybrid design
- High speed

MODEL D1959

The Model D1959 voltage-controlled linearized attenuator/modulator is an integrated assembly of a Model 1959 and a hybridized driver circuit which provides a nominal transfer function of 10 dB per volt. (See figure 2 below.)

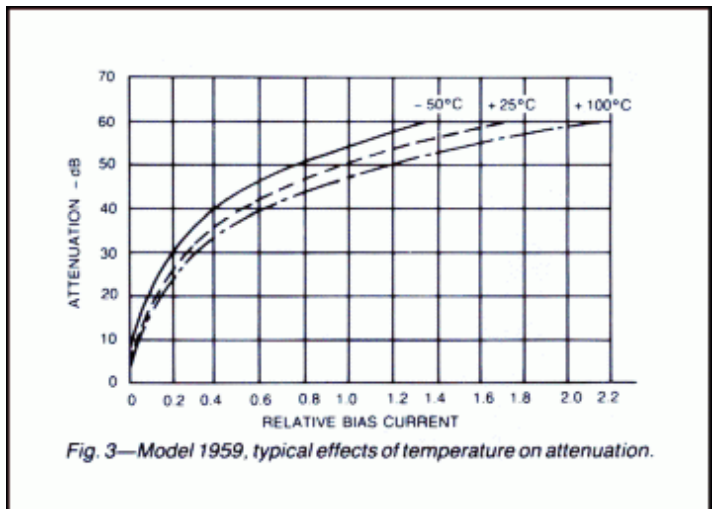
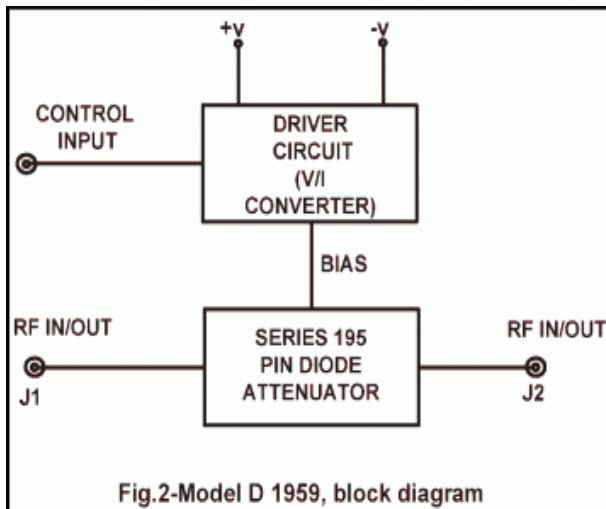
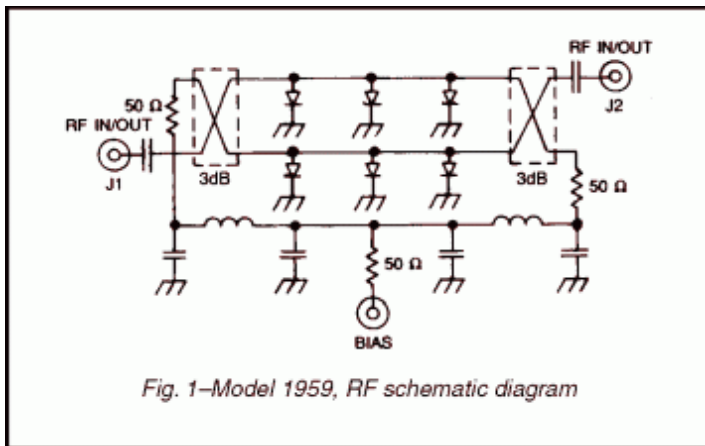
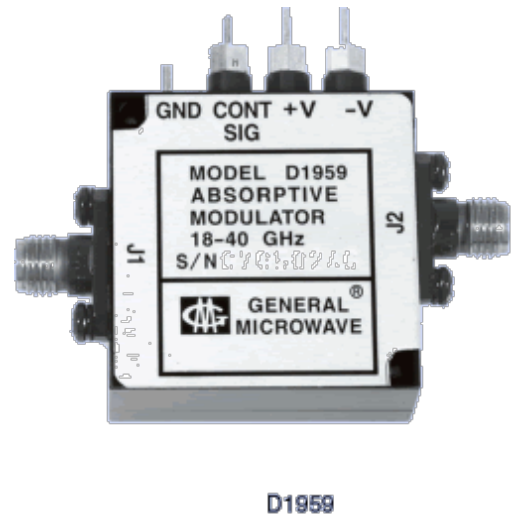

PERFORMANCE CHARACTERISTICS

MODEL	FREQUENCY RANGE (GHz)	MAX. INSERTION LOSS (db)	MAX. VSWR	FLATNESS (± dB) AT MEAN ATTENUATION LEVELS UP TO			
				10 dB	20 dB	40 dB	50 dB

1959	18-26.5	3.6	2.2	1.3	2.2	3.4	4.0
	26.5-36	4.1					
	36-40	4.7					
D1959	18-26.5	4.1	2.2	1.3	2.2	3.4	4.0
	26.5-36	4.6					
	36-40	5.2					

COMMON TO BOTH MODELS 1959 and D1959

Mean Attenuation Range 50 dB
Monotonicity Guaranteed
Power Handling Capability
 Without Performance
 Degradation 10 mW cw or peak
 Survival Power 0.2W average, 5W peak
 (11 μ sec max pulse width)

MODEL 1959

Rise and Fall Times
 Rise Time 75 nsec max
 Fall Time 20 nsec max(1)
Bias Current for Maximum Attenuation 15 to 70 mA
Temperature Effects See figure 3

MODEL D1959

Accuracy of Attenuation
 0 to 30 dB ± 0.5 dB
 30 to 50 dB ± 1.0 dB
Temperature Coefficient ± 0.025 dB/ $^{\circ}$ C
Switching Characteristics
 ON Time 1,600 nsec
 OFF Time 100 nsec max(1)
Nominal Control Voltage Characteristics
 Operating 0 to +5V
 Transfer Function 10 dB/volt
 Input Impedance 10 k ohms
Modulation Bandwidth
 Small Signal 5 MHz
 Large Signal 2 MHz
Power Supply Requirements + 12V $\pm 5\%$, 120 mA
 - 12V $\pm 5\%$, 50 mA
Power Supply Rejection Less than 0.1 dB/Volt
 change in either supply

ENVIRONMENTAL RATINGS

Operating Temperature Range
 Model 1959 -54oC to +125oC
 Model D1959 -54oC to +110oC
Non-Operating Temperature Range -65oC to +125oC
Humidity MIL-STD-202F, Method 103B,
 Cond. B (96 hrs. at 95%)
Shock MIL-STD-202F, Method 213B,
 Cond. B (75G, 6 msec)
Vibration MIL-STD-202F, Method 204D,
 Cond. B. (.06" double
 amplitude or 15G, whichever is
 less)
Altitude MIL-STD-2002F, Method 105C,
 Cond. B (50,000 ft.)
Temp. Cycling MIL-STD-202F, Method 107D,
 Cond. A, 5 cycles

AVAILABLE OPTIONS

Option No	Description
3	SMA female bias/control connectors
7	Type K male RF connectors
10	One type K male (J1) and one type K femail (j2) RF connectors
61(1)	20 dB/volt transfer function with 0 to +3V control signal input
62(1)	± 15 volts operation
64	SMC male bias/control connectors
64A	A SMB male bias/control connectors

(1) Not applicable for units without drivers

(1) For attenuation steps of 10 db or more

DIMENSIONS AND WEIGHT

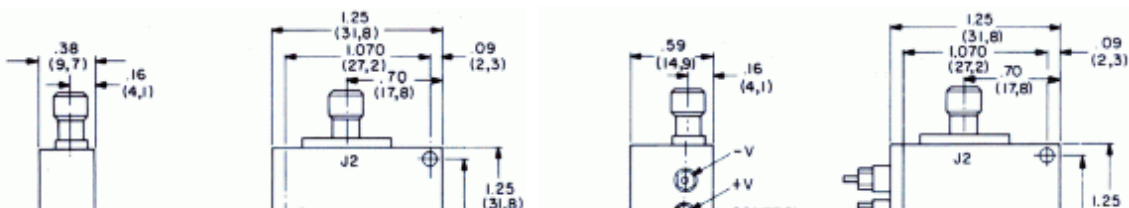

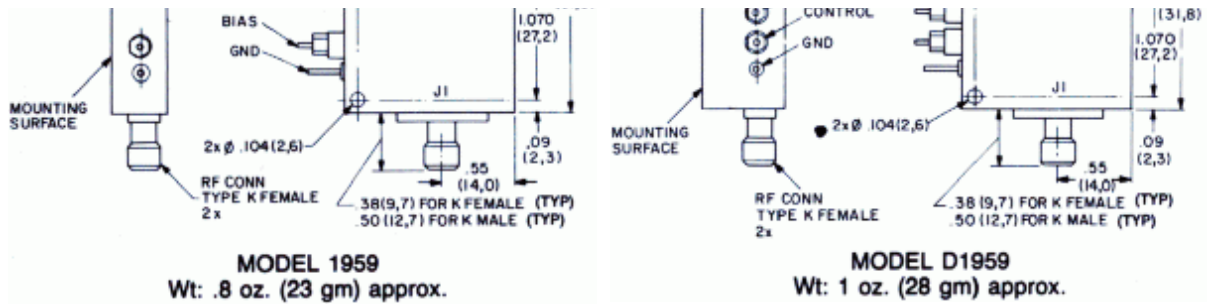

Dimensional Tolerances, unless otherwise indicated: $xx \pm .02$; $xx \pm .005$

Contact us

Herley - General Microwave specializes in developing and producing customized [microwave components](#) and [millimeter wave products](#) for the defense and aerospace industries as well as for non-defense applications such as communication systems. Herley General Microwave produces the industry standard General Microwave line of off-the-shelf catalog RF component^x. If you are looking for a [Solid State Power Amplifier](#), [Microwave Synthesizer](#) or other [microwave osillators](#), Microwave Receiver, [RF Switch](#), [Microwave attenuator](#), Microwave Limiter, [Microwave Phase Shifter](#), or [Microwave IQ Vector Modulator](#) we can produce components meeting your requirements at a very competitive price. We also produce high quality customized [Integrated Microwave Assemblies](#) such as Up and Down Converters, DLVAs, Beam Forming Networks, Front Ends, or Switched Bank Filters, that can be used in a wide variety of demanding applications. [Herley General Microwave \(HGMI\)](#), a subsidiary of [Herley Industries](#) provides solutions for electronic warfare systems, Phased Array Radar systems, electronic warfare simulators, test Equipment and test Systems and other defense and non-defense systems. We look forward to working with you, so please [contact us](#) today.

```
var _gaq = _gaq || [];
_gaq.push(['_setAccount', 'UA-16324217-1']);
_gaq.push(['_trackPageview']);
(function() {
  var ga = document.createElement('script');
  ga.type = 'text/javascript';
  ga.async = true;
  ga.src = ('https:' == document.location.protocol ?
  'https://ssl' : 'http://www') + '.google-analytics.com/ga.js';
  var s = document.getElementsByTagName('script')[0];
  s.parentNode.insertBefore(ga, s);
})();
```