

Ultra Low Noise

High Linearity MMIC Amplifier

CMA-545+

50Ω 0.05 to 6 GHz

The Big Deal

- Ceramic, Hermetically sealed, Nitrogen Filled
- Low profile case, .045" high
- Ultra Low Noise Figure, 0.8 dB typ.
- Output Power, +20dBm at 1GHz



CASE STYLE: DL1721

Product Overview

Mini-Circuits CMA-545+ delivers a unique combination of ultra low noise and high IP3 performance, ideal for sensitive receiver applications. The E-PHEMT amplifier die is bonded to a multilayer integrated LTCC substrate, and then hermetically sealed under a controlled nitrogen atmosphere with gold-plated covers and eutectic AuSn solder. As a result, this rugged amplifier has met MIL requirements for gross leak, fine leak, thermal shock, vibration, acceleration, mechanical shock, and HTOL. The CMA-545+ operates on a single 3V supply and is internally matched to 50Ω, with no external matching components required.

Key Features

Feature	Advantages
Ultra Low Noise: 0.8 dB NF at 1GHz	Industry Leading Noise Figure, measured in a 50 Ohm environment – without any external matching.
High IP3: +35 dBm IP3 at 1GHz	Combining Low Noise and High IP3 makes this MMIC amplifier ideal for Low Noise Receiver Front End (RFE) because it gives the user advantages at both ends of the dynamic range, sensitivity & high level operation.
Output Power: +20 dBm at 1GHz	The CMA-545+ maintains consistent output power capability over the full operating temperature range making it ideal to be used in remote applications such as LNB's as the L Band driver stage.
Broad Band: 0.05 to 6.0GHz	Broadband covering primary wireless communications bands: Cellular, PCS, LTE, WiMAX.
Internally Matched	No external matching elements required to achieve the advertized noise and output power over the full band.
Ceramic Hermetic Package	Low Inductance, repeatable performance, excellent reliability.
Max Input Power +20 dBm	Ruggedized design operates up to input powers often seen at Receiver inputs. Can operate up to +20 dBm input without the need of an external limiter.
High Reliability	Small signal operating current of 80 mA nominal maintains junction temperatures typically below 130°C at 105°C package terminals.

Notes

- A. Performance and quality attributes and conditions not expressly stated in this specification document are intended to be excluded and do not form a part of this specification document.
B. Electrical specifications and performance data contained in this specification document are based on Mini-Circuit's applicable established test performance criteria and measurement instructions.
C. The parts covered by this specification document are subject to Mini-Circuits standard limited warranty and terms and conditions (collectively, "Standard Terms"); Purchasers of this part are entitled to the rights and benefits contained therein. For a full statement of the Standard Terms and the exclusive rights and remedies thereunder, please visit Mini-Circuits' website at www.minicircuits.com/MCLStore/terms.jsp



Low Noise, High IP3

Monolithic Amplifier

0.05-6 GHz

Product Features

- Ultra Low Noise Figure, 0.8 dB typ. at 1GHz
- High IP3, 35 dBm typ. 1GHz
- Gain, 20dB typ. at 1 GHz
- Output Power, up to +20dBm typ.
- Single Positive Supply Voltage, 3V
- Small size - 3mm x 3mm x 1.14mm
- Ceramic, hermetic, Nitrogen filled



CMA-545+

CASE STYLE: DL1721
PRICE: \$4.95 ea. QTY. (20)

Typical Applications

- Cellular
- ISM
- GSM
- WCDMA
- LTE
- WiMAX
- WLAN

+RoHS Compliant

The +Suffix identifies RoHS Compliance. See our web site for RoHS Compliance methodologies and qualifications

General Description

CMA-545+ is a high dynamic range, low noise, high IP3, high output power, monolithic amplifier. Manufactured using E-PHEMT* technology enables it to work with a single positive supply voltage. Unconditionally stable over the operating frequency. Terminal finish is Ni-pd-Au and it has repeatable performance from lot to lot due to fully automated, tightly controlled semiconductor and assembly processes.

simplified schematic and pad description

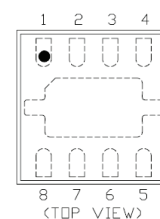
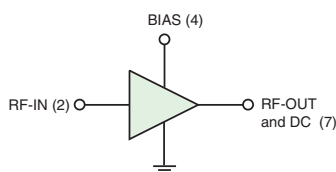

Function	Pad Number	Description (See Application Circuit, Fig. 2)
RF-IN	2	RF input pad
RF-OUT & DC	7	RF output pad (connected to RF-OUT via blocking external cap C2, and Supply voltage Vs via RF Choke L1)
BIAS	4	Bias pad (connected to Vs via Rbias)
GND	1,3,5,6,8, Bottom Center Paddle	Connected to ground

*Enhancement mode Pseudomorphic High Electron Mobility Transistor.

Notes

- A. Performance and quality attributes and conditions not expressly stated in this specification document are intended to be excluded and do not form a part of this specification document.
B. Electrical specifications and performance data contained in this specification document are based on Mini-Circuit's applicable established test performance criteria and measurement instructions.
C. The parts covered by this specification document are subject to Mini-Circuits standard limited warranty and terms and conditions (collectively, "Standard Terms"); Purchasers of this part are entitled to the rights and benefits contained therein. For a full statement of the Standard Terms and the exclusive rights and remedies thereunder, please visit Mini-Circuits' website at www.minicircuits.com/MCLStore/terms.jsp

REV. A
M139193
CMA-545+
DJ/BT/CP
130917
Page 2



Electrical Specifications⁽¹⁾ at 25°C, Z_o=50Ω, (refer to characterization circuit)

Parameter	Condition (GHz)	Min.	Typ.	Max.	Units
Frequency Range		0.05		6.0	GHz
Noise Figure	0.05		1.3	1.4	dB
	0.5		0.8		
	1.0		0.8		
	2.0		1.2		
	3.0		1.3		
	4.0		1.7		
	5.0		2.0		
Gain	0.05	12.7	26.2	15.6	dB
	0.5		23.4		
	1.0		19.7		
	2.0		14.8		
	3.0		12.0		
	4.0		9.7		
	5.0		8.4		
Input Return Loss	0.05-0.5		9.0		dB
	0.5-6		7.0		
Output Return Loss	0.05		13.0		dB
	0.1-3		14.0		
	3-6		12.0		
Output IP3	0.05		32.0		dBm
	0.5		34.0		
	1.0		35.0		
	2.0		37.1		
	3.0		38.0		
	4.0		37.8		
	5.0		38.4		
6.0		36.6			
Output Power @ 1 dB compression ⁽²⁾	0.05	18.3	19.9		dBm
	0.5		19.2		
	1.0		19.0		
	2.0		20.0		
	3.0		20.3		
	4.0		20.3		
	5.0		21.5		
6.0	21.0				
DC Voltage (V _d)		2.8	3.0	3.2	V
DC Current (I _d) ⁽²⁾		65	80	98	mA
DC Current (I _{Rbias})			5.6		mA
DC Current Variation vs. Temperature ⁽³⁾			-0.121		mA/°C
Thermal Resistance			116		°C/W

Absolute Maximum Ratings⁽⁴⁾

Parameter	Ratings
Operating Temperature ⁽⁵⁾	-55°C to 105°C
Storage Temperature	-55°C to 125°C
Channel Temperature	150°C
DC Voltage (Pad 6)	5V
Power Dissipation	500mW
DC Current (Pad 6)	160mA
Bias Current (Pad 7)	10mA
Input Power	20dBm

⁽¹⁾ Measured on Mini-Circuits Characterization test board TB-631+. See Characterization Test Circuit (Fig. 1)

⁽²⁾ Current increases at P1dB

⁽³⁾ (Current at 85°C - Current at -45°C)/130

⁽⁴⁾ Permanent damage may occur if any of these limits are exceeded. These maximum ratings are not intended for continuous normal operation.

⁽⁵⁾ Defined with reference to ground pad temperature.

Notes

- A. Performance and quality attributes and conditions not expressly stated in this specification document are intended to be excluded and do not form a part of this specification document.
- B. Electrical specifications and performance data contained in this specification document are based on Mini-Circuit's applicable established test performance criteria and measurement instructions.
- C. The parts covered by this specification document are subject to Mini-Circuits standard limited warranty and terms and conditions (collectively, "Standard Terms"); Purchasers of this part are entitled to the rights and benefits contained therein. For a full statement of the Standard Terms and the exclusive rights and remedies thereunder, please visit Mini-Circuits' website at www.minicircuits.com/MCLStore/terms.jsp



Characterization Test Circuit

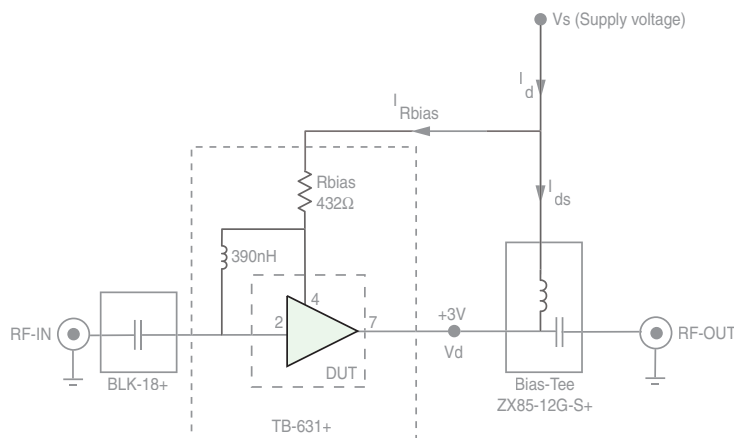

Fig 1. Block Diagram of Test Circuit used for characterization. (DUT soldered on Mini-Circuits Characterization Test Board TB-631+) Gain, Output power at 1dB compression (P1dB), Output IP3 (OIP3) are measured using R&S Network Analyzer ZVA-24. Noise Figure measured using Agilent's N5242A PNA-X microwave network analyzer.

Conditions:

1. Gain: Pin=-25 dBm
2. Output IP3 (OIP3): Two tones, spaced 1 MHz apart, 0 dBm/tone at output.
3. Vs adjusted for 3V at device (Vd), compensating loss of bias tee.

Recommended Application Circuit

(refer to evaluation board for PCB Layout and component values)

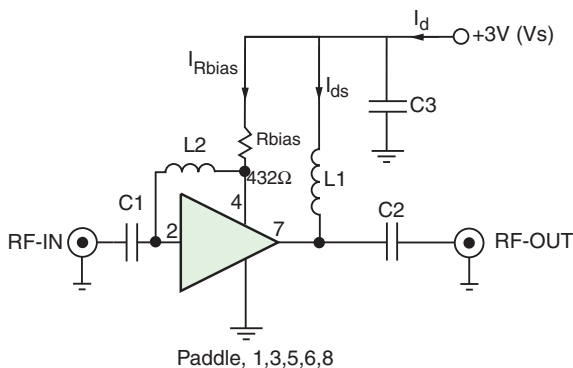
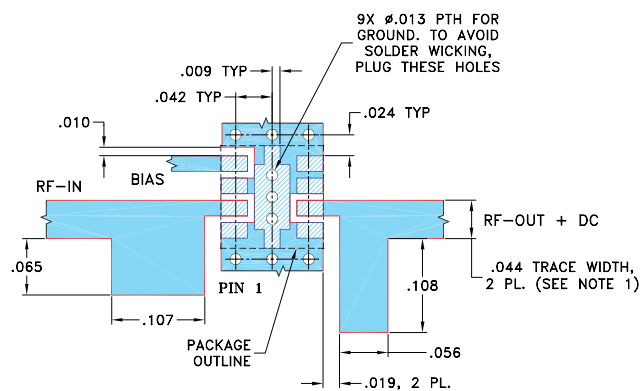

Fig 2. Recommended Application Circuit
Note: Resistance of L1, 0.1-0.2Ω typically. For component values, please see evaluation board drawing.

Suggested PCB Layout (PL-365)



NOTES:

1. TRACE WIDTH IS SHOWN FOR ROGERS RO4350B WITH DIELECTRIC THICKNESS .020" ± .0015"; COPPER: 1/2 OZ. EACH SIDE. FOR OTHER MATERIALS TRACE WIDTH AND GAP MAY NEED TO BE MODIFIED.
2. BOTTOM SIDE OF THE PCB IS CONTINUOUS GROUND PLANE.

- DENOTES PCB COPPER LAYOUT WITH SMOBC (SOLDER MASK OVER BARE COPPER)
- DENOTES COPPER LAND PATTERN FREE OF SOLDER MASK

Product Marking

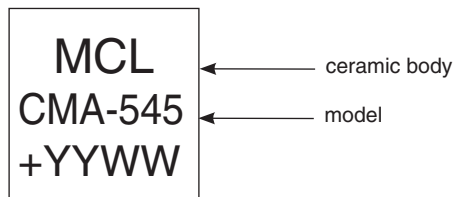

Notes

- A. Performance and quality attributes and conditions not expressly stated in this specification document are intended to be excluded and do not form a part of this specification document.
- B. Electrical specifications and performance data contained in this specification document are based on Mini-Circuit's applicable established test performance criteria and measurement instructions.
- C. The parts covered by this specification document are subject to Mini-Circuits standard limited warranty and terms and conditions (collectively, "Standard Terms"); Purchasers of this part are entitled to the rights and benefits contained therein. For a full statement of the Standard Terms and the exclusive rights and remedies thereunder, please visit Mini-Circuits' website at www.minicircuits.com/MCLStore/terms.jsp



Additional Detailed Technical Information	
<i>additional information is available on our dash board. To access this information click here</i>	
Performance Data	Data Table
	Swept Graphs
	S-Parameter (S2P Files) Data Set (.zip file)
Case Style	DL1721 <i>Ceramic package, exposed paddle, Terminal finish: Ni,Pd,Au</i>
Tape & Reel Standard quantities available on reel	F66 <i>7" reels with 10, 20, 50, 100, 200, 500 or 1K devices.</i>
Suggested Layout for PCB Design	PL-365
Evaluation Board	TB-631+
Environmental Ratings	ENV-68

ESD Rating

Human Body Model (HBM): Class 1A (250V to <500V) in accordance with ANSI/ESD STM 5.1 - 2001

Machine Model (MM): Class M1 (<100V) in accordance with ANSI/ESD STM5.2-1999; passes 40V

MSL Rating

Moisture Sensitivity: MSL1 (these parts are hermetic, air cavity and therefore, MSL ratings do not strictly apply. For handling purpose, use MSL1)

Qualification Testing

Test Description		Test Method/Process	Results
1	Hermeticity (fine and gross leak)	MIL-STD-202 Method 112, Cond. C & D	Pass
2	Acceleration, 30Kg, Y1 Direction	MIL-STD-883 Method 2001 Cond. E	Pass
3	Vibration , 10-2000Hz sine, 20g, 3 axis	MIL-STD-202 Method 204, Cond. D	Pass
4	Mechanical shock	MIL-STD-202 Method 213, Cond . A	Pass
5	PIND 20G's @ 130 Hz	MIL-STD-750 Method 2052.2	Pass
6	Temp Cycle -55C/+125C, 1000 Cycles	MIL-STD-202 Method 107	Pass
7	Autoclave, 121C, RH 100%, 15 Psig, 96 hrs	JESD22-A102C	Pass
8	HTOL, 1000hrs, 105C at rated Voltage condition	MIL-STD-202 Method 108, Cond . D	Pass
9	Bend Test	JESD22-B113	Pass
10	Resistance to soldering heat, 3x reflow, 260C peak	JESD22-B102	Pass
11	Drop Test	JESD22-B111	Pass
12	Adhesion Strength	Push Test>10 lb	Pass

Notes

- A. Performance and quality attributes and conditions not expressly stated in this specification document are intended to be excluded and do not form a part of this specification document.
- B. Electrical specifications and performance data contained in this specification document are based on Mini-Circuit's applicable established test performance criteria and measurement instructions.
- C. The parts covered by this specification document are subject to Mini-Circuits standard limited warranty and terms and conditions (collectively, "Standard Terms"); Purchasers of this part are entitled to the rights and benefits contained therein. For a full statement of the Standard Terms and the exclusive rights and remedies thereunder, please visit Mini-Circuits' website at www.minicircuits.com/MCLStore/terms.jsp

