

Wideband, Microwave, 0.5W

Monolithic Amplifier

AVM-273HP+

50Ω 13 to 26.5GHz

The Big Deal

- Wideband 13 to 26.5 GHz
- Output power up to +27dBm
- Excellent directivity, 43 dB typ. @ 20 GHz
- Unconditionally stable
- Excellent gain flatness, ±1 dB



CASE STYLE: DG1677-1

Product Overview

Mini-Circuits AVM-273HP+ is a three stage balanced, wideband monolithic amplifier delivering up to 0.5W power and operating over 13 to 26.5 GHz. It is designed using PHEMT technology and is unconditionally stable. Its outstanding isolation enables it to be used as a wideband isolation amplifier or buffer amplifier in a variety of microwave systems including point to point radios, military EW and radar, DBS, and VSAT.

Key Features

Feature	Advantages
Wideband	Wide frequency coverage up to 26.5 GHz supports many microwave applications.
Pout up to +27 dBm	Can be used as a low-cost driver for high power amplifiers.
Excellent active directivity, 43 dB @ 20 GHz (directivity = isolation – gain)	Can be used as an inter-stage isolation amplifier, minimizing interaction of adjacent components.
Unconditionally stable	Eliminates the need for any compensating network to prevent unintended oscillation.
Small package	Small size for high power with low inductance, repeatable transitions, and excellent thermal contact to PCB.



Wideband, Microwave, 0.5W

Monolithic Amplifier

13-26.5 GHz

Product Features

- Gain, 13 dB typ.
- Output Power, up to +27 dBm typ.
- Excellent directivity, 43 dB typ. at 20 GHz
- Unconditionally Stable
- Aqueous washable; 5 mm x 5 mm SMT package

Typical Applications

- Point to Point Radio
- Military EW and Radar
- DBS
- VSAT
- Wideband Isolation amplifier



CASE STYLE: DG1677-1
PRICE: \$27.95 ea. QTY. (10)

AVM-273HP+

+RoHS Compliant

The +Suffix identifies RoHS Compliance. See our web site for RoHS Compliance methodologies and qualifications

General Description

The AVM-273HP+ is a three stage balanced wideband monolithic amplifier delivering up to 0.5W power operating over 13 to 26.5 GHz. It is manufactured using PHEMT technology and is unconditionally stable. Its outstanding isolation enables it to be used as a wideband isolation amplifier or buffer amplifier in a variety of microwave systems.

Simplified Schematic

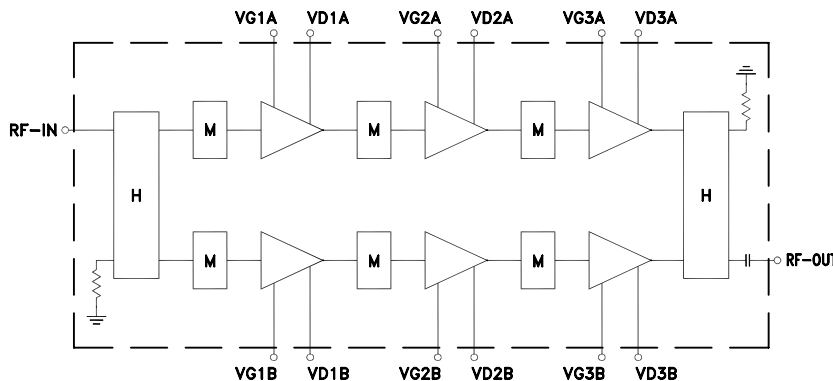

Notes:
H - 90° Hybrid
M - Matching Network



Electrical Specifications ⁽¹⁾ at 25°C, Zo=50Ω, (refer to characterization circuit, Fig.1)

Parameter	Condition (GHz)	Min.	Typ.	Max.	Units.
Frequency Range		13.0		26.5	GHz
DC Voltage (VD1 to VD3 (A)&(B)) ⚠			5.0		V
DC Voltage (VG1 to VG3 (A)&(B)) ⚠			-0.8		V
DC Current (ID1+ID2+ID3; (A)&(B))			559	590	mA
DC Current (IG1+IG2+IG3; (A)&(B))			0.5		mA
Gain	13.0	12.0	12.8		dB
	14.0		12.8		
	15.0		13.0		
	16.0		13.6		
	17.0		14.2		
	18.0		15.1		
	20.0		14.7		
	24.0		13.8		
Input Return Loss	13.0		16.9		dB
	14.0		17.1		
	15.0		17.6		
	16.0		17.0		
	17.0		19.4		
	18.0		15.5		
	20.0		8.9		
	24.0		9.0		
Output Return Loss	13.0		8.1		dB
	14.0		12.7		
	15.0		18.9		
	16.0		19.3		
	17.0		16.6		
	18.0		13.2		
	20.0		8.0		
	24.0		10.6		
Directivity (Isolation- Gain)	13.0		43		dB
	14.0				
	15.0				
	16.0				
	17.0				
	18.0				
	20.0				
	24.0				
Output Power @ 1 dB compression	13.0		22.6		dBm
	14.0		24.3		
	15.0		25.6		
	16.0		26.3		
	17.0		26.4		
	18.0		26.9		
	20.0		26.6		
	24.0		26.5		
OIP3	13.0		28.7		dBm
	14.0		30.6		
	15.0		32.2		
	16.0		32.4		
	17.0		33.2		
	18.0		32.1		
	20.0		31.0		
	24.0		29.7		
Noise Figure	13.0		9.8		dB
	14.0		9.6		
	15.0		9.3		
	16.0		8.9		
	17.0		8.8		
	18.0		8.4		
	20.0		8.5		
	24.0		7.5		
DC Current Variation vs. Temperature (2)			0.32		mA/°C
			0.145		mA/mV
Thermal Resistance			16.3		°C/W

Absolute Maximum Ratings⁽³⁾

Operating Temperature ⁽⁴⁾	-40°C to 85°C
Storage Temperature	-65°C to 150°C
Channel Temperature	136°C
DC Voltage-Drain (Pads 11,13,15,26,28,30) @ VG=-0.8V ⁽⁵⁾	+6 V
DC Voltage-Gate (Pads 10,12,14,27,29,31) @ VD=+5V ⁽⁶⁾	-6 V
Power Dissipation	3.1 W
DC Current (Pads 11,13,15,26,28,30)	620 mA
Input Power (CW)	16 dBm
DC Voltage on pins 19 & 20 (@VD=5V & VG=-0.8V)	+10V



NOTE: to prevent damage to the AVM-273HP+, and to ensure proper operation, all bias voltages must be applied in the following sequence for both Power On and for Power Off:

Power ON

1. Connect all Vg wires together (to ensure all stages are biased simultaneously).
2. Connect all Vd wires together (to ensure all stages are biased simultaneously).
3. Set Vg to -2V
4. Set Vd to +5V
5. Adjust Vg until the desired I_{dd} is reached (the typical Vg is around -0.8V).
6. Apply RF signal.

Power OFF

1. Turn OFF RF signal
2. Set Vg to -2.0V
3. Turn OFF Vd (Vd to 0V)
4. Turn OFF Vg (Vg to 0V)

Notes:

1. Measured on Mini-Circuits Test Board TB-715-5V. See Characterization Test Circuit (Fig. 1). See cautionary note .
2. (Current at 85°C - Current at -45°C)/130
3. Permanent damage may occur if any of these limits are exceeded. These maximum ratings are not intended for continuous normal operation.
4. Defined with reference to ground pad temperature.
5. VG=VG1, VG2, VG3 (A&B)
6. VD= VD1, VD2, VD3 (A&B)

ALTERNATELY – utilize the bias circuit defined in Figure 1 which does not require any voltage sequencing or gate voltage adjustment. This circuit operates with +6.4 Volts and -5 Volts and automatically ensures proper sequencing of supply voltages for safe operation. MINI-CIRCUITS WARRANTY IS VOID IF USED WITHOUT CIRCUIT DEFINED IN FIGURE 1

Simplified Schematic and Pad Description

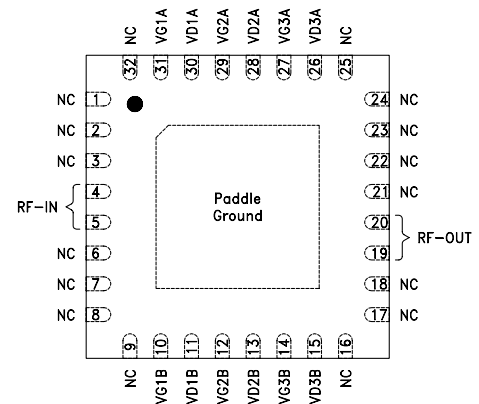
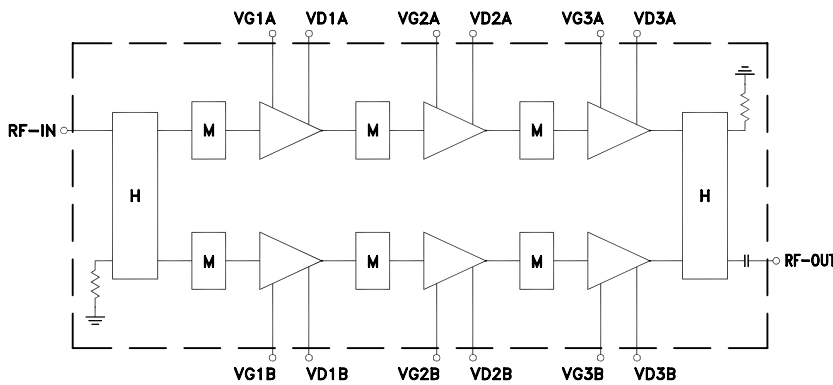

Notes:

- H - 90° Hybrid
- M - Matching Network

Function	Pad Number	Description (See Application Circuit)
RF-In	4,5	RF Input
RF-Out	19,20	RF-Output (DC blocked)
VG1 A	31	Gate Voltage of first stage amplifier (Top)
VG2 A	29	Gate Voltage of second stage amplifier (Top)
VG3 A	27	Gate Voltage of third stage amplifier (Top)
VD1 A	30	Drain Voltage of first stage amplifier (Top)
VD2 A	28	Drain Voltage of second stage amplifier (Top)
VD3 A	26	Drain Voltage of third stage amplifier (Top)

Function	Pad Number	Description (See Application Circuit)
VG1 B	10	Gate Voltage of first stage amplifier (Bottom)
VG2 B	12	Gate Voltage of second stage amplifier (Bottom)
VG3 B	14	Gate Voltage of third stage amplifier (Bottom)
VD1 B	11	Drain Voltage of first stage amplifier (Bottom)
VD2 B	13	Drain Voltage of second stage amplifier (Bottom)
VD3 B	15	Drain Voltage of third stage amplifier (Bottom)
NC	1-3, 6-9, 16-18, 21-25, 32	No Connection, not used internally



Characterization Test Circuit

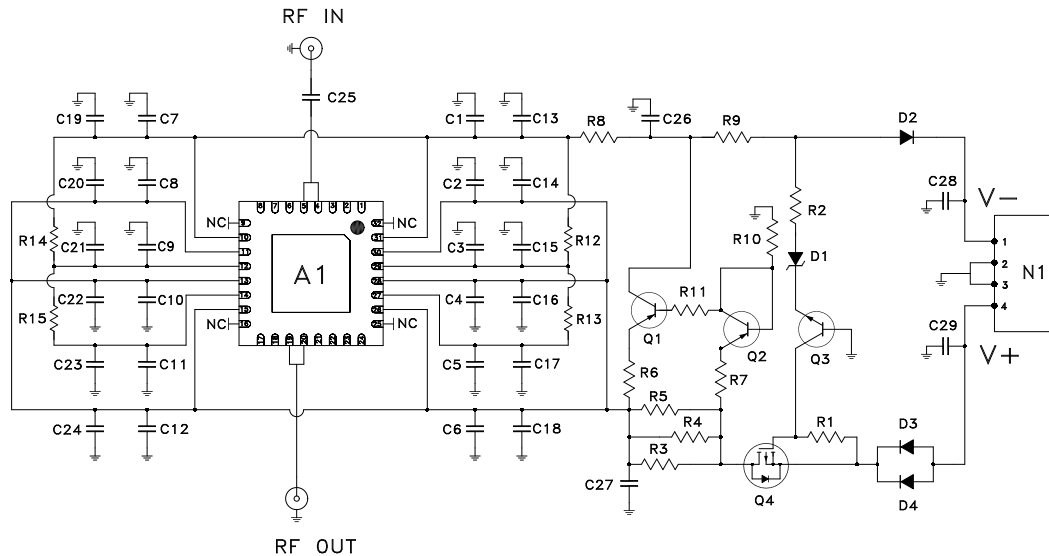

Fig. 1 Schematic of Test Board TB-715-5V (Test & Application)

TB-715-5V incorporates Current Biasing, automatic voltage sequencing, reverse voltage protection circuitry.

Test board used for characterization. (DUT soldered on Mini-Circuits Characterization Test Board TB-715-5V) Gain, Output power at 1dB compression (P1dB), Noise Figure, Output IP3 (OIP3) are measured using Agilent's N5242A PNA-X microwave network analyzer.

Conditions:

1. Gain: Pin=-25 dBm
2. Output IP3 (OIP3): Two tones, spaced 1 MHz apart, 0 dBm/tone at output.
3. V+ set to +6.4V to account for 1.4V drop in bias circuit resulting in +5V at drain (VD1 to VD3 (A&B))
4. V- is set to -5V to realize proper gate voltage (-0.8V typ.)

NOTE: MINI-CIRCUITS WARRANTY IS VOID IF FIGURE 1 IS NOT USED.

BOM of Test Board TB-715-5V

SEQ	Manufacturer P/N	Description	Manufacturer
A1	DUT AVM-273HP+	PHEMT Amplifier	Mini-Circuits
Q1,Q2	MMBT3906	PNP Transistor	Fairchild Semiconductor
Q3	MMBT3904	NPN Transistor	Fairchild Semiconductor
Q4	NTS4101PT1G	P-Channel MOSFET	ON Semiconductor
D1	MMSZ5228BT1G	Zener Diode	ON Semiconductor
D2-D4	MBR0520LT1G	Schottky Diode	ON Semiconductor
C1,C6,C7,C12-C24	GRM155R71C104KA88D	0402 Capacitors 0.1µF	Murata Electronics
C2-C5,C8-C11	GRM033R71E471KA01B	0201 Capacitor, 470 pF	Murata Electronics
C25	ATC550L104KTT	0402 Capacitors 0.1µF	American Technical Ceramics
C26,C27	GRM1555C1H101GA01D	0402 Capacitor, 100 pF, 2%	Murata Electronics
C28,C29	GRM188R71C105KA12D	0603 Capacitor, 1µF	Murata Electronics
R1,R2,R9,R10	RK73H1JTTD1002F	0603 Resistor, 10kΩ	KOA Speer
R3-R5	RK73H2BTDD3R32F	1206 Resistor, 3.32 Ω	KOA Speer
R6	RK73H1JTTD1000F	0603 Resistor, 100 Ω	KOA Speer
R7	RK73H1JTTD1501F	0603 Resistor, 1.5 kΩ	KOA Speer
R8	RK73H1JTTD1001F	0603 Resistor, 1.0 kΩ	KOA Speer
R11	RK73Z2BTDD	1206 Resistor, 0 Ω	KOA Speer
R12-R15	RK73Z2ATDD	0805, 0Ω	KOA Speer
N	53398-0471	4-Pin Header	Molex-Waldom

Product Marking



Additional Detailed Technical Information	
<i>additional information is available on our dash board. To access this information click here</i>	
Performance Data	Data Table
	Swept Graphs
	S-Parameter (S2P Files) Data Set (.zip file)
Case Style	DG1677-1 (SOT 89) <i>Plastic package, exposed paddle, lead finish: tin-silver over nickel</i>
Tape & Reel	F68
Standard quantities available on reel	<i>7" reels with 10, 20, 50, 100, 200, 500 or 1K devices</i>
Suggested Layout for PCB Design	PL-401
Evaluation Board	TB-715-5V

ESD Rating

Human Body Model (HBM): Class 1A in accordance with JESD22-A114F

Machine Model (MM): Class A (pass 25V) in accordance JESD22-A115

MSL Rating

Moisture Sensitivity: MSL1 in accordance with IPC/JEDEC J-STD-020D

MSL Test Flow Chart

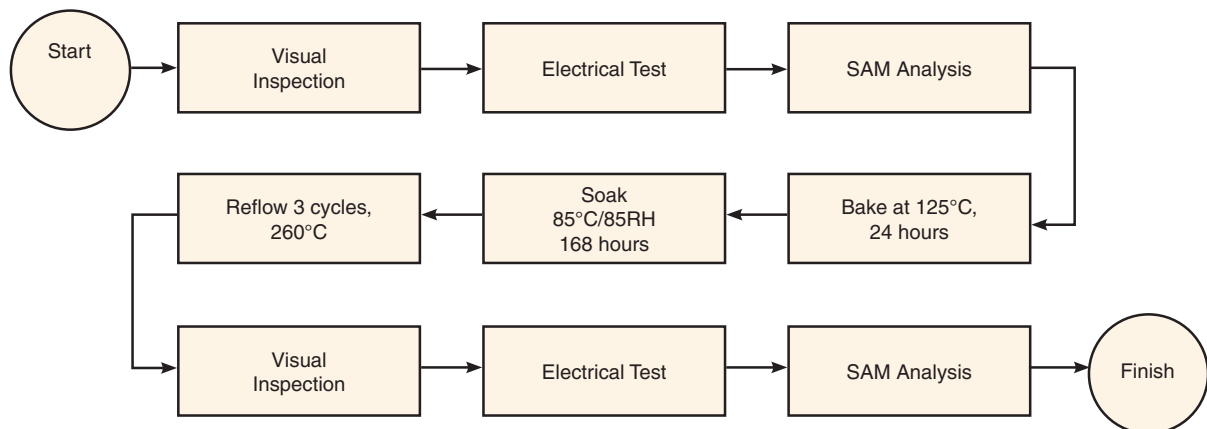

Additional Notes

- Performance and quality attributes and conditions not expressly stated in this specification document are intended to be excluded and do not form a part of this specification document.
- Electrical specifications and performance data contained in this specification document are based on Mini-Circuit's applicable established test performance criteria and measurement instructions.
- The parts covered by this specification document are subject to Mini-Circuits standard limited warranty and terms and conditions (collectively, "Standard Terms"); Purchasers of this part are entitled to the rights and benefits contained therein. For a full statement of the Standard Terms and the exclusive rights and remedies thereunder, please visit Mini-Circuits' website at www.minicircuits.com/MCLStore/terms.jsp