

Wideband Microwave Amplifier

AVA-183+

50Ω

6 to 18 GHz

The Big Deal

- Surface Mount Amplifier up to 18 GHz
- Integrated matching, DC Blocks and bias circuits
- High Reverse Isolation



CASE STYLE: DQ849

Product Overview

The Mini-Circuits AVA-183+ is a surface mount, microwave amplifier and fully integrated gain block up to 18 GHz. It is packaged in Mini-Circuits industry standard 3x3 mm MCLP (QFN) package, which provides excellent RF and thermal performance. The AVA-183+ integrates the entire matching network with the majority of the bias circuit inside the package, reducing the need for complicated external circuits. This approach makes the AVA-183+ extremely flexible and enables simple, straightforward use.

Key Features

Feature	Advantages
Wideband, 6 to 18 GHz	Broad frequency range supports a wide array of applications from microwave radio and radar , to military communications and countermeasures.
Excellent Gain Flatness	Typical ± 0.6 dB gain flatness across the entire frequency range minimizes the need for external equalizer networks making it a great fit for instrumentation and EW applications.
High Isolation	With reverse isolation of 38 dB (25 dB directivity), the AVA-183+ is an excellent choice for buffering broadband circuits. It is an ideal LO driver amplifier and provides designers system flexibility and margin when integrating cascaded RF components.
Manufacturability	MSL1 and ESD Class1A (HBM) ratings minimize special handling on production lines.



P.O. Box 350166, Brooklyn, New York 11235-0003 (718) 934-4500 Fax (718) 332-4661 *The Design Engineers Search Engine* Provides ACTUAL Data Instantly at minicircuits.com

IF/RF MICROWAVE COMPONENTS

Notes: 1. Performance and quality attributes and conditions not expressly stated in this specification sheet are intended to be excluded and do not form a part of this specification sheet. 2. Electrical specifications and performance data contained herein are based on Mini-Circuit's applicable established test performance criteria and measurement instructions. 3. The parts covered by this specification sheet are subject to Mini-Circuits standard limited warranty and terms and conditions (collectively, "Standard Terms"); Purchasers of this part are entitled to the rights and benefits contained therein. For a full statement of the Standard Terms and the exclusive rights and remedies thereunder, please visit Mini-Circuits' website at www.minicircuits.com/MCLStore/terms.jsp.

Wideband, Microwave

Monolithic Amplifier

6-18 GHz

Product Features

- Gain, 12.3 dB typ. & Flatness, ± 0.6 dB
- Output Power, up to +18.4 dBm typ.
- Excellent isolation, 38 dB typ.
- Single Positive Supply Voltage, 5V
- Integrated DC blocks, Bias-Tee & Microwave bypass capacitor
- Unconditionally Stable
- Aqueous washable; 3mm x 3mm SMT package



AVA-183+

CASE STYLE: DQ849
 PRICE: \$17.95 ea. QTY. (1-9)

+ RoHS compliant in accordance with EU Directive (2002/95/EC)

The +Suffix has been added in order to identify RoHS Compliance. See our web site for RoHS Compliance methodologies and qualifications.

Typical Applications

- Military EW and Radar
- DBS
- Wideband Isolation amplifier
- Microwave point-to-point radios
- Satellite systems

General Description

AVA-183+ is a wideband medium power monolithic amplifier with outstanding gain flatness up to 18 GHz. It is manufactured using PHEMT* technology and is unconditionally stable. Its outstanding isolation enables it to be used as a wideband isolation amplifier or buffer amplifier in a variety of microwave systems.

simplified schematic and pad description

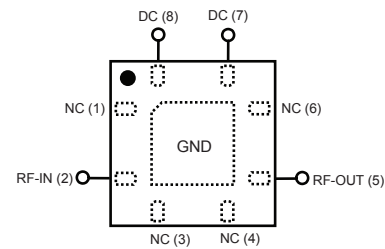
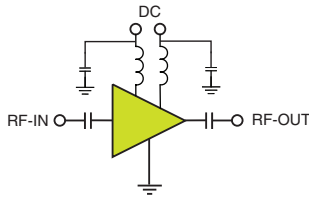

Function	Pad Number	Description (See Application Circuit, Fig. 2)
RF-IN	2	RF input pad
RF-OUT	5	RF output pad
DC	7(V_{D1}), 8 (V_{D2})	DC power supply (short pins 7&8 externally)
GND	paddle in center of bottom	Connected to ground
NOT USED	1,3,4,6	No internal connection; recommended use: per PCB Layout PL-328

*Pseudomorphic High Electron Mobility Transistor.



For detailed performance specs & shopping online see web site

P.O. Box 350166, Brooklyn, New York 11235-0003 (718) 934-4500 Fax (718) 332-4661 *The Design Engineers Search Engine* Provides ACTUAL Data Instantly at minicircuits.com

Notes: 1. Performance and quality attributes and conditions not expressly stated in this specification sheet are intended to be excluded and do not form a part of this specification sheet. 2. Electrical specifications and performance data contained herein are based on Mini-Circuit's applicable established test performance criteria and measurement instructions. 3. The parts covered by this specification sheet are subject to Mini-Circuits standard limited warranty and terms and conditions (collectively, "Standard Terms"); Purchasers of this part are entitled to the rights and benefits contained therein. For a full statement of the Standard Terms and the exclusive rights and remedies thereunder, please visit Mini-Circuits' website at www.minicircuits.com/MCLStore/terms.jsp.

REV. OR
 M126227
 AVA-183+
 ED-13817
 MCL NY
 100129
 Page 2

Electrical Specifications⁽¹⁾ at 25°C, Z₀=50Ω, (refer to characterization circuit, Fig.1)

Parameter	Condition (GHz)	Min.	Typ.	Max.	Units
Frequency Range		6.0		18.0	GHz
DC Voltage (V _{D1} , V _{D2})			5.0		V
DC Current (I _{D1} +I _{D2})			134	145	mA
Gain	6.0		12.5		dB
	8.0	10.0	12.7		
	10.0	10.0	12.4		
	12.0		12.0		
	14.0		11.7		
	16.0		12.6		
Input Return Loss	6.0		15.6		dB
	8.0		25.7		
	10.0		17.9		
	12.0		12.4		
	14.0		11.3		
	16.0		15.8		
Output Return Loss	6.0		21.0		dB
	8.0		25.0		
	10.0		18.6		
	12.0		14.3		
	14.0		13.6		
	16.0		20.3		
Output IP3	6.0		27.1		dBm
	8.0		26.3		
	10.0		26.5		
	12.0		26.3		
	14.0		26.0		
	16.0		25.4		
Output Power @ 1 dB compression	6.0		18.9		dBm
	8.0		18.7		
	10.0	16.0	18.6		
	12.0		18.7		
	14.0		18.5		
	16.0		18.0		
Noise Figure	6.0		7.0		dB
	8.0		6.3		
	10.0		5.6		
	12.0		6.5		
	14.0		6.5		
	16.0		6.1		
18.0		6.1			
Directivity (Isolation-Gain)			25.0		dB
DC Current Variation vs. Temperature ⁽²⁾			-0.087		mA/°C
Thermal Resistance			47		°C/W

Absolute Maximum Ratings⁽³⁾

Parameter	Ratings
Operating Temperature ⁽⁴⁾	-40°C to 85°C
Storage Temperature	-55°C to 100°C
Channel Temperature	160°C
DC Voltage (Pad 7,8)	5.5V
Voltage (Pads 2, 5)	10V
Power Dissipation	860 mW
DC Current (Pad 7+8)	160mA
Input Power	20

⁽¹⁾ Measured on Mini-Circuits Characterization test fixture TB-547+ See Characterization Test Circuit (Fig. 1)

⁽²⁾ (Current at 85°C - Current at -45°C)/130

⁽³⁾ Permanent damage may occur if any of these limits are exceeded.

These maximum ratings are not intended for continuous normal operation.

⁽⁴⁾ Defined with reference to ground pad temperature.

Mini-Circuits
ISO 9001 ISO 14001 AS 9100 CERTIFIED

P.O. Box 350166, Brooklyn, New York 11235-0003 (718) 934-4500 Fax (718) 332-4661 The Design Engineers Search Engine Provides ACTUAL Data Instantly at minicircuits.com

IFIRF MICROWAVE COMPONENTS

For detailed performance specs & shopping online see web site

Notes: 1. Performance and quality attributes and conditions not expressly stated in this specification sheet are intended to be excluded and do not form a part of this specification sheet. 2. Electrical specifications and performance data contained herein are based on Mini-Circuit's applicable established test performance criteria and measurement instructions. 3. The parts covered by this specification sheet are subject to Mini-Circuits standard limited warranty and terms and conditions (collectively, "Standard Terms"); Purchasers of this part are entitled to the rights and benefits contained therein. For a full statement of the Standard Terms and the exclusive rights and remedies thereunder, please visit Mini-Circuits' website at www.minicircuits.com/MCLStore/terms.jsp.

Characterization Test Circuit

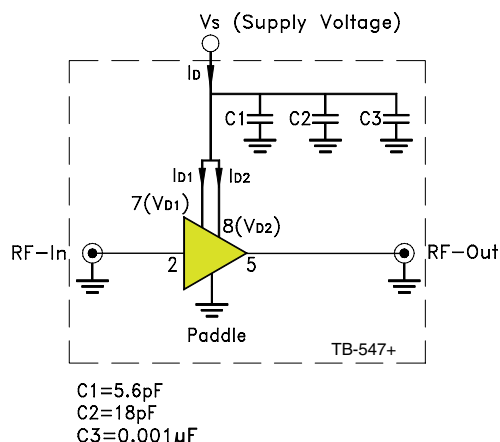

Recommended Application Circuit

(refer to evaluation board for PCB Layout and component values)

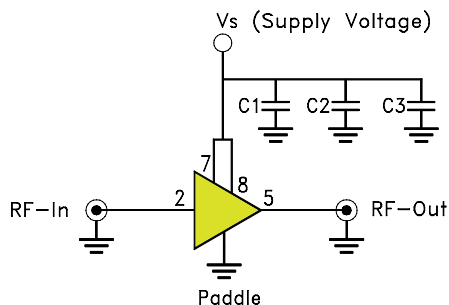

Fig 2. Recommended Application Circuit

Fig 1. Block Diagram of Test Circuit used for characterization. (DUT soldered on Mini-Circuits Characterization Test Board TB-547+) Gain, Output power at 1dB compression (P1dB), Noise Figure, Output IP3 (OIP3) are measured using Agilent's N5242A PNA-X microwave network analyzer.

Conditions:

1. Gain: Pin=-25 dBm
2. Output IP3 (OIP3): Two tones, spaced 1 MHz apart, -10 dBm/tone at output.
3. Vs adjusted for 5V at device (V_{D1} and V_{D2}), compensating loss of bias lines.

Outline Drawing

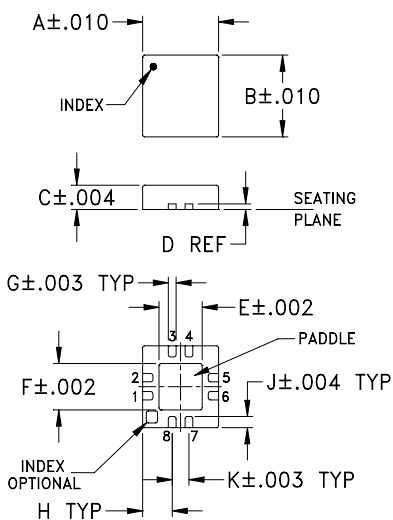

PCB Land Pattern

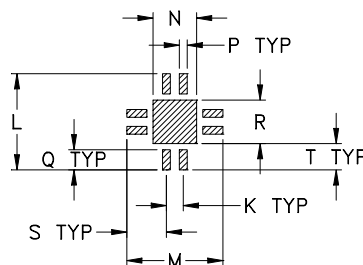

Suggested Layout,
Tolerance to be within ±0.02

Outline Dimensions (inch / mm)

A	B	C	D	E	F	G	H	J	
.118	.118	.035	.008	.067	.067	.012	.046	.016	
3.00	3.00	0.89	0.20	1.70	1.70	0.30	1.17	0.41	
K	L	M	N	P	Q	R	S	T	wt
.026	.148	.148	.067	.012	.031	.067	.061	.041	grams
0.66	3.76	3.76	1.70	0.30	0.79	1.70	1.55	1.04	0.02



P.O. Box 350166, Brooklyn, New York 11235-0003 (718) 934-4500 Fax (718) 332-4661 The Design Engineers Search Engine Provides ACTUAL Data Instantly at minicircuits.com

IF/RF MICROWAVE COMPONENTS

Notes: 1. Performance and quality attributes and conditions not expressly stated in this specification sheet are intended to be excluded and do not form a part of this specification sheet. 2. Electrical specifications and performance data contained herein are based on Mini-Circuit's applicable established test performance criteria and measurement instructions. 3. The parts covered by this specification sheet are subject to Mini-Circuits standard limited warranty and terms and conditions (collectively, "Standard Terms"); Purchasers of this part are entitled to the rights and benefits contained therein. For a full statement of the Standard Terms and the exclusive rights and remedies thereunder, please visit Mini-Circuits' website at www.minicircuits.com/MCLStore/terms.jsp.

Product Marking

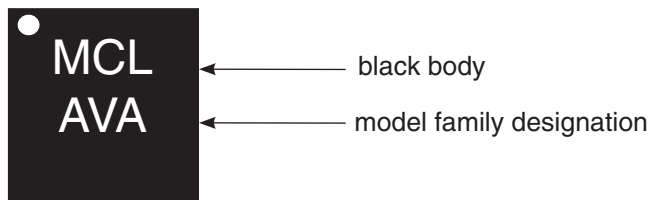

Additional Detailed Technical Information

Additional information is available on our web site www.minicircuits.com. To access this information enter the model number on our web site home page.

Performance data, graphs, s-parameter data set (.zip file)

Case Style: DQ849

Plastic package, exposed paddle, lead finish: tin silver nickel

Tape & Reel: F104

Suggested Layout for PCB Design: PL-328

Evaluation Board: TB-547+

Environmental Ratings: ENV08T1

ESD Rating

Human Body Model (HBM): 1A (250 to <500V) in accordance with ANSI/ESD STM 5.1 - 2001

Machine Model (MM): M1 (passes 25V) in accordance with ANSI/ESD STM5.2-1999

MSL Rating

Moisture Sensitivity: MSL1 in accordance with IPC/JEDEC J-STD-020D

MSL Test Flow Chart

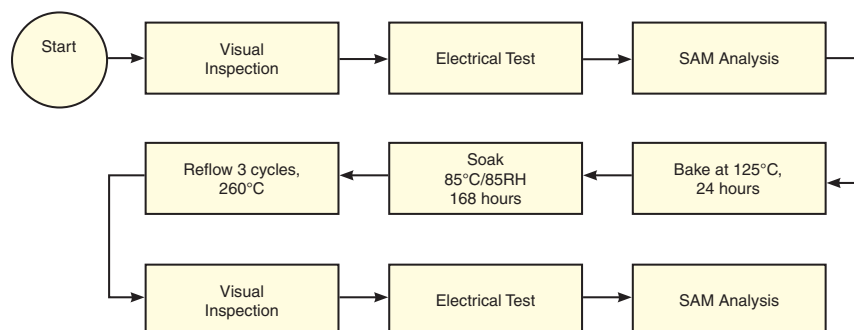

For detailed performance specs & shopping online see web site

P.O. Box 350166, Brooklyn, New York 11235-0003 (718) 934-4500 Fax (718) 332-4661 *The Design Engineers Search Engine* Provides ACTUAL Data Instantly at minicircuits.com

Notes: 1. Performance and quality attributes and conditions not expressly stated in this specification sheet are intended to be excluded and do not form a part of this specification sheet. 2. Electrical specifications and performance data contained herein are based on Mini-Circuit's applicable established test performance criteria and measurement instructions. 3. The parts covered by this specification sheet are subject to Mini-Circuits standard limited warranty and terms and conditions (collectively, "Standard Terms"); Purchasers of this part are entitled to the rights and benefits contained therein. For a full statement of the Standard Terms and the exclusive rights and remedies thereunder, please visit Mini-Circuits' website at www.minicircuits.com/MCLStore/terms.jsp.